



**Nipco<sup>TM</sup>**  
**Technology**  
**Precise Pressure Profiles**

**Guarneri**  **Technology**  
NIPCO<sup>TM</sup> Technology

# Our Family Company's Story

## Four generations of calender engineering

### One name - Endless innovation - Always Guarneri

Over more than 70 years, Guarneri has built a legacy of expertise and innovation, guaranteeing success and continuously advancing the world's most sophisticated calender control technology: Nipco™. Nipco™ Technology so exceptional it has inspired countless imitations.



**1950** Ettore Guarneri founded Officina Meccanica Ettore Guarneri in Busto Arsizio, at the historic site on Via Cà Bianca, which remains active and operational to this day.

**1954** Tullio Guarneri joined his father's company, beginning to supply local textile manufacturers. At the time, Busto Arsizio was known as the "Italian Manchester," due to the concentration of textile companies in the area.

**1983** Ettore Guarneri joined the company, soon followed by his brother Alberto. Together, they expanded the company's commercial and technical network, first across Europe and then worldwide.

**1999** Following a key commercial agreement, the global sales network was strengthened and consolidated even further.

**2002** The Guarneri family signs a world exclusive agreement for the use of Nipco™ rollers with Voith Paper GmbH, creator of Nipco™ technology already famous in the world for paper mills.

**2004** The new headquarters on Via Stefano Ferrario in Busto Arsizio was inaugurated, while the historic site on Via Cà Bianca continued operations.

**2016** Voith Paper Walztechnik AG in Zurich became not only a supplier of Nipco™ technology but also a strategic commercial partner, creating a high-level, long-term partnership.

**2022** On March 16th, Guarneri Technology acquired Voith Paper Walztechnik AG, along with the Nipco™ brand and its patents, becoming a global leader in textile calendering, technical textiles, special applications, and the paper embossing sector.

**Today** The legacy continues with the fourth generation. Stefano and Andrea, children of Ettore and Alberto, have joined the company, carrying forward the Family's tradition of innovation and excellence in calender manufacturing. The corporate motto, "**A Family Company**" reflects the Guarneri Family's full dedication to developing and growing what is considered a shared heritage for all Customers, a legacy built on passion, expertise, and unwavering commitment. A Legacy of Excellence.



**March 16th, 2022**

## **The day Nipco Technology became part of the Guarneri legacy**

This was the moment Guarneri Technology signed the agreement with Voith to acquire Voith Paper Walztechnik AG, the world-renowned, exclusive provider of Nipco™ roll systems and solutions for industrial applications. A strategic move that marks a decisive turning point, strengthening Guarneri Technology's position as a leading global player in the calendering industry. Voith Nipco™ rolls have been integrated into Guarneri calender systems for many years. Not only in textiles and technical textiles but also in the most specialized industrial applications, customers around the world rely on our combined expertise. This strategic step is the natural evolution of a strong and forward-looking partnership, creating real and tangible value for our customers," says Ettore Guarneri, CEO of Guarneri Technology.

With this acquisition, Guarneri Technology consolidates a high-value portfolio of fully optimized and customized solutions for a wide range of Nipco™ roll applications: from finishing textiles and technical fabrics, to producing floor coverings and magazines, from rolling steel and aluminum sheets to processing food products.

Nipco™ roll systems allow precise, independent adjustment of forces in the nip (pressure zone), ensuring complete control and maximum uniformity. Depending on the configuration, parallel nip operation is possible, where the deflection of the Nipco™ roll perfectly matches that of the counter roll, delivering consistent high performance. These rolls are also ideal for nonwoven applications, such as thermal bonding, further expanding their range of potential uses. One of the greatest strengths of the Nipco™ system is its ability to be retrofitted into existing installations without major structural modifications—a competitive advantage that opens virtually limitless application possibilities.

All supported by expert technical services and continuous application support. With over 50 years of Nipco™ technology and more than 7.000 rolls in operation worldwide, Guarneri Technology further strengthens its position across the textile,

wood, printing, and steel industries. This growth is built on passion, engineering excellence, and a relentless commitment to developing robust, reliable, and maintenance-friendly solutions. The goal is clear: to provide customers with concrete tools to optimize their production processes, tailor them to specific product requirements, and generate sustainable value over time.

March 16th, 2022 was not just a corporate acquisition, it was the beginning of a new era of growth, innovation, and global leadership.



# The Nipco™ Family



**Nipco™ I**



**Nipco™ WISE**



**Double  
Nipco™ I**



**Nipco™ HT**



**Nipco™ L**



**Nipco™ Hot**



**Nipco™  
Chaising**



**Nipco™  
Air Hybrid**



**Nipco™  
MultiFlex**



**Simili**



**Nipco™  
Embossing**



**Conventional**

# Index

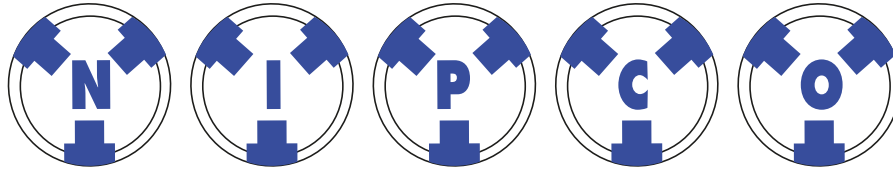

Nipco™ Technology	Page 1
Nipco™ I	Page 3
Double Nipco™ I	Page 5
Nipco™ L	Page 7
Nipco™ Chaising	Page 9
Nipco™ MultiFlex	Page 11
Nipco™ Embossing	Page 15
Nipco™ WISE	Page 17
Nipco™ HT	Page 19
Nipco™ Hot	Page 23
Nipco™ AirHybrid	Page 25
Simili Calender	Page 27
Embossing line for paper	Page 29
Conventional Calender & Entry - Exit Frames	Page 31
Covers & Sleeves	Page 32
Heating System	Page 33
Guarneri ReLife	Page 34
Spare Parts & Service	Page 36

# Nipco™ Technology for individual calender nips

Optimal process control in the calender Nipco™ roll systems

The timeline of an ingenious concept Nipco™

The basic concept behind today's Nipco™ roller was born in Zurich in 1971.

A short time later, the first version of this roll was operating in a paper machine.

Thousands of delivered Nipco™ rollers are testimony to the vast experience garnered from the most diverse sectors, including many outside of the paper industry.

This know-how led to new, product-oriented technology solutions for a vast variety of requirements.

The Nipco™ rolls today solid, reliable and maintenance-friendly roller concepts, allow each and every user to adjust the production process according to their product requirements.

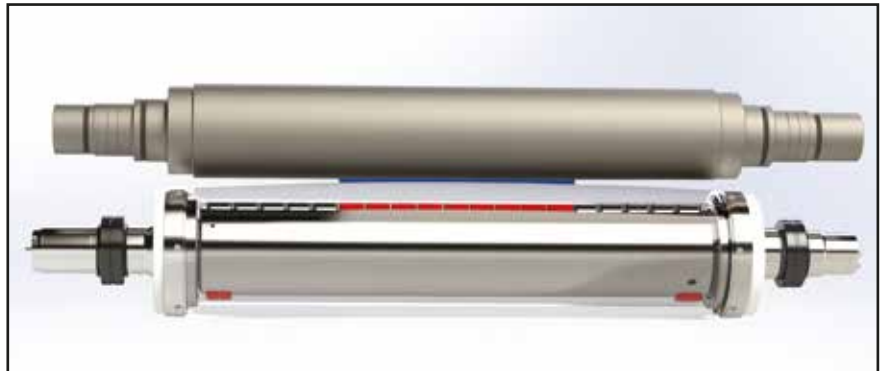
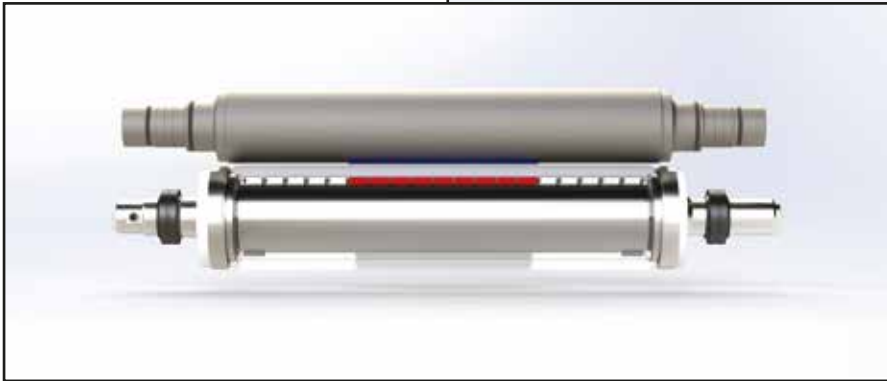

## The Nipco™ roll principle

A Nipco™ roll has three key elements:

- the stationary cross shaft
- the rotating roll shell
- the hydrostatic pistons

Of these, the cross shaft is the element that supports the entire roll structure. It transmits force from the calender into the nip.

The Nipco™ shell rotates freely over the cross shaft.

Either steel or highly flexible shells are selected, depending on the application case concerned. The surface temperature of the shell is controllable. Hydrostatic pistons individually installed in the cross shaft support the freely rotating roll shell against the load from outside. With the conventional Nipco™ roll, these hydrostatic pistons are actuated zone-by-zone. This allows individual line load curves over the entire width of the nip – even with the smallest linear loads.



### The result

Reliability and experience spanning over 50 years.

The individual force distributed across the entire width of the nip, regardless of the total force or the deflection of the counter roll, creates enormous adaptation potentials for the user. Even operation with a uniform parallel working nip is possible.

The individual force permits purposeful corrections, depending on the Nipco™ roll design. The effective width can be adapted to suit specific requirements.

### Applications

Tougher quality requirements, increasingly larger working widths and higher operating speeds call for market-oriented technologies that guarantee the best possible production reliability. The Nipco™ roll systems satisfy these criteria and are individually tailored to meet the needs of our customers. And the field of applications goes way beyond the paper industry.

From printing floor coverings or magazines to rolling steel plates or aluminum, from milling foodstuffs to finishing textiles and technical textiles. Likewise, these roll types are suitable for non-woven applications, such as thermal bonding.

For flexible use in various calender systems, smoothing and printing presses, embossing calenders or with the thermal bonding calender, the ideally formed print curve also rules out the risk of local over-pressing.

A Nipco™ roll system can usually be retrofitted into an existing system without major conversion effort, creating an almost endless list of applications for this roll system.

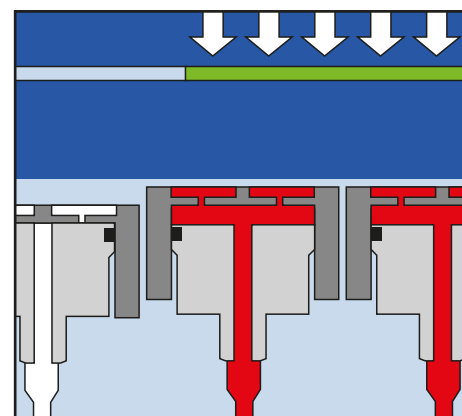

### Advantages

The use of Nipco™ roll systems allows the user to set individual forces in the nip. Consequently, the deflection curves of the shell can be adapted to suit the requirements concerned.

Depending on the roll design, operation with parallel nip is possible, i.e. the deflection of the Nipco™ roll precisely matches that of the counter roll. To generate this parallel nip, the Nipco™ roll shell is mounted equidistant to the counter roll, and the shell is precisely bent to the calculated deflection of the counter roll in a parabolic manner under the generated hydrostatic piston force. If the process demands that the force distribution is varied across the entire width, the hydrostatic pistons and/or hydrostatic piston zones are controlled zone-by-zone. A different pressure is applied to each zone.

In addition, the precise limits of the working width permits a gentle transition across the edge zones in case of different material widths.

This significantly improves the process result and reduces wear on the cover. With calendering, embossing, laminating and coating in particular, the individual advantages of the Nipco™ roll are key to a reproducible high product quality.

### Technical features

Linear loads 20–15.000 N/mm

Speeds 5 – 2.200 m/min

Product widths 500 – 12.800 mm.

Surface temperatures up to approx 300 °C

Sleeves: GTP6 - GTD3 - BiComponent - Steel - Rubber

Width adjustment for different fabric widths

Multiarea Pressure setting

Counter pistons for sleeve retracting to prevent edges overheating

	Effect and calenders type						
	Nipco™ I	Nipco™ L	Nipco™ MultiFlex	Nipco™ Chasing	Nipco™ HT	Nipco™ Embossing 2D	Nipco™ Embossing 3D
Smoothing	•	•	•	•	•	•2	•
Lustre	•	•	•		•	•*	•
High glaze	•	•	•				
Air permeability	•	•	•	•	•		
Soft hand		•	•	•			
Silk finishing	•*	•*	•				
Flat embossing		•*	•			•	
3D embossing							•
Down proof				•	•		

\* - possibile by changing rolls | 1 - With elastic counterroll | 2 - Possibile by changing sleeves

# Nipco™ I calender

## Efficiency through innovation



The Nipco™ I calender is an outstanding development of flexibility and efficiency in calender processing. The combination of a free rotating sleeve, whether a **GTP6**, **GTD3** or Steel covered by paper/cotton with our selective pressure adjustment in the width, will always prevent burning and marking of the sleeve edges.

The pressure is effective in only the requested zones, no other system in the market can compete with this function.

Other sleeves, when slid on, will over time start frictioning resulting in weft distortion.

### Contact time with respect to line load and speed

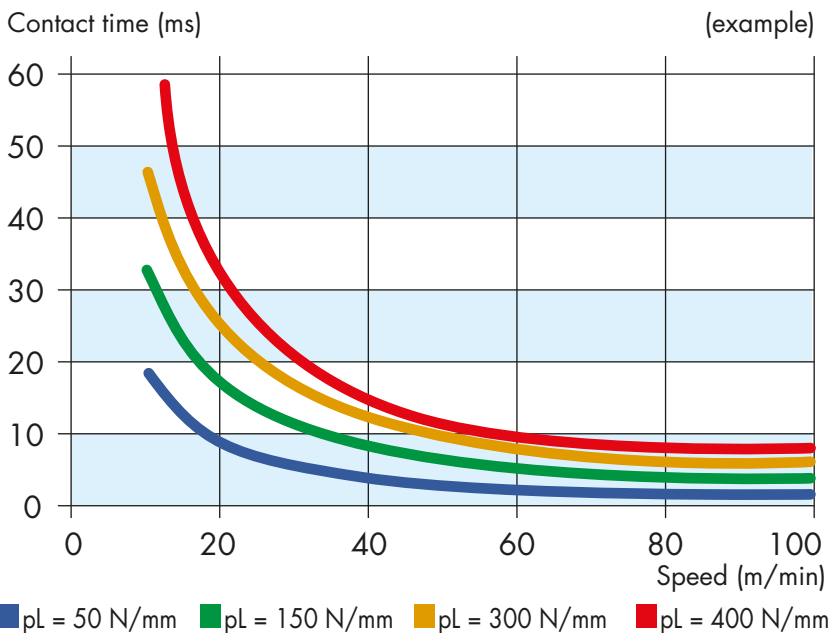

### Motorised width adjusting

An outstanding innovative development is the Nipco™ system width adjustment.

The motorised system will give a line pressure where it is needed, to suit the fabric width.

The motorised system can be programmed to load the pressure suit the fabric width, retracting the sleeve to avoid contact between sleeve and heated roller, preventing edge damage.

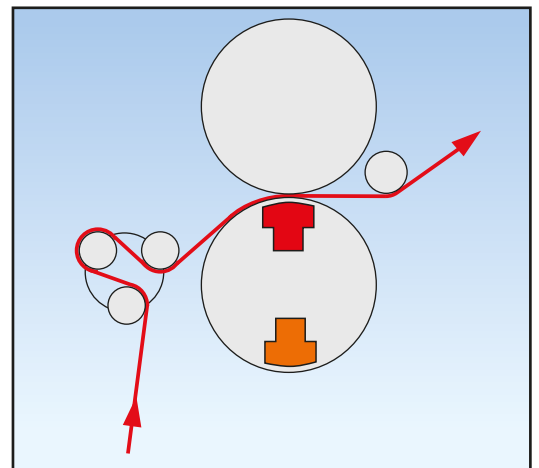

Fabric passage diagram

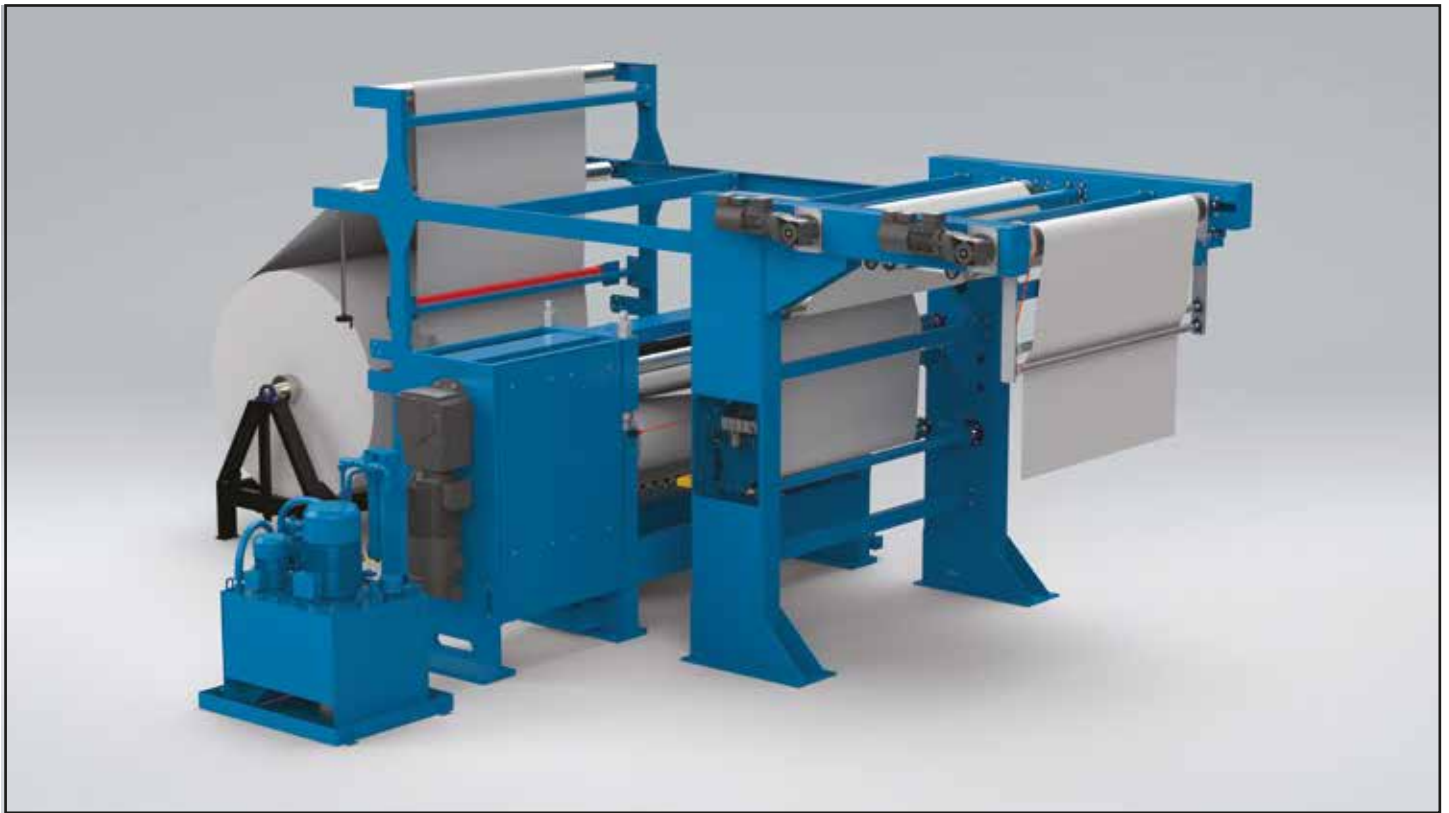

Our calenders are designed and manufactured in a self supporting way and are shipped completely assembled. Due to our calender manufacturing style, erection and commission take short time as they are already fully assembled with wiring and pipings already tested. No special foundation are requested.

#### YOUR ADVANTAGES

- Uniform line pressure distribution in the nip over the fabric width.
- Adjustable pressing width to suit change of fabric width under pressure without stopping production.
- Thermal relief of the sleeve next to the fabric by retraction forces, variable setting to prevent burning out and edge marking of the sleeve.
- Stepless selectable line pressure in the nip.
- Easy installation and change of any sleeve under consideration by our cantilever systems
- Same sleeve for the complete range of your fabrics in different widths.

Nipco™ I calender is the calender most performing for all kind of fabrics like shirting, home textile and technical textiles.

Line force up to 400 N/mm (infinitely adjustable) in combination with a GTP6 thermo-elastic polyamide sleeve or GTD3 duroplastic sleeve, offers various options for different finishing and a top-quality effect.

Thanks to the counter pistons, assembled at the opposite side of the main line pressure, the external sides of the sleeve, where the fabric is not present, are open like wings and not in touch against the hot steel roller, preventing the overheating and life of the sleeve.

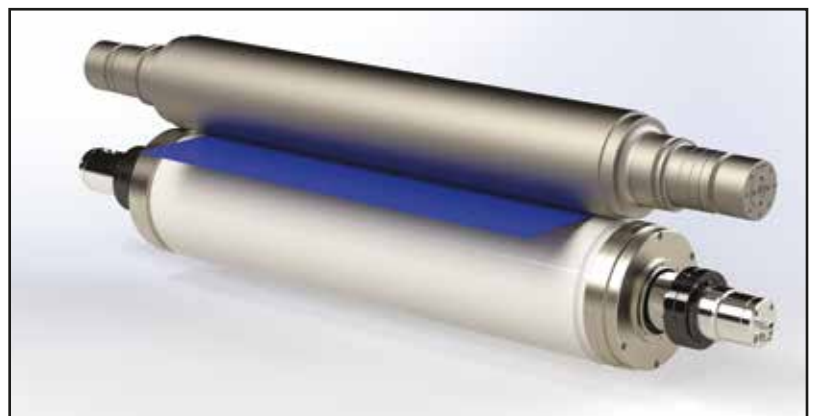

Rollers configuration

# DOUBLE Nipco™ I

## Double independent pressure lines

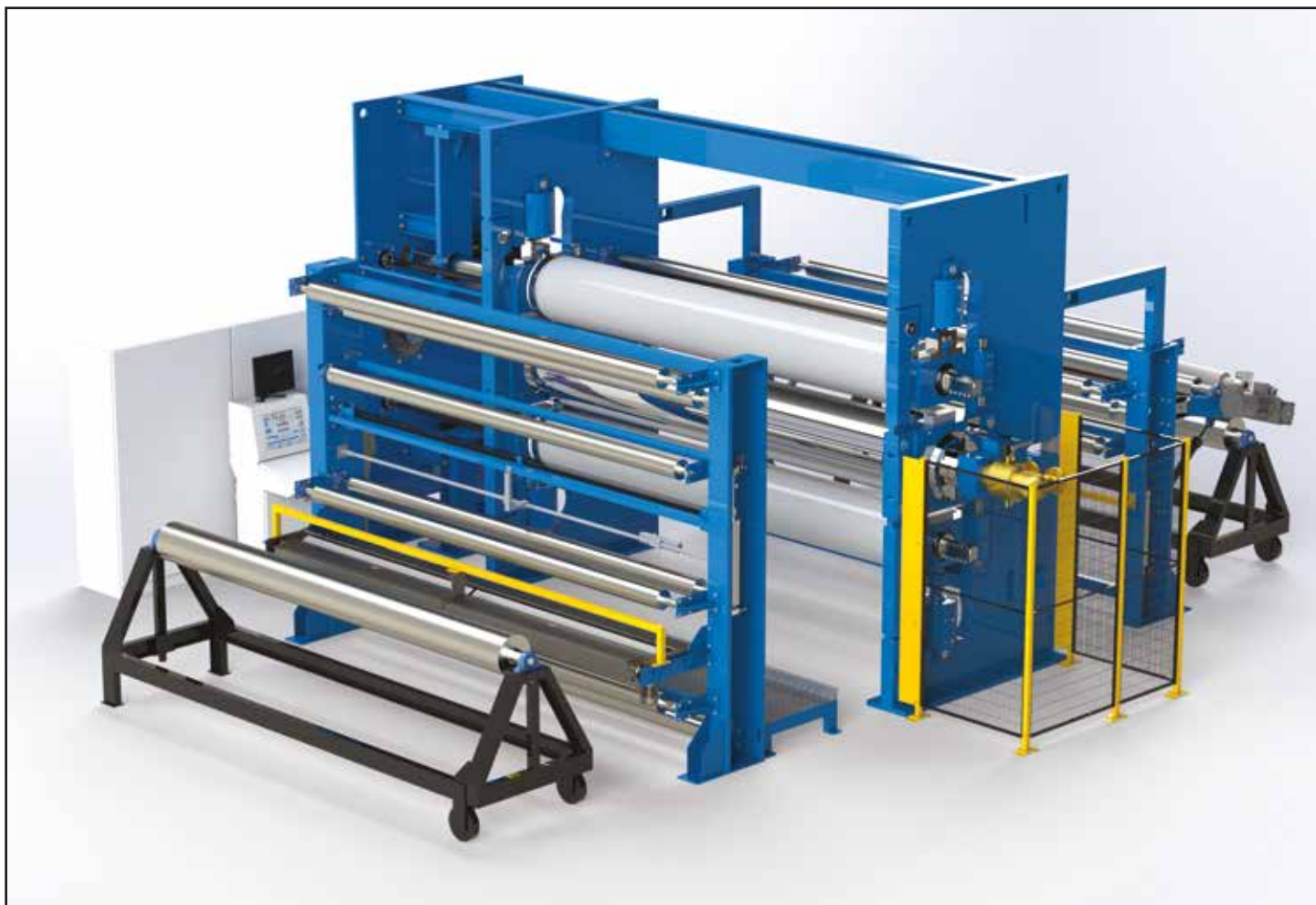

The **DOUBLE Nipco™ I** Calender is one further development for textile finishing.

Full flexibility in calender finishing for high lustre effects, using either one or both nips.

The pressure setting in each nip is independent and can be set between 50 and 400 N/mm.

Motorized width adjusting, automatically combined with pre-selection of retracting forces.

The pressure across the width can be automatically set to fabric width, thus allowing the pressure to be released in the non-fabric area and protecting the sleeve from burning.

Customers can select either **GTP6** thermoplastic sleeves, **GTD3** duroplast sleeves or Steel sleeve covered by paper/cotton.

Also the DOUBLE Nipco™ I in conjunction with our Nipco™ HT version is available for zone controlled pressure settings.

With the technical innovation of Guarneri Technology our customers can stay as a market leader in textile finishing.

The Nipco™ Technology does not have any limitation in terms of process and finishing effects.



Our latest development: **Your Benefit To Become Market Leader In Precision**



Displayed on 15" touch screen, all individual settings have to be retrievable in a qualified recipe management. Therefore all our calenders are equipped with Siemens S7 computer systems for recipe control, maintenance announcements, service requirements etc.

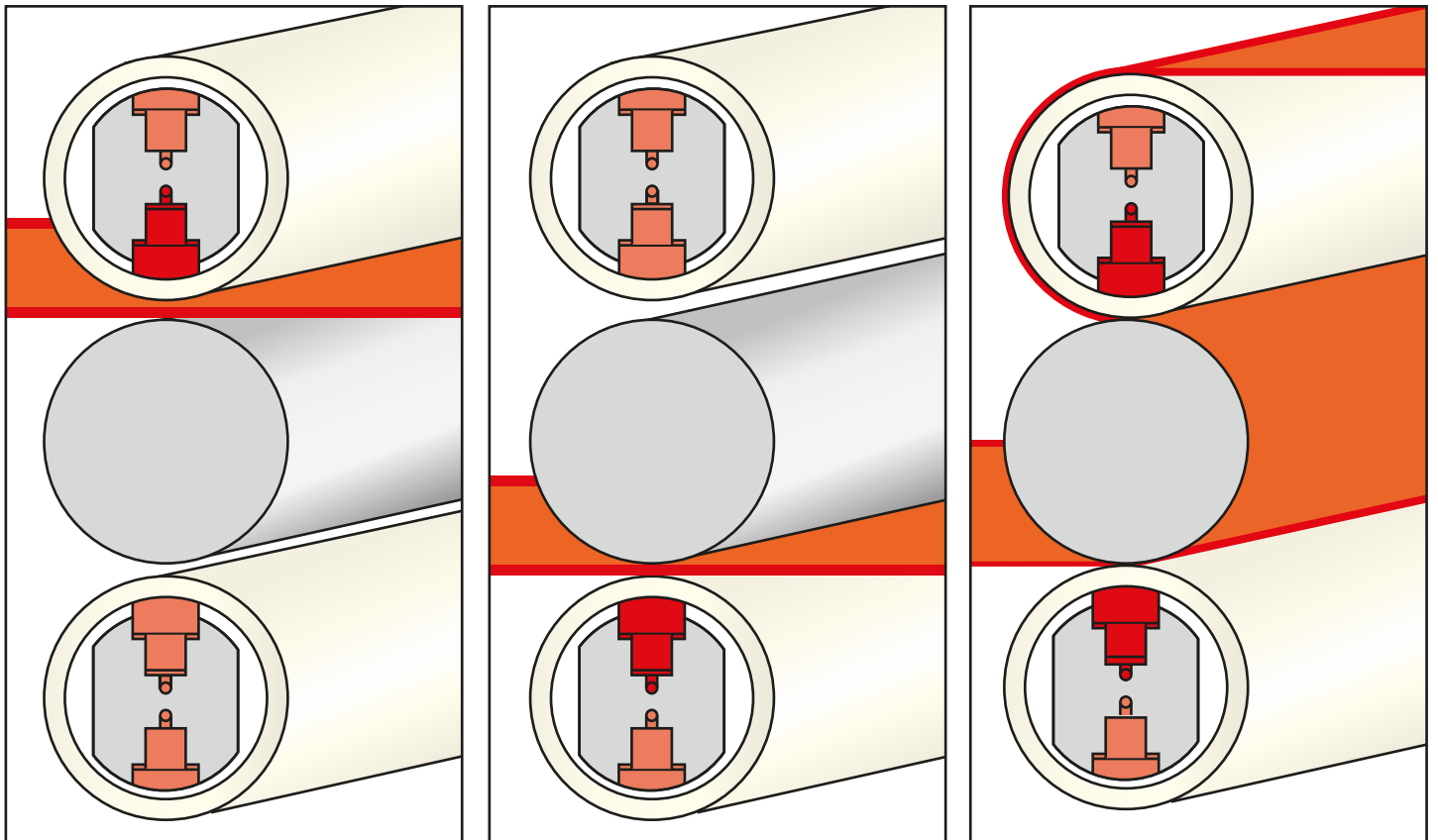

Fabric passage in the top nip

Fabric passage in the bottom nip

Fabric passage in both nips

#### Your advantages

- Individual zone controlled pressure setting
- Pre selecting of required pressured line profile
- Reacting on edge elongation by zone controlled pressure reducing

# Nipco™ L calender

## The star among calenders

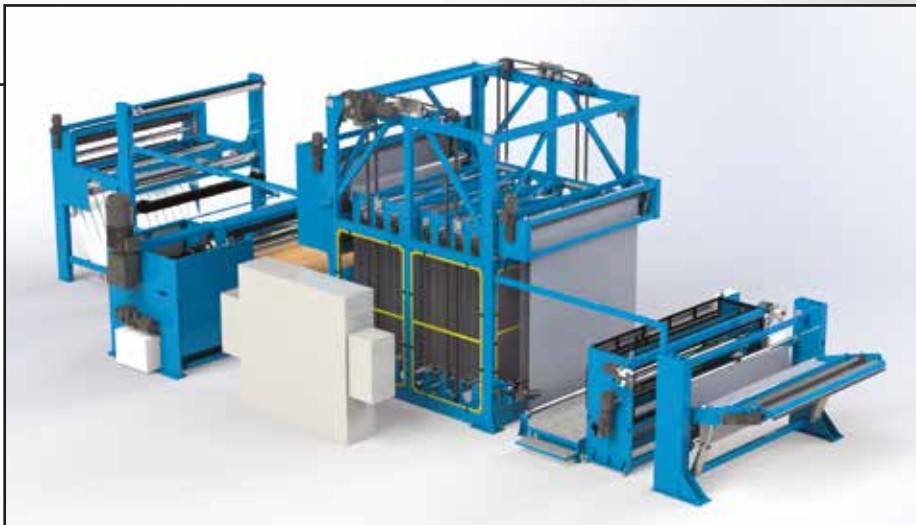
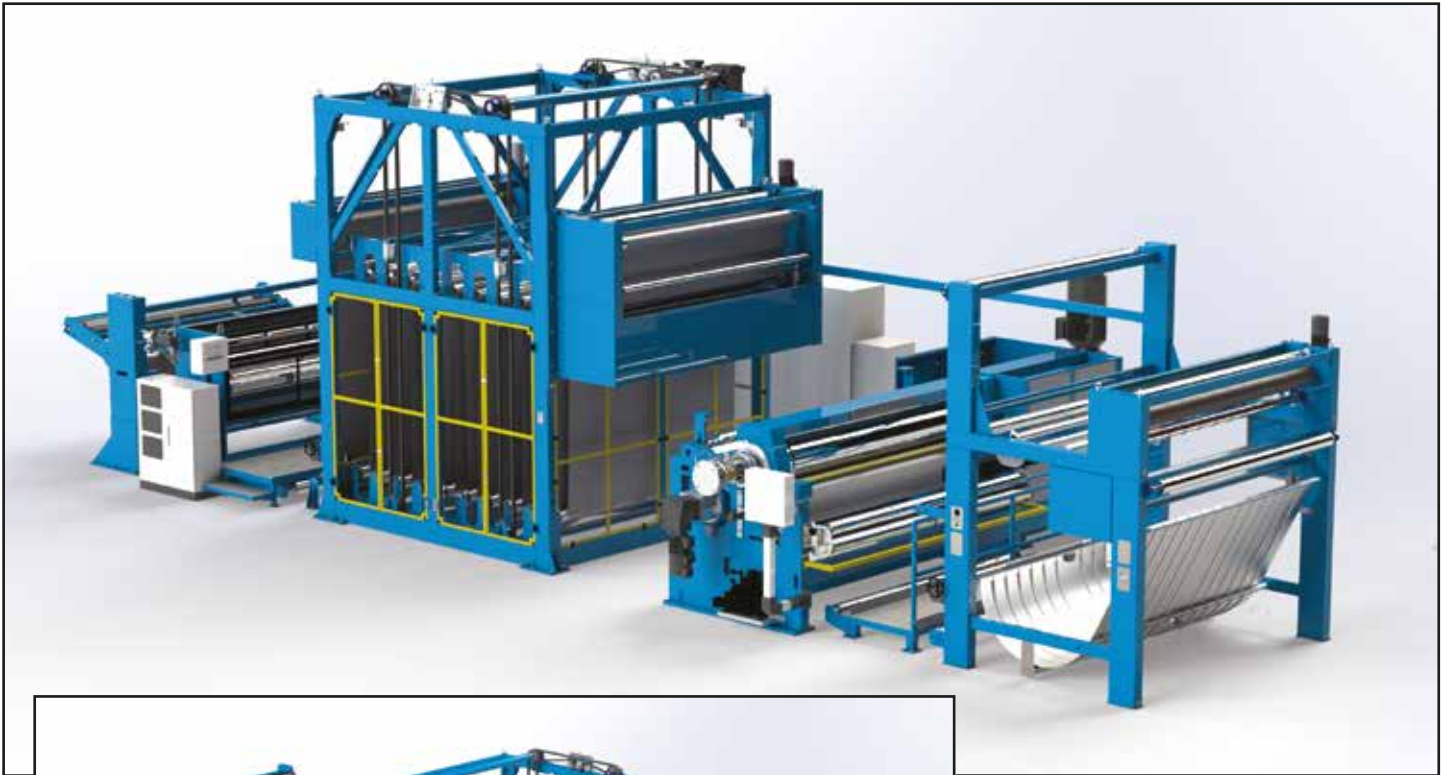

With the development of the Nipco™ L configuration Guarneri Technology has the exclusive right to continue with the concept first introduced in the 80s.

A textile finishing calender with two nips with independant pressure settings, a revolution in calender technology. The system allows you to select effects, high glazing, softness, density control and other sales requirements combined in one calender .





Whether producing shirtings, ladies fashion, underwear, bed sheets, table linen, home textiles or protective clothing, the system allows you to compete in the market. The hydrostatic support elements of our Nipco™ L system are independently arranged in a 90° configuration, one active against a steel bowl, one active against a cotton bowl.

The stabilising force angle of 270° will at all times guarantee a free and uniform turn of the sleeve using either a Thermoplast as **GTP6** or a Duroplast as **GTD3**.

With those independent pressure lines in action you may "play" with your pressure settings. High glazing: increased pressure in the nip Steel/Nipco™ **GTP6**, same time slightly reduced glazing and softer handle, decreased pressure setting in the nip Nipco™ **GTP6**/Cotton.

Elegant glazing and remarkable softness in handle: decreased pressure in the nip Steel/Nipco™ **GTP6**, same time increased pressure in the nip Nipco™ **GTP6**/Cotton. Only the original Nipco™ L calender today offered from Guarneri Technology controls two pressure lines completely independent based on patented development of the 80s; a development of former Escher Wyss, presently VOITH today took over by Guarneri Technology.

### YOUR ADVANTAGES

- Two completely independent pressure lines are active in one calender at the same time
- Uniform pressure lines in two nips with pressure lines according to market requirements'
- Two selectable pressure lines in the range of 25 - 400 N/mm
- Width adjusting according to different fabric widths in order to protect out burning and marking of the sleeve
- No friction in the nip caused by slide on sleeves to the process bowl
- None computer supported force comparison between outer forces and inner deflection compensating forces
- Easy sleeve change by our cantilever system

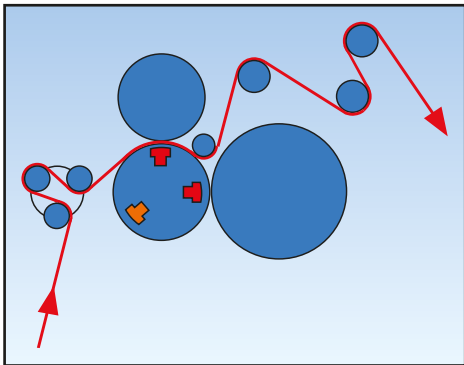

Fabric passage=reduction of air permeability, lustré

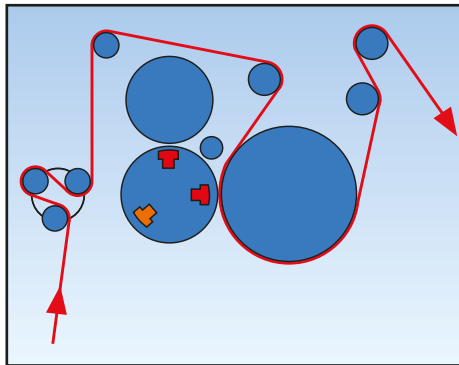

Fabric passage=soft hand

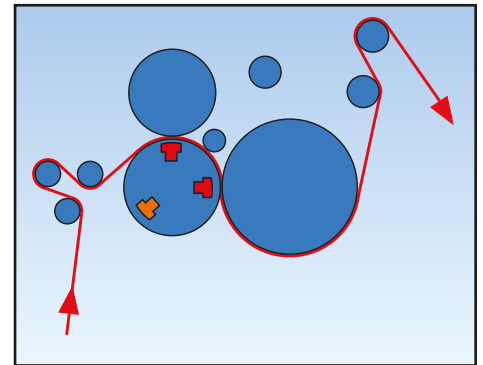

Fabric passage=combination lustré and soft hand

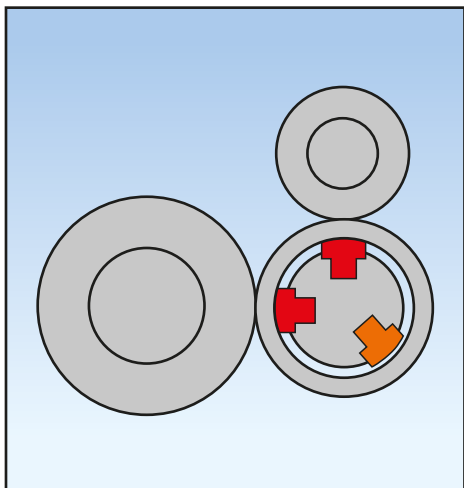

Arrange of the support sources

### Effects as a function of the changing physical parameters

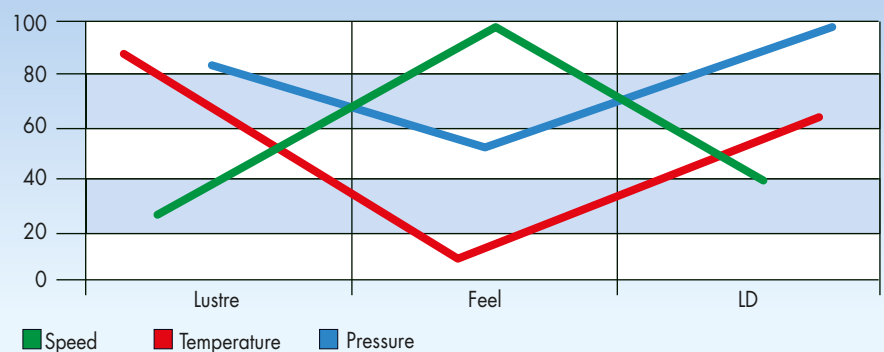

# Nipco™ L and Nipco™ Chaising calender

## The optimal combination



Nipco™ Chaising calender each with one Nipco™ roll in top and bottom position

### Nipco™ Chaising calender: Your advantages

- All 5 bowls cylindrical
- Nipco™ bowls in top and bottom position to avoid deflection and bowl crowning
- Pressure adjusting in accordance with the known Nipco™ technology
- All rolls with same diameters which is most important to have the expected result
- Unique web guiding in in feed and out feed to avoid wrinkles
- Special web guiding to avoid any elongation, which requires a specific know how of all Engineers being involved

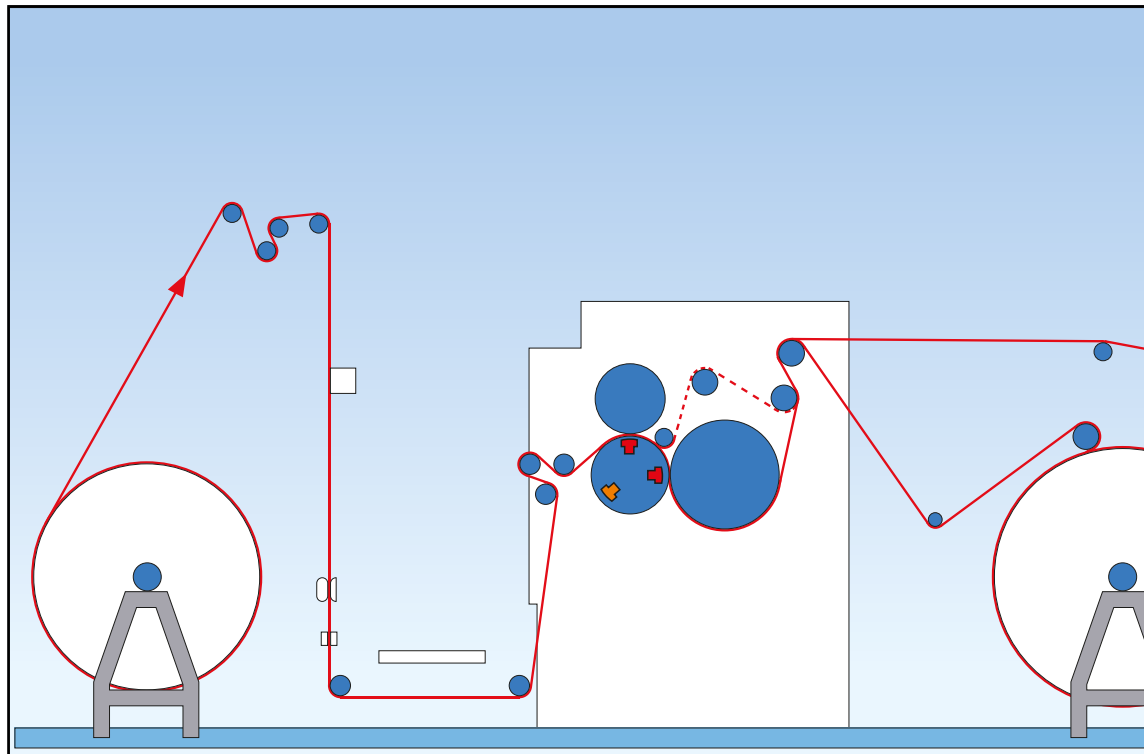

Combination Nipco™ L and Nipco™ Chaising calender



If in qualified markets a qualified down proof fabric is required with full and soft handle, a technology returns, which in the 50s and 60s was standard all over the world. Latest with the development of polyamide GTP6 bowls **Chaising Technology** was setting new standards; with developing of the Nipco™ technology the full range of independent pressure settings instead of crowning the bowls has given full flexibility to this special calender finishing.

Textile fabrics out of cotton or linen, like down proof, damask, mattress drill or bed linen have been finished for many years on so called mangling or "**Bettle**" equipment, the target: soft, full handling with elegant glazing and "deep results", means not only a surface finishing, but a finishing with effect of depth!

The answer has been given by the so called "Chaising Technology", in which the woven cloth is packed in 5 - 7 layers from inside to outside in those 4 resp. 6 nips, one on the other. Warp and weft threads grip into each other and are not "over pressed" but ideally filled.

A result the yarn is given natural "roundness" and this means mangling and full grip. In Chaising calenders a Steel bowl is never used, only soft calender rolls like cotton or GTP6.

If such a Chaising unit is combined with a so called pre calender unit, like Nipco™ L with its possibilities of independent pressure setting in two independent nips, you will reach your optimised result, which will not find any technical alternative.



Nipco™ Chaising calender

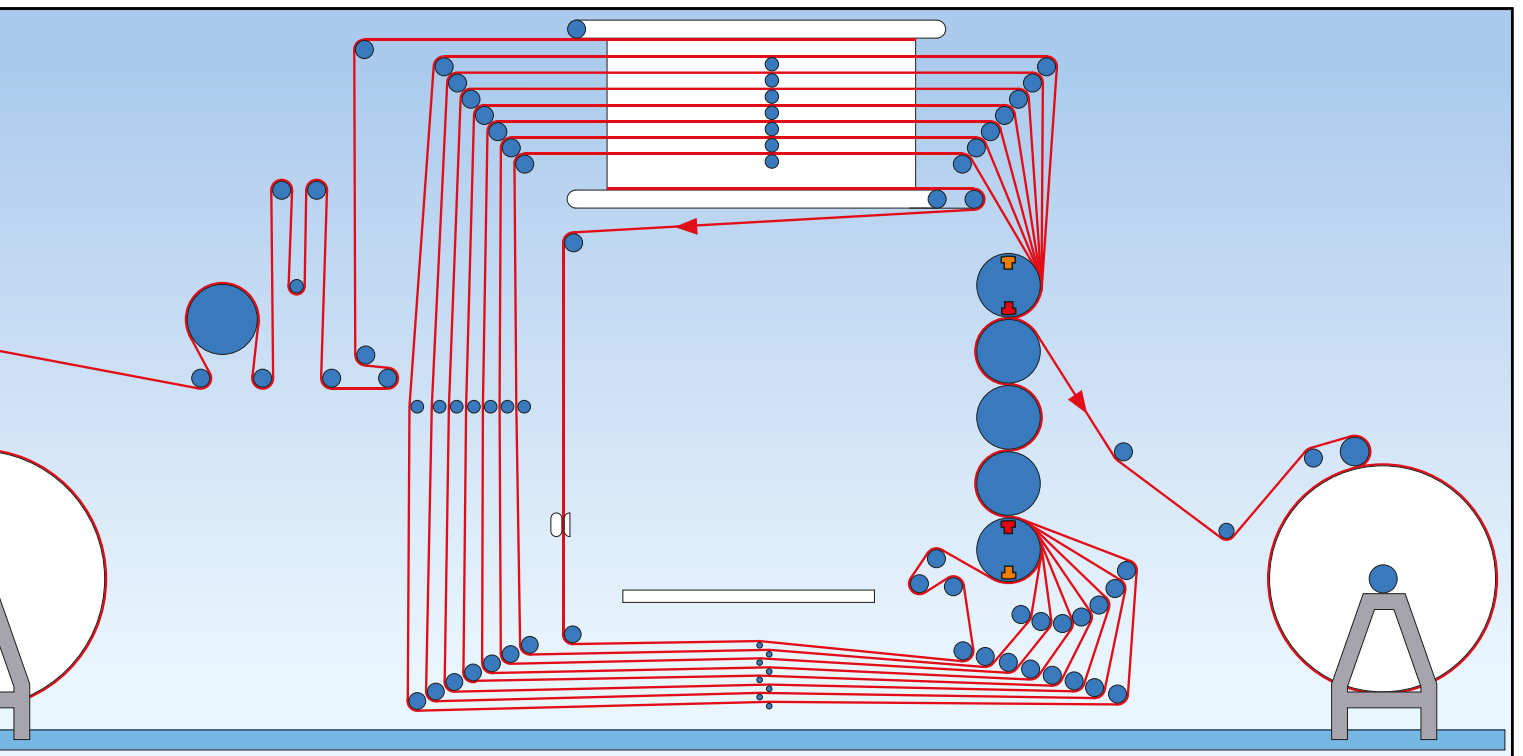

# Nipco™ MultiFlex

**The first textile calender with 5 bowls and 3 independent lines**

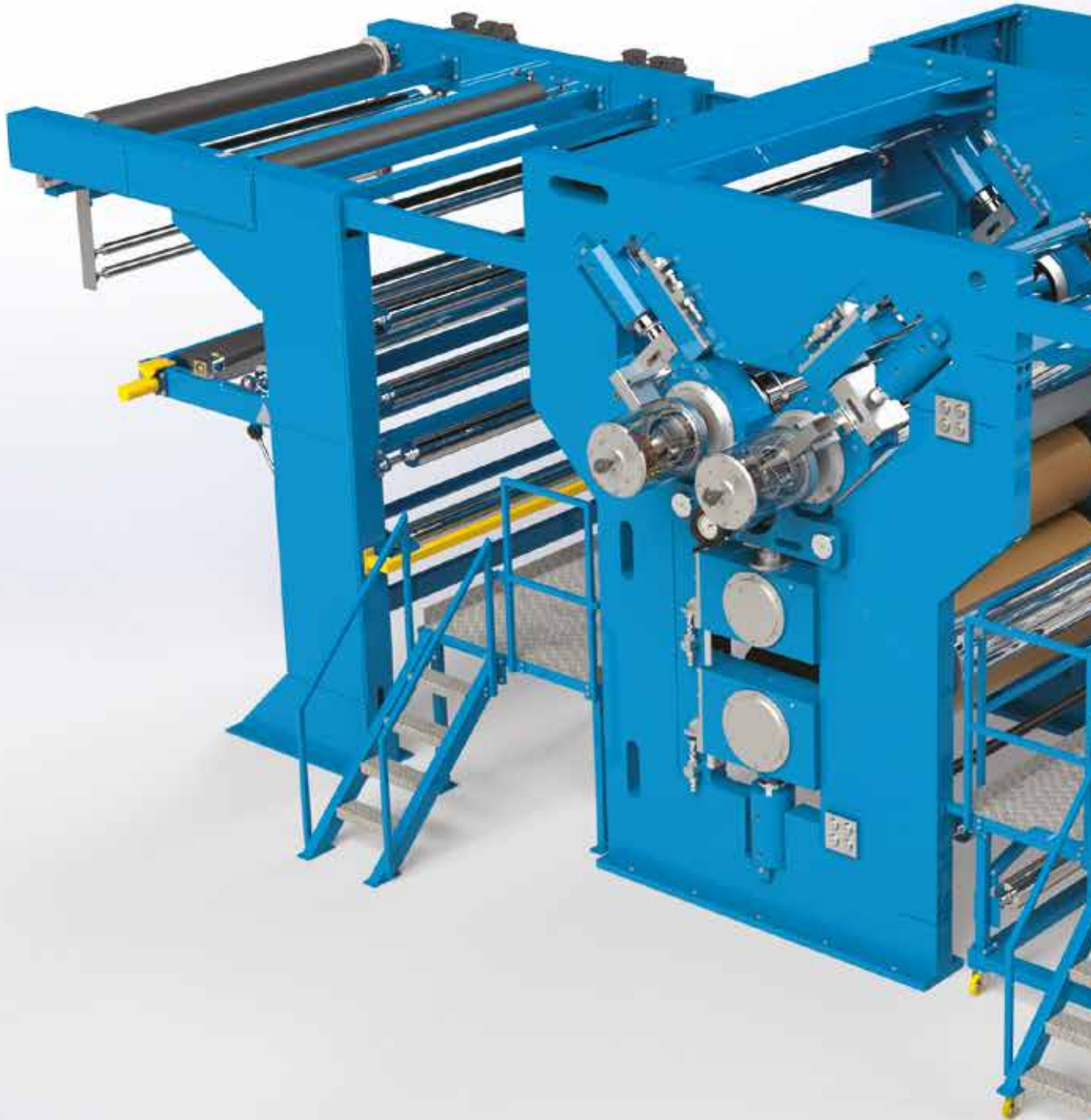

# More glaze, more density, softer touch, more flexible embossing and area controlled pressure lines

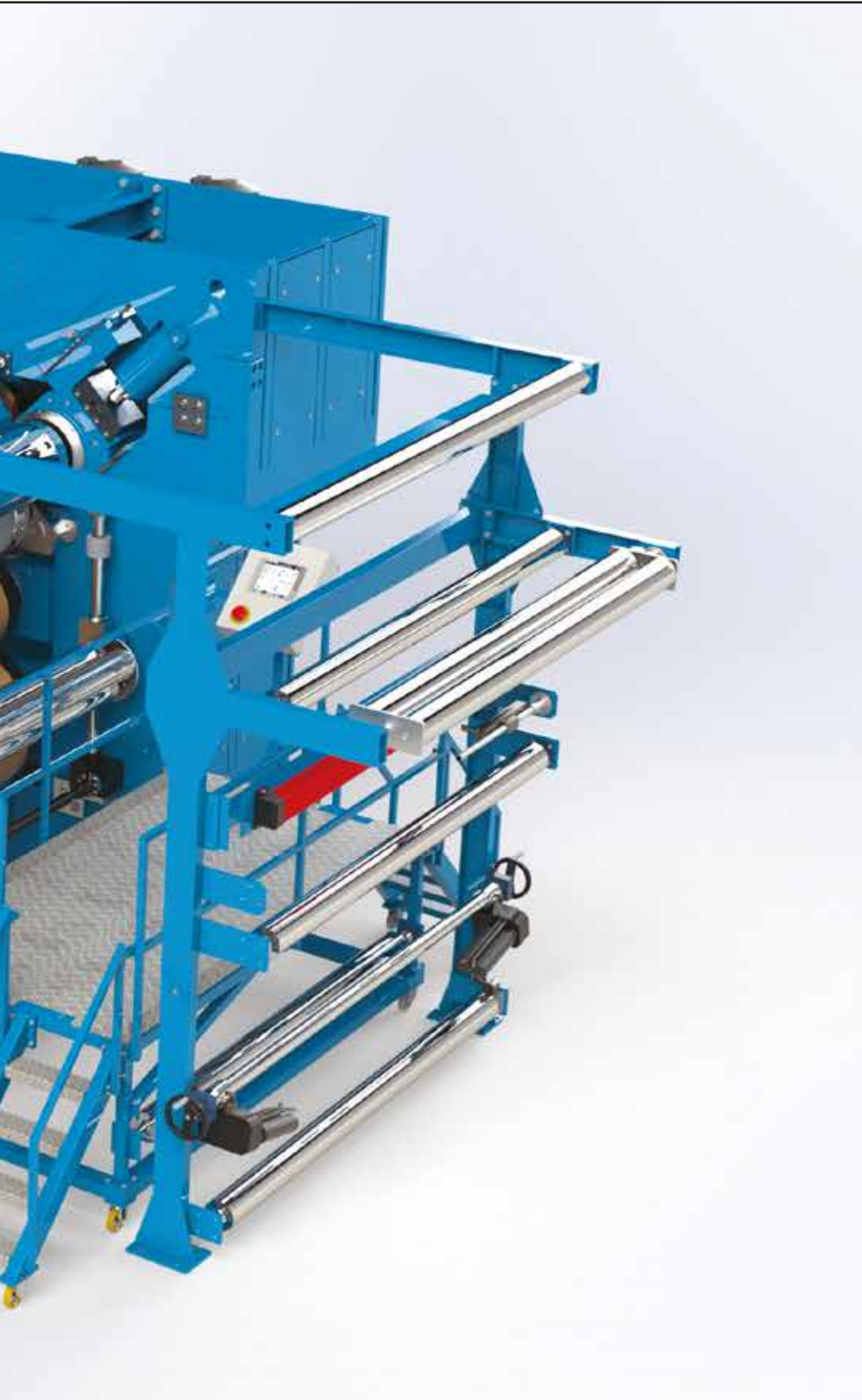

Our development has been the so called Nipco™ HT, a Nipco™ bowl with flexible pressure setting across the width, for finishing of technical textiles, the most important development over the last years and the Nipco™ covered with cotton or paper.

Now, we are presenting one step further: a new Nipco™ system bowl with three independent pressure lines, each pressure line individually controlled and area controlled, if requested.

This Nipco™ **MultiFlex** calender to be used as embossing machine, e.g. for automotives, for highest lustre and soft touch in many textile applications.

The so called CHINTZ effect has now been optimized. Two steel bowls acting against either GTP6 or GTD3 sleeve, give a magnificent result. The centre Nipco™ system bowl has 3 independent pressure lines and at any time two of them can be combined to reach your targets, the third pressure line is then acting as stabilizing retracting line.

Optimal effects through 3 separate operated pressure levels in one single working process.

Nipco™ MultiFlex the first 5 bowls calender with two hard nips Steel/GTP6/Steel and two soft nips combined between GTP6/Cotton and Cotton/Cotton. Same basic equipment to be used as MultiFlex embossing calender by replacing both steel bowls by two engraved bowls with individual design. Most interesting for automotive applications, e.g. for seat cover embossing, even with 3 embossed bowls to be combined instead of the cotton bowl underneath.

# Optimal effects through 3 separate operated pressure levels in one single working process

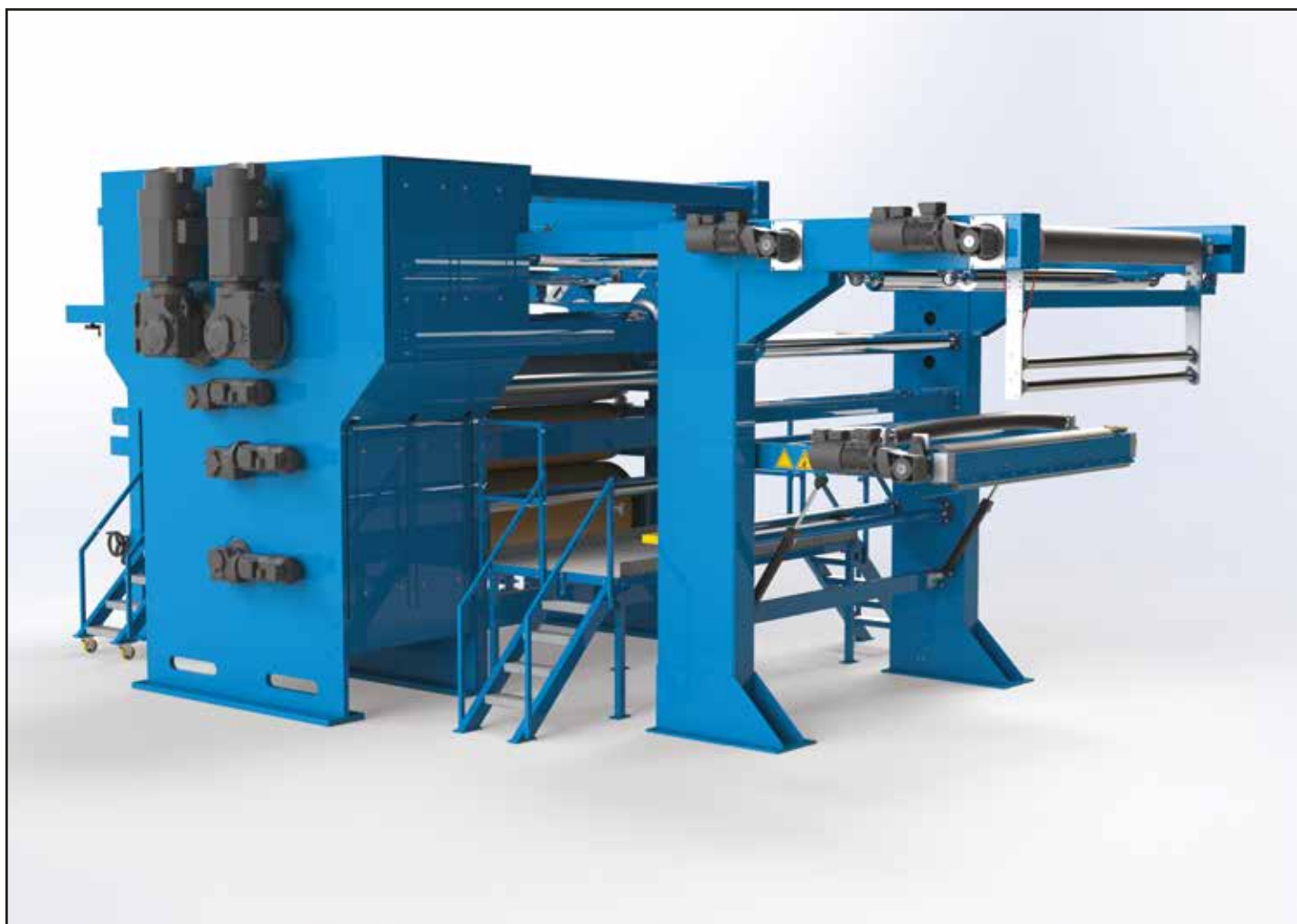

## YOUR ADVANTAGES

- Universal calender with high production speeds.
- Up to 5 bowls, composed by max 3 pressure lines. Each pressure line individually and independently controlled across the width.
- No more pre-calendering operations, as all requested results are now combined in one machine.
- More shine, more lustre, more textile touch and more softness than ever obtained with a calender.
- Different fabric passages, each pressure line individually controlled through proportional valves.
- All functions are controlled and reselectable by 'Siemens S7' software.
- Multi-purpose embossing unit with 3 embossed steel bowls, each one individually selectable.
- 3 pressure levels, 1 working process.



Rollers configuration



# Different fabric passages

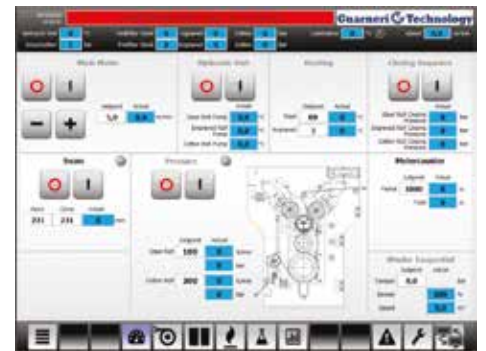
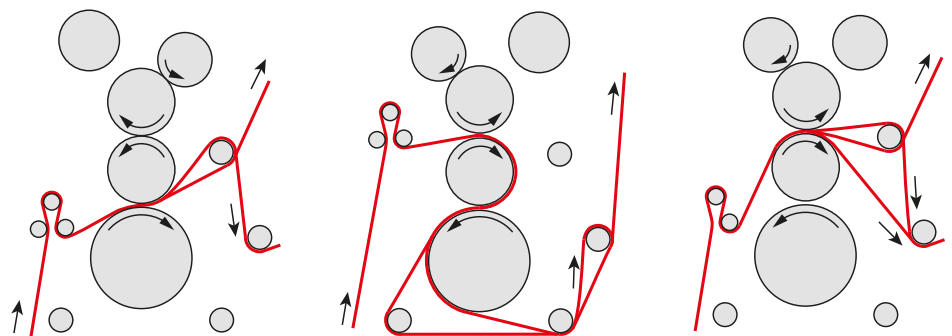
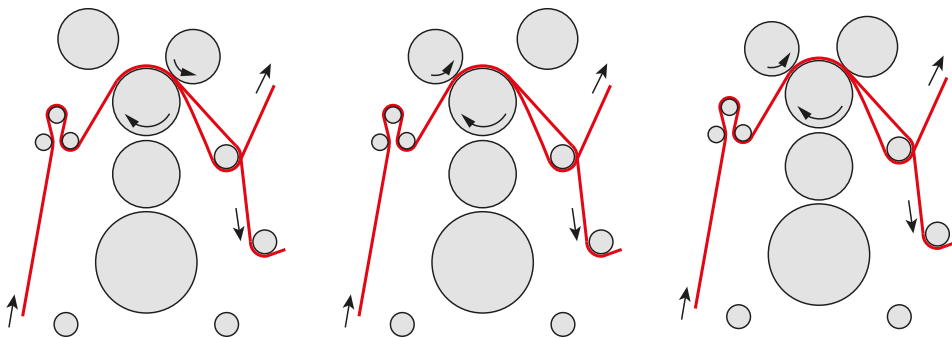
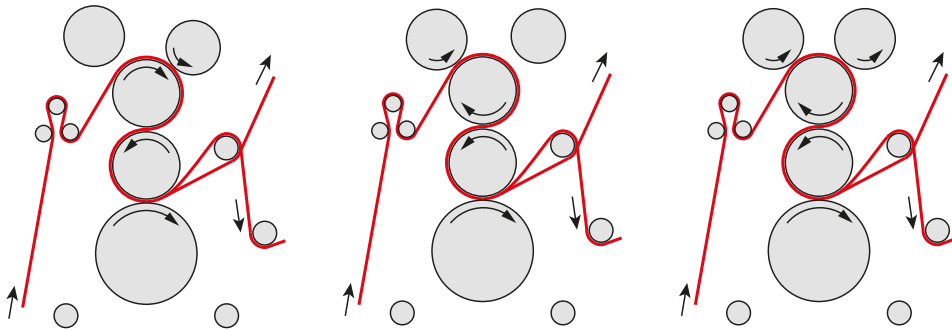

The 5 bowls of this new generation of Guarneri Technology.

Nipco™ **Multiflex** calender offers the possibility to select the most suitable fabric passage among several combinations.

By using the Nipco™ Technology, in its defined nip configuration for embossing effects, the calender offers the possibility to select, through a 'revolving system', one of 3 different designs without changing the bowls.

All nips are controlled by this well known Nipco™ system combined with one soft nip, cotton/cotton, as to where a small diameter cotton bowl is acting on an enlarged cotton bowl, reaching a result close to frictioning. This means highest density and most softened touch.



# Nipco™ Embossing calender

## Additional effects for more flexibility

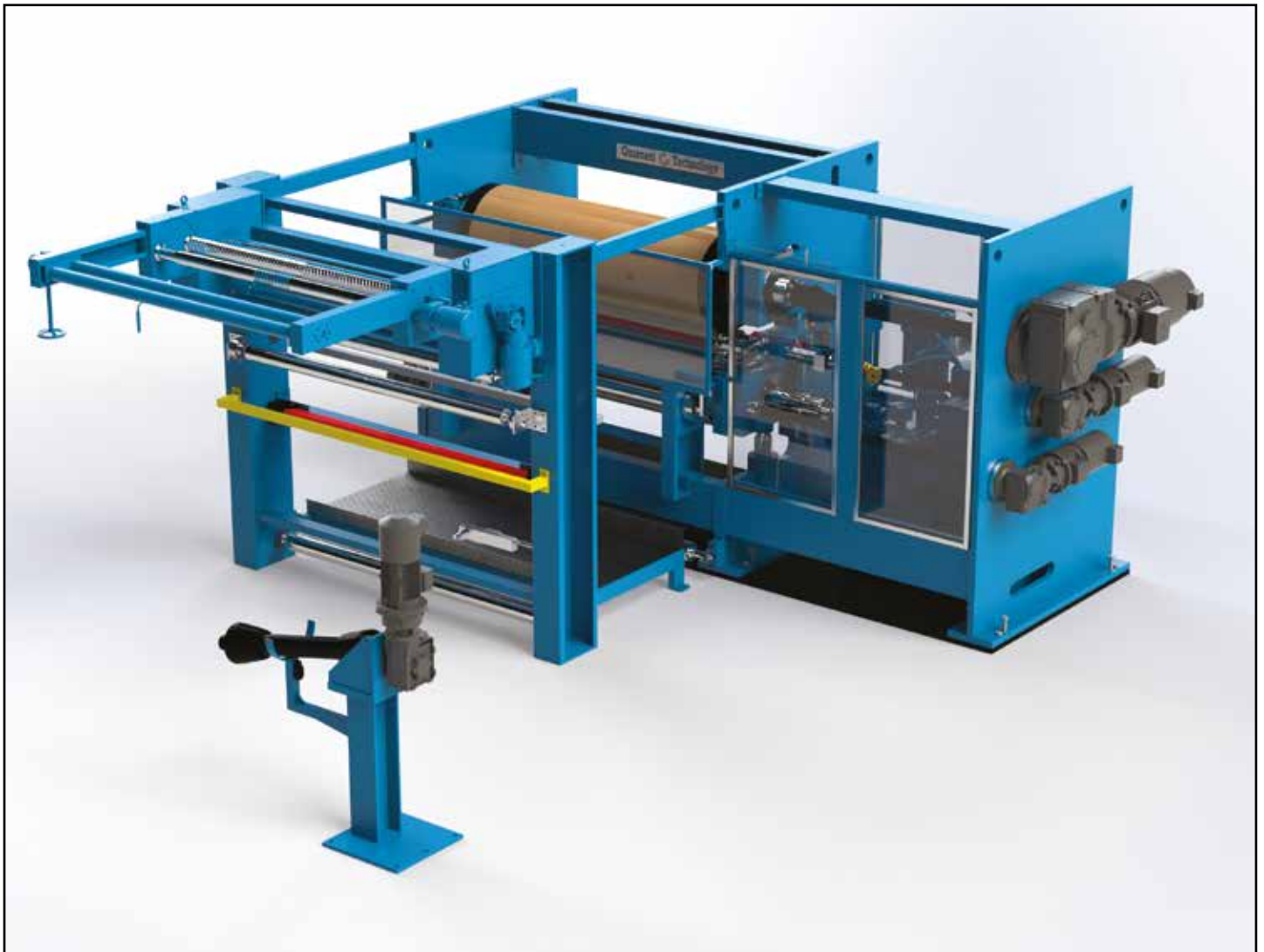

Nipco™ embossing calender

### Your advantages

- Uniform line pressure distribution in the nip over the fabric width.
- Adjustable pressing width to suit change of fabric width under pressure without stopping production.
- Infinitely selectable line pressure in the nip.
- Thermal relief of the **GTP6** sleeve next to the fabric by retraction pistons to ensure a long roll sleeve life.
- Cylindrical rolls.
- Same sleeve for various fabric widths; no change of sleeve necessary.
- Relief from thick fabric selvages (Sulzer selvages) and gentle treatment of the selvages of knitted fabrics by line force adjustment in the edge zone.
- Easy installation and removal of the **GTP6** sleeve and engraving tube through shaft extension and clamp holder.
- Reduction of engraving costs through small tube diameter.

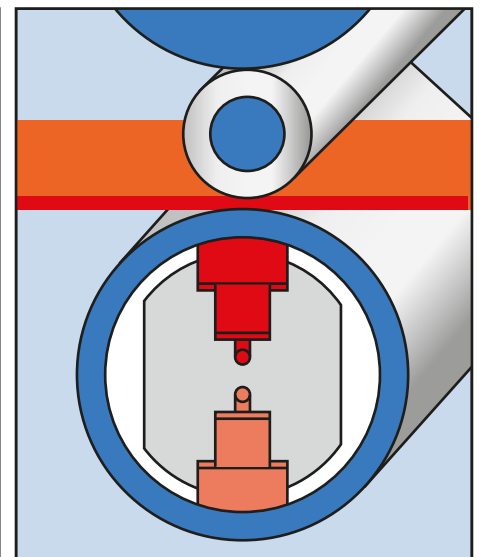

Embossing calender with mandrel and tube



In order to achieve optimal effects with different embossing designs, different calender pressures are essential.

This is where the Nipco™ embossing calender with its application advantage of providing nip compensation when using different calender pressures comes into use.

The advantage lies in the absolute assurance of nip compensation when employing various calender pressures.

The Nipco™ embossing calender can be used as a 3 roll or 2 roll calender.

### **Nipco™ 3 roll embossing calender**

The 3 roll calender is available in the following roll arrangements, from top to bottom:

- elastic supporting roll
- embossing tube/mandrel
- Nipco™ roll

The narrow, thin-walled engraving shell runs on a heated mandrel supported by the elastic and Nipco™ rollers.

This calender is optimal when the production sequence requires frequent changing of the embossing sleeve, even several times daily.

Further advantages of the 3 roll version are the low price of the embossing sleeve due to the small diameter and the engraving cost for the same.

The aforementioned roll arrangement enables problem-free application of all flat embossing designs. The embossing sleeve change - an important production factor - can take place in the shortest time. This is made possible by a special bearing construction, as well as the mandrel extension with clamp holder.

The sleeve is dismantled of the heated mandrel from one side. This construction obviates the necessity of changing the heating system (electric or oil heating) in the mandrel.

Deep embossings can also be achieved with the 3 roll combination, whereby the use of a special embossing belt made of an elastic material for protection of the Nipco™ roll is necessary.

This embossing belt can be fitted or removed in the shortest time owing to the optimal machine construction. The material of the embossing belt ensures high reproducibility of the required embossings and effects and has a long life expectancy.

High glaze, lustre and compression processes can also be achieved with the same machine type when using a smooth steel tube.

### **Nipco™ 2 roll embossing calender**

The 2 roll version of the embossing calender has the following roll arrangement, from top to bottom:

- Nipco™ roll
- engraved steel roll

With this calender type, all flat embossing effects can easily be achieved.

Deep embossings can also be achieved by using an embossing belt for protection of the Nipco™ roll.

This 2 roll version has a higher pressure in the basic machine, so that improved high glaze, lustre and compression effects can be achieved when using a smoothing roll.

The roll change (embossing roll/smoothing roll) is more time-consuming than with the 3 roll version.

For embossing special articles - plush or other pile fabric - these Nipco™ embossing calenders are provided with the necessary additional equipment, such as brushes, pile layering apparatus and needle tension rolls.



# Nipco™ WISE Edge control system



## WISE - Edge Control System

With a Nipco™ roller system, the entire material surface can be supplied with a very homogeneous linear load distribution.

The system can either be equipped with a classic width setting device, a zone control for individual line load control or a newly developed "WISE Edge Control System".

The WISE functionality enables a locally influenced line force, corresponding to the fabric edges.

The edge zones of the materials are always subject to special requirements, since the material can deviate slightly from the central area due to preliminary processes.

This system enables our customers to drive the edge area with different linear forces than the central area. As a result, higher line loads can be applied to the material at the edges.

The effective width of the WISE system is adjustable and can also be adapted to the respective material width. This unique technique allows our customers to have a better control of the line load distribution throughout the material.





**Example of how to manage a Nipco™ I WISE width 2.000 mm. and consequently its 19 pistons**

Thanks to the width adjusting device is possible to set different pressures in step from 100 to 300 mm. on the edge zones, in order to prevent any defect at the edges of the fabric (see images below).



Nipco™ I WISE with selected width 1.900 mm.

Here we have 3 independent pressure zones, a central one with 15 pistons (red – 1.500 mm.) and two later zones with 2 pistons each (yellow and blue – 200 mm.)



Nipco™ I WISE with selected width 1.500 mm.

Here we have 3 independent pressure zones, a central one with 13 pistons (red – 1.300 mm.) and two later zones with 1 pistons each (yellow and blue – 100 mm.)



Nipco™ I WISE with selected width 1.300 mm.

Here we have 3 independent pressure zones, a central one with 9 pistons (red – 900 mm.) and two later zones with 2 pistons each (yellow and blue – 200 mm.)

The width can be selected manually by handwheel or by an operator panel through a motor with an encoder managed by a PLC.

# Nipco™ HT Calender

**The first calender with flexible zone controlled pressure setting across the width**  
**Headstart in calender design through continuous development**



Our latest and most important development over the last years: the Nipco™ HT calender, a Nipco™ roller with flexible pressure setting across the width, for finishing of technical textiles.

## **The Challenge**

The industry of Technical Textiles is growing all over the world. Day by day we recognise, that customers' demand is not only growing in quantity and areas of application, but also in terms of technical demands. Enlarged weaving width, for instance, has several upcoming challenges to face: Problems regarding the evenness across the width, the side to side unlevelness, slack edges, bulbous center areas. All these require a calender technology, which is able to compensate those problems.

## **Our Answer**

Area controlled pressure setting across the width, individually adjusted to customers' demands, based on our famous Nipco™ technology executed in more than 1.000 calenders sold worldwide.



# How to control the air permeability

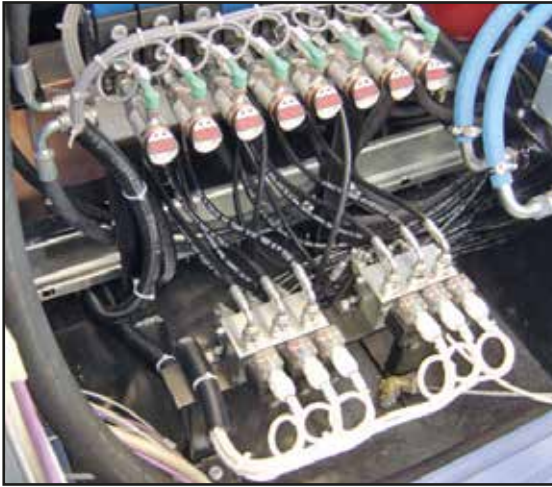

Our Nipco™ HT hydraulic unit is based on two separated control sections: The first one is related to the independent zone controlled pressure setting. The second section is dedicated to the movement of the Nipco™ roll from ground to working position. In first section, we integrated a zone controlled pressure setting from 5 to 15 zones, selectable on customers' demand. All pressure setting in this control group is done by proportional valves. We connected two pumps to the main hydraulic motor. The first pump activates the outline cooling circulation. The second pump activates the counter, i.e. the so-called retraction pistons. The second power group is responsible for lifting up the Nipco™ system bowl in working position, synchronising left and right sides. This second unit is required, if heavy material has to be finished and a prior gap setting is not recommendable. Both hydraulic groups have been executed with electronic proportional valves. Those valves are activated via the integrated Siemens S7 with digital control from 4 to 20mA, corresponding to a range of 50-400 N/mm. All proportional valves are equipped with a pressure transducer and a relevant display showing the pressure of each zone under control in bar.

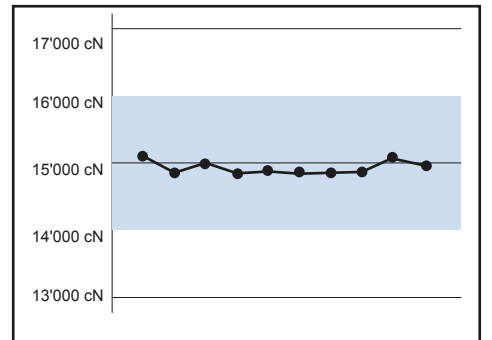
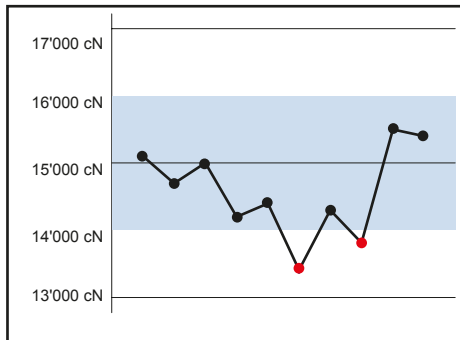
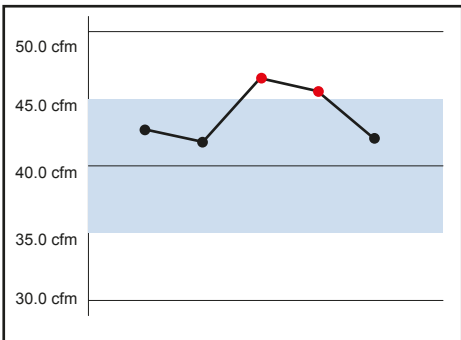
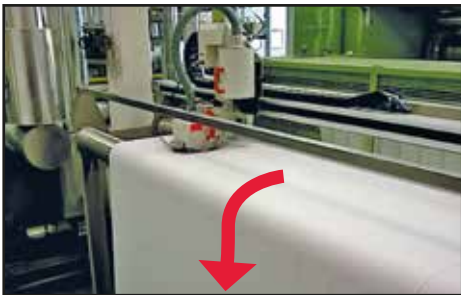

During calender finishing of technical textiles, one frequently occurring target is the defined adjusting of air permeability values. Therefore, a measurement instrument should be installed in the calender exit.

Whenever a measured value is not within the defined range of allowed variation, this will be shown on the touch screen. Based on this information the operator will then react in correcting the pressure setting in this area, via the Guarneri Technology zone controlled Nipco™ HT system bowl.

Once again **Guarneri Technology** is setting standards in calender technology. Constant development, based on customers' demands, is our daily business. The satisfaction of our clients' needs is our prior target.

# Nipco™ HT Calender Technology

## The basis of our success

Since first delivery of a Nipco™ technology on textile calender in the late '70s our customers are used to select the active pressure line by synchronised width adjustments. Pressure is given in an even and precise load according to material width.

Our philosophy: press where load is required but never outside the working width.

With this technology we protect the sides of the turning sleeve, which are not covered by material, against any damage like overheating or marking by woven selvedge. Our philosophy behind: pressure setting where pressure is required

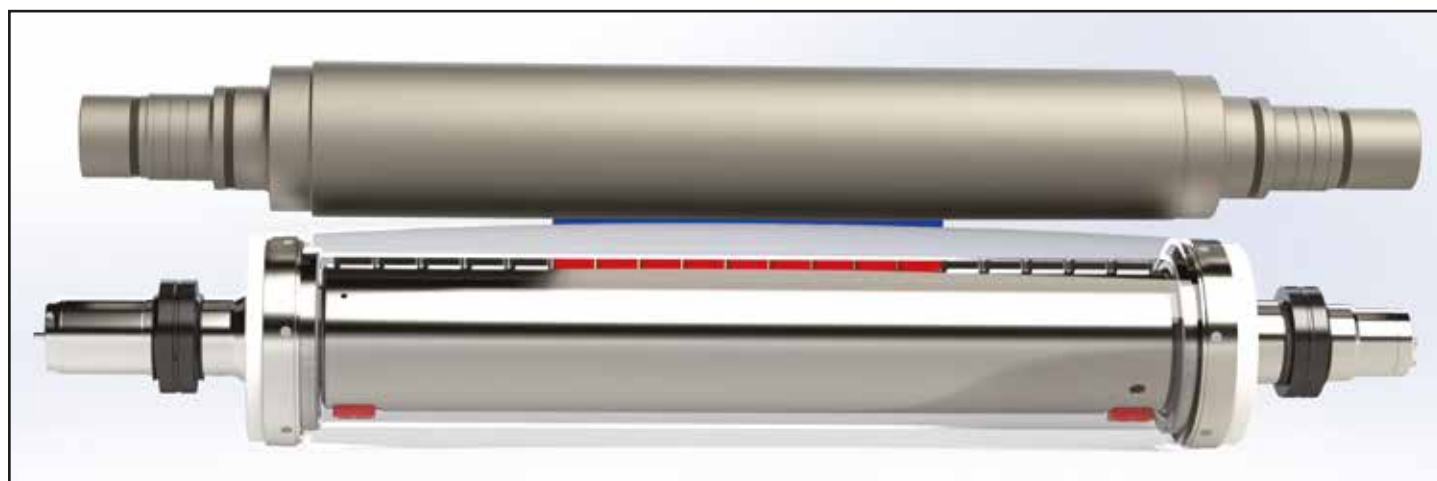
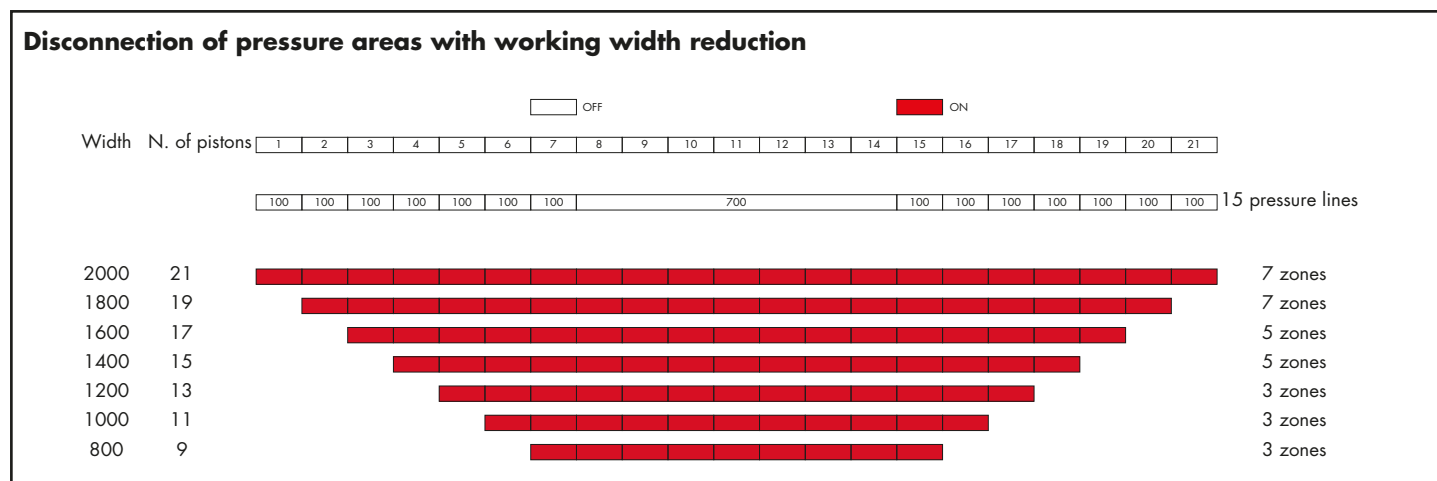

Since many years there are only two technical solutions on the markets to face the problem of the deflection of rolls under pressure: First, a system with only one single pressure chamber - either modified in trying to compensate zone related by using inner counter pressure loads or not. This technology is known as S-Roll system. Second, our famous, revolutionary Nipco™ system consisting of many pressure pistons across the width.

The characteristics of the S-Roll system are a steel tube which rotates around a fixed axle. The annular gap is separated by seals into two semicircular chambers. The chamber facing the nip is pressured by hydraulic oil. Thus an oil pressure is generated, that stands in a linear ratio to the outer production required hydraulic cylinder forces. This means that there is always an external hydraulic system required for the requested line pressure and with the inner semicircular chamber deflection is compensated by a second hydraulic pressure system.

Each variation of outer pressure setting requires a deflection compensating force setting inside the semicircular chamber. So this system always needs a steel tube closing the deflection compensating system. All covers available whether Thermoplast or Duroplast have to be shrunk on this steel tube respectively coated directly to this steel tube.

In comparison, the Nipco™ system is a self loading system. Whenever a flexible tube is turned around like GTP6 sleeve GTD3 sleeve or paper/cotton sleeve the pressure line is activated by pressure loading of the vertical moving Nipco™ pistons, piston by piston across the total width.



## OUR LATEST DEVELOPMENT

Individual pressure setting across the working width directly related to the demands of our customers' materials.

### Example of individual pressure setting showing one possible selection of zone arrangements according to customers' demands - piston by piston to be controlled individually, if requested!

Width N. of pistons 

1	2	3	4	5	6	7	8	9	10	11	12	13	14	15	16	17	18	19	20	21
---	---	---	---	---	---	---	---	---	----	----	----	----	----	----	----	----	----	----	----	----

100	100	100	100	100	100	100	100	700										100	100	100	100	100	100	100
-----	-----	-----	-----	-----	-----	-----	-----	-----	--	--	--	--	--	--	--	--	--	-----	-----	-----	-----	-----	-----	-----

 15 pressure lines  
Left Center Right

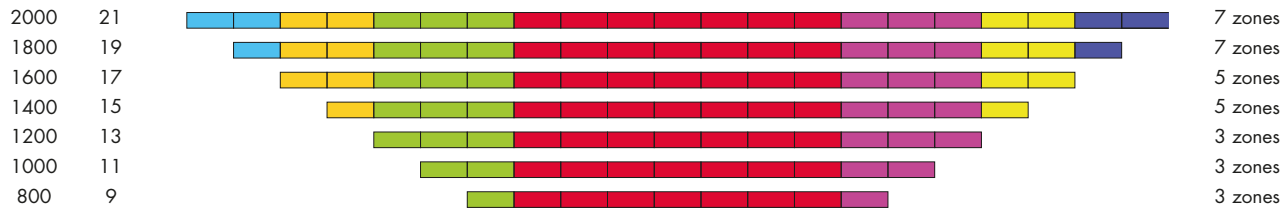

Example of pressure distribution:

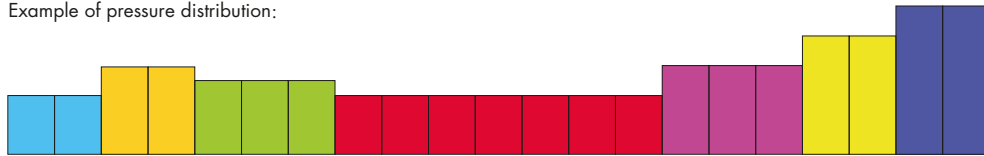

The Nipco™ HT system bowl is based on this fundamental difference: a flexible sleeve is turned around and a steel tube closing the pressure chamber is not required. Comparing the e-modul of a steel tube as in the S-Roll system and the e-modul of a flexible sleeve like **GTD3** or **GTP6** in our selfloading Nipco™ system it is obvious that flexibility up to factor 5 in a Nipco™ bowl system makes the difference, allowing zone controlled setting. The development of zone controlled pressure setting is our experienced answer to market demands. Thus Guarneri Technology is again setting standards in calender technology.

### Comparison, influence/efficiency from hydraulic piston at normalised load

— TopTec sleeve — GTP6 Sleeve — Steel tube

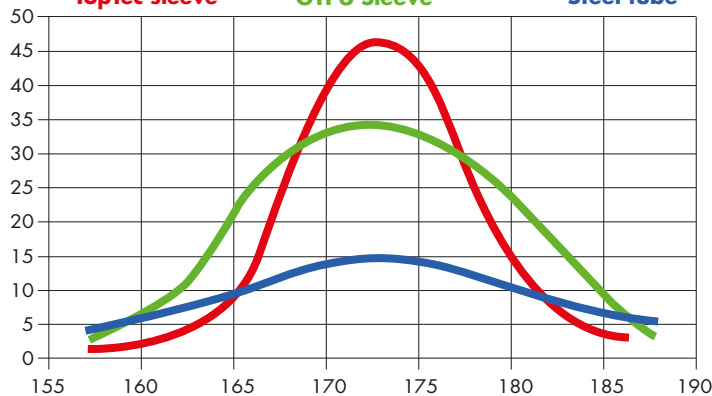

# Nipco™ Hot

## Nipco™ HOT Roll System

Especially for applications which requires higher roll surface temperatures on the roll surface, we developed the Nipco™ HOT roll system. Based on the proven Nipco™ principle, the deflection of the steel shell is compensated by hydrostatic pistons on the Nipco™ HOT roll. As a result, the linear forces can be set very precisely, even in hot applications and adapted to the conditions down to the micrometer range. Even if the requirements in the nip change due to a new product or a different fabric width, our customers are able to adapt the line force exactly to the new conditions.

The Nipco™ HOT roller system can be used up to a surface temperature of 300°C.

It is also possible to equip this roller system with a zone control according to the HT principle, which further improves the adjustment options, especially in the edge area.

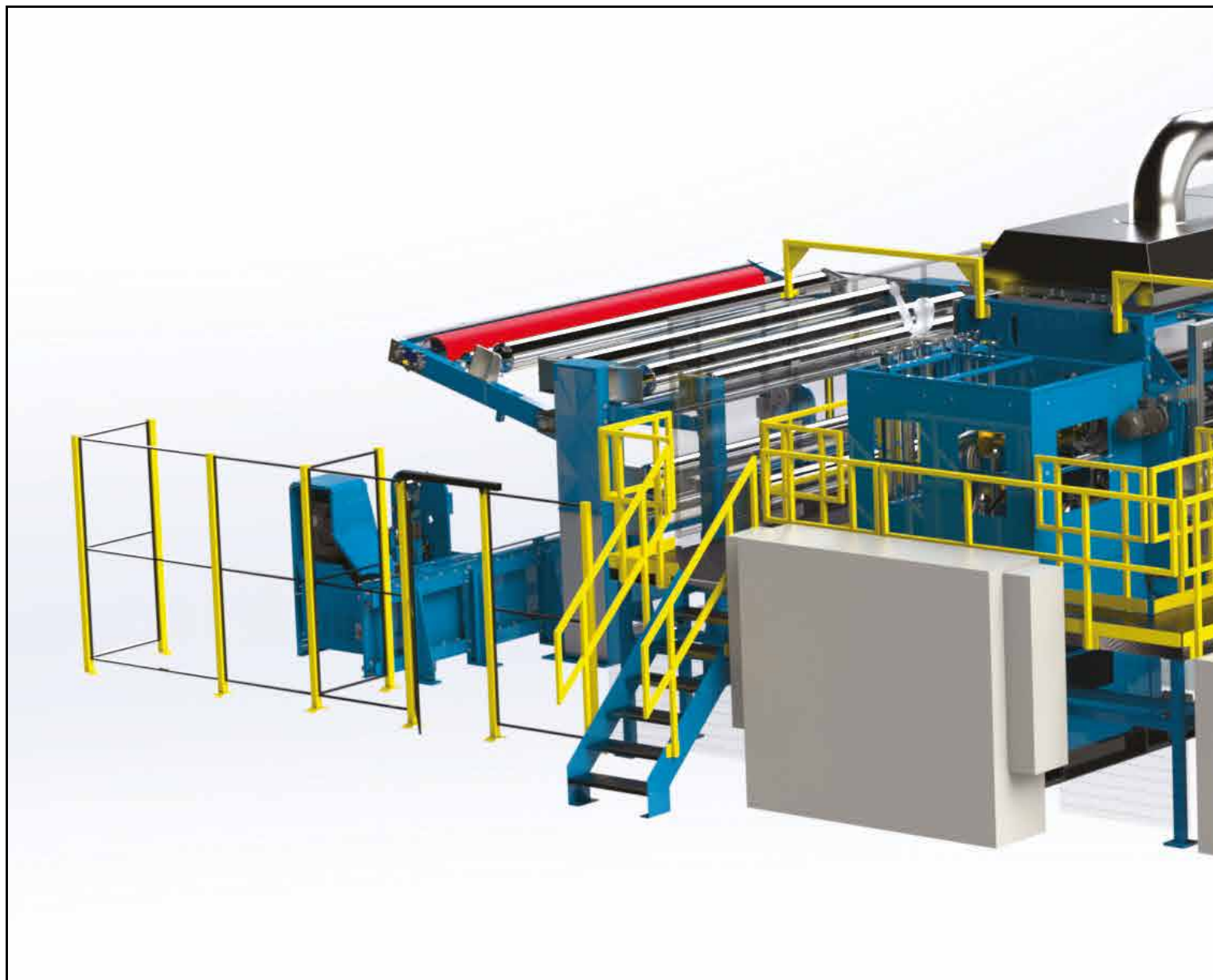

Nipco™ HOT calender

The independent pressure control zones are operated by special valves for diathermic oil up to 300°C complete with: opening regulation through electric or pneumatic system, position transducer and analogue pressure gauge. Valves are installed on the inlet oil pipes of the Nipco™ roller.

The system is operated by PLC.

Operator can select through the touch panel the working mode between linear pressure or differentiated pressure.

By linear pressure mode the Nipco™ Hot works against the steel roller using a single pressure value over the entire width while with differentiated pressure it is possible to have up to 8 different pressures each of them independently adjustable.

GT can supply various unwinding and winding units, from the simple unit consisting of motorized axial column with electro/pneumatic brake or with motorized units with the possibility to work by "A" frame or reels with self-supporting system and automatic centering system.

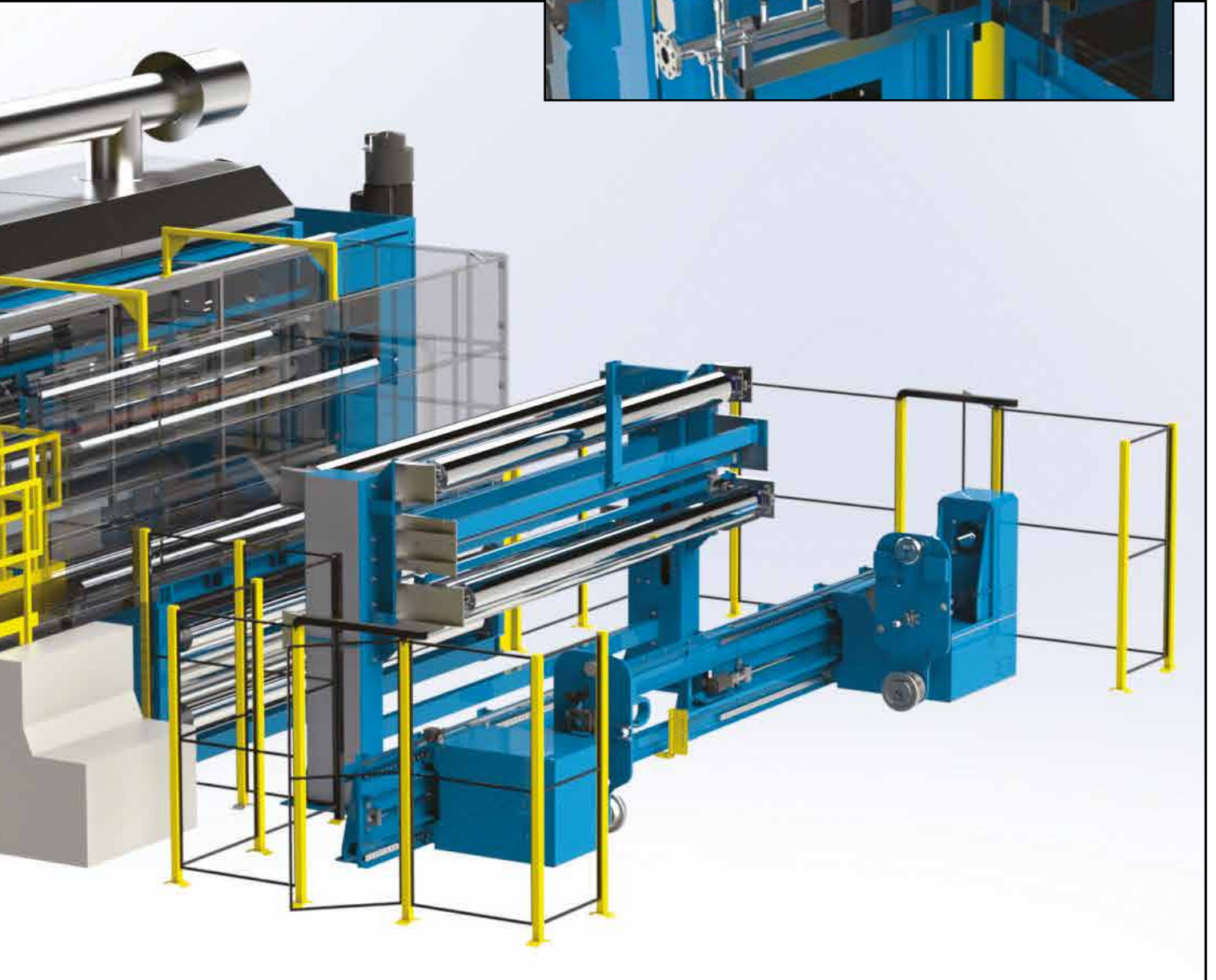

# Nipco™ AirHybrid Technology Dyeing Padder

## Advantages

- Nipco™ System based on **AirHybrid** Technology
- Homogenous press force distribution over entire material width
- Individual adjustable edge areas
- Precise adaption to material width
- Highly flexible sleeve system with different surface materials
- Cantilever execution with sleeve quick change system (GTQuick)
- Closed Loop – operation possible

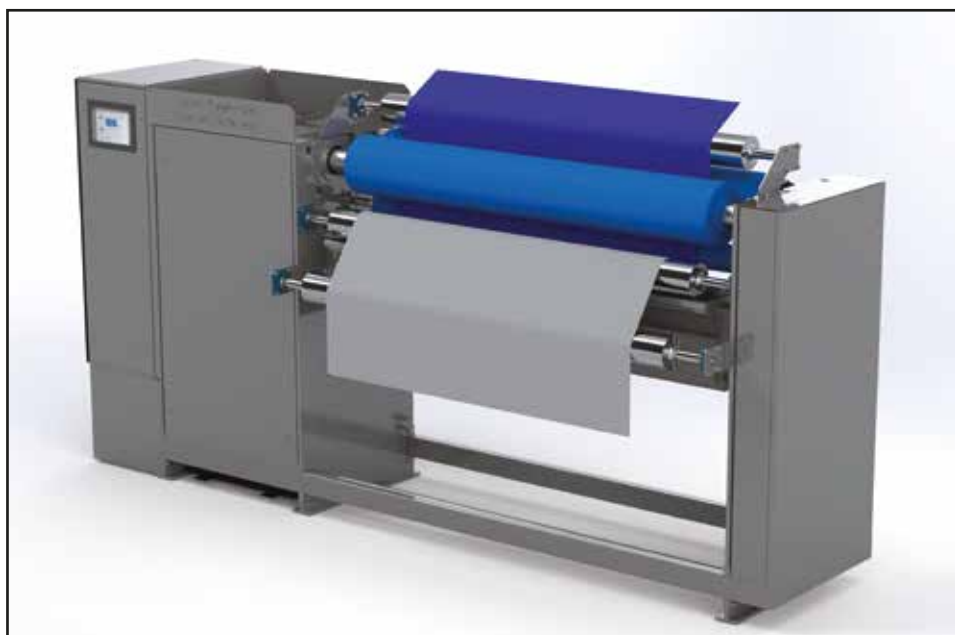

## Technical Data

Linear loads	10 - 50 N/mm
Roller width	1.000 - 4.000 mm
Roller diameter	265 / 300 mm

## Applications

A typical application for the Nipco™ AirHybrid roller is its use in a padding/dyeing station or during finishing and dewatering. Due to its flexibility, only one Nipco™ AirHybrid roller for padding or dyeing station is required. A conventional roller with different sleeve system acts as counter roller.

Compared to conventional padder stations with 2 bending compensating rollers, the service and maintenance costs are significantly reduced. Due to the cantilever version it is no longer necessary to remove the roller for a sleeve change. The sleeve quick-change system (GTQuick) allows to shorten set-up/downtime for cleaning and sleeve change to the minimum. The cleaning of the used sleeve can be done outside the machine and does not affect its availability. Today's increasing quality requirements demand technologies that guarantee maximum production reliability and individual adjustability. The Nipco™ AirHybrid roller meets these criteria in all areas and applications.

Their advantages are decisive for a reproducibly high product quality.

Chemically nothing changes from the traditional preparation of dyeing baths that are managed by the metering pump that mixes the auxiliaries and the color before entering the impregnation tank.

Here the fabric is squeezed from the small rubberized rollers immersed in the tank to facilitate the penetration of the dyeing bath inside the fibers that form the fabric, before passing between the squeezing cylinders of the padder.

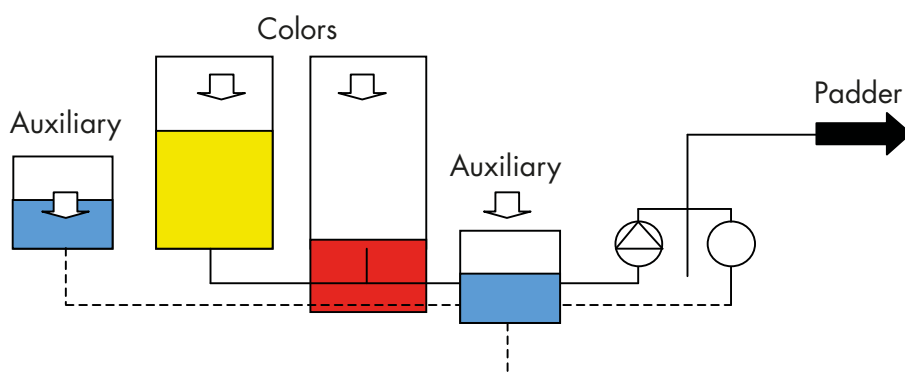



## Force distribution

This roller concept is characterized by its individually adjustable force distribution. The technology enables optimum pressure distribution regardless of the pressure level. The ideal shape pressure characteristic results in a uniform pressure over the width with perfectly reproducible results. Strips are eliminated by an advanced Nipco™ support system. The pressure characteristic of the roll can be adapted to the process requirements as needed. Edge areas can be actively loaded or unloaded.



If the process requires a different force distribution across the width, the support system can be controlled individually. This can also be done optionally in combination with a closed loop measuring system. The exact limitation of the working width also allows an adjustable transition of the edge areas at different material widths. A significant improvement in the process is the result.

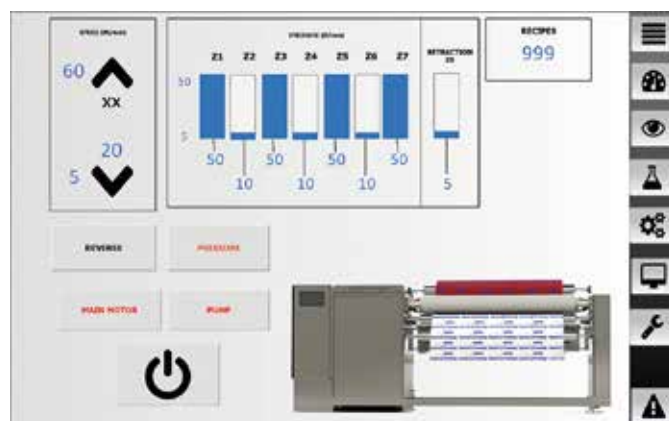
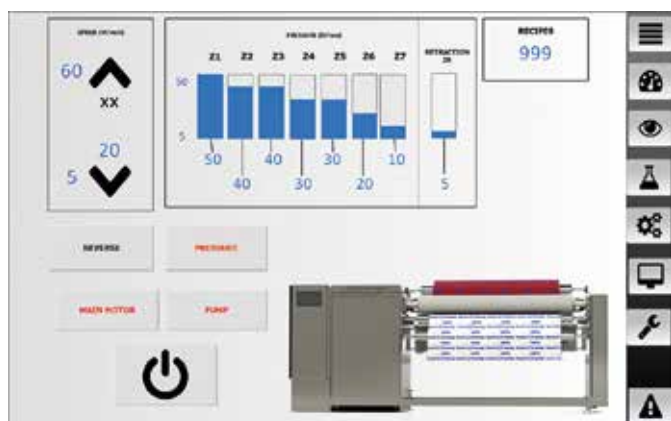
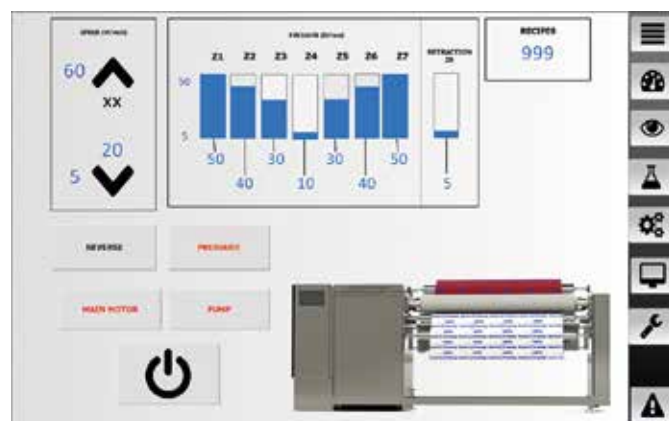
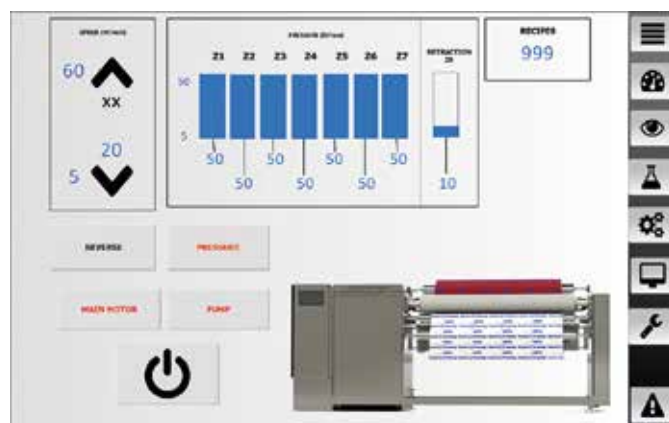
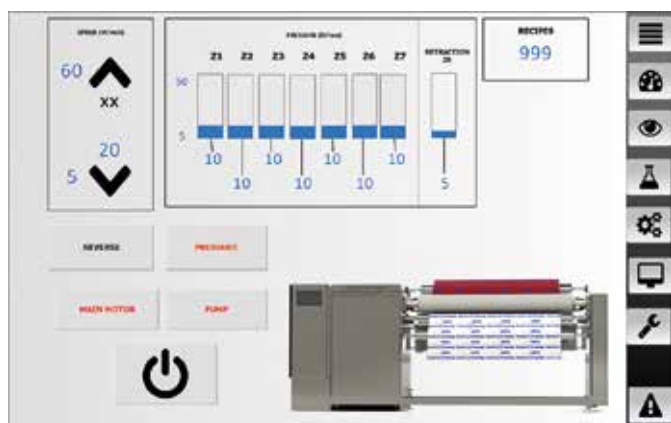

# Simili Calender

The right way to reach the best African Damask

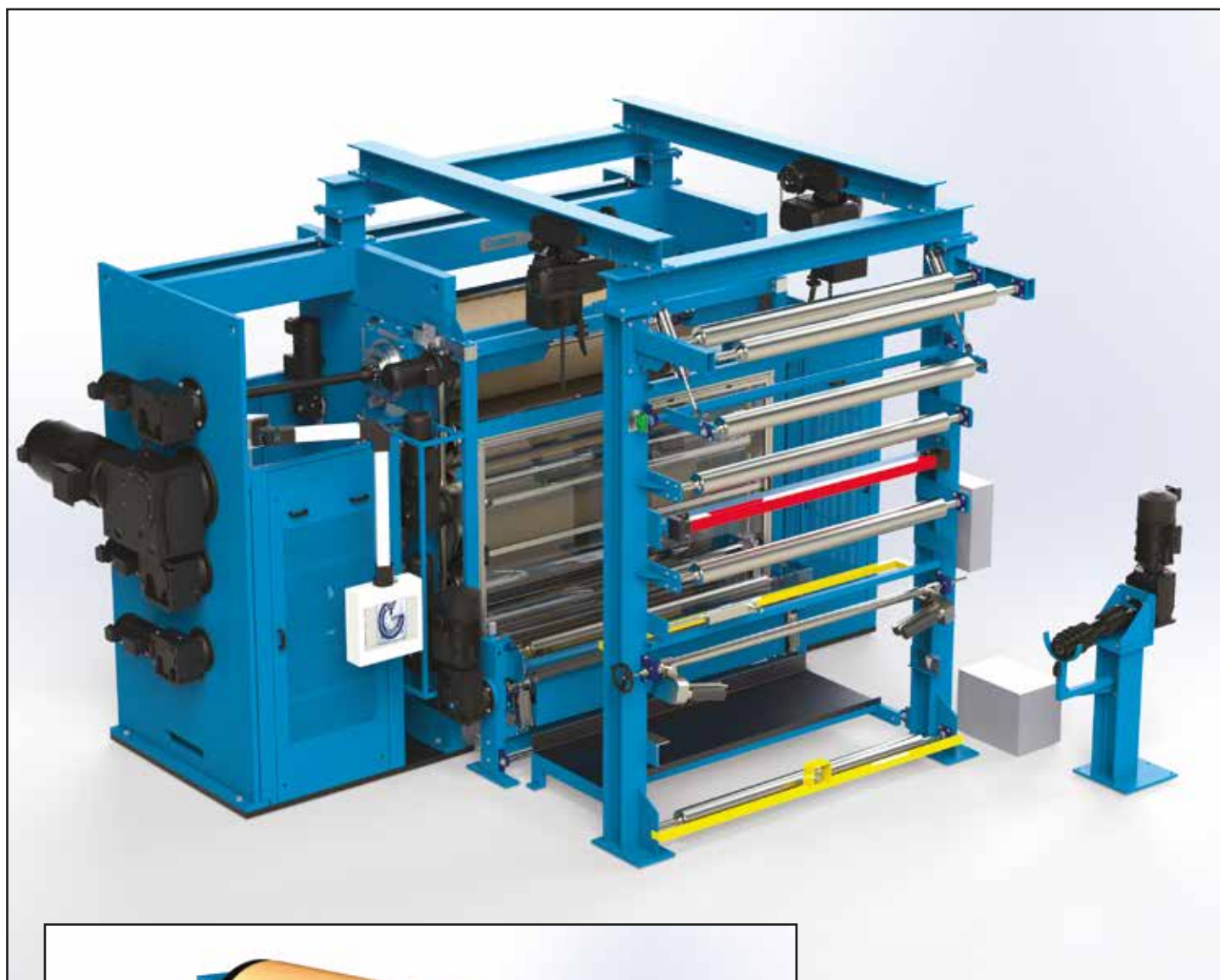

## TECHNICAL FEATURES

- Standard roller width 2.000 mm.
- Pressure up to 500 N/mm.
- Speed up to 60 mt/min.
- Temperature up to 320°C

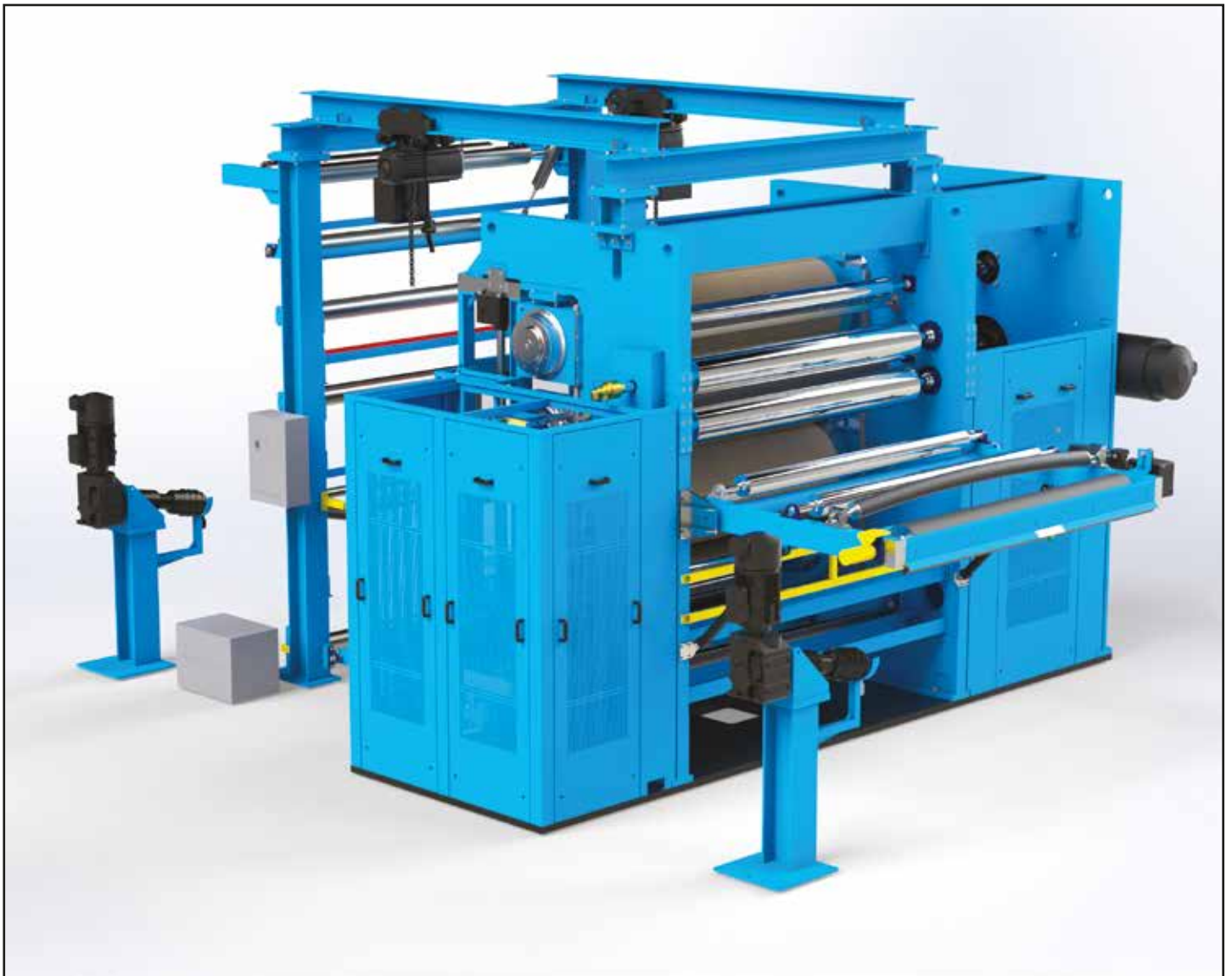

### **Bazin Riche is the African term used for Africa Damask**

It is the name for damask woven on Jacquard looms. Damascus means "colourful" and "sinuous".

The word Bazin comes from the Italian bombasin, which is derived from the Italian bambagia (cotton) and from the Latin bombyx (silk)

4 bowl Simili calender is the best solution for simili-mercerisation that reduces the swelling point of the cotton fibre becoming high permanent gloss for African damask and poplin material of pure cotton.

The rollers configuration of our Simili calender is composed by two steel rollers and two rollers cover by a blend of pure cotton and special fiber, named GTHT.

The GTHT cover grants excellent final result and and withstands the high temperatures of steel rollers.

Standard pressure line force up to 500 N/mm

# Embossing line for paper

Latest development by Guarneri Technology is the embossing calender for paper industry.

An important aspect of paper production is the embossing, i.e. the process by which the paper passes through a special polyamide GTP6 sleeve roller (Nipco™ or conventional) and a steel roller with an engraved surface.

The strength and technology typical of the GT embossing calender, dedicated to paper production, enhances the embossing process and guarantees results characterised by extreme engraving precision thanks to the Nipco™ roller that perfectly controls the pressure uniformity along the entire width of the rollers. It is possible to control not only the pressure range between the cylinders but also to control the pressure zone by zone with the new Zone Pressure Control HT.

Fully automated entry and exit frames, as well as loading and unloading of paper rolls.

## TECHNICAL FEATURES

- Pressure up to 300 N/mm.
- Speed up to 400 mt/min.
- Fast embossed sleeve change

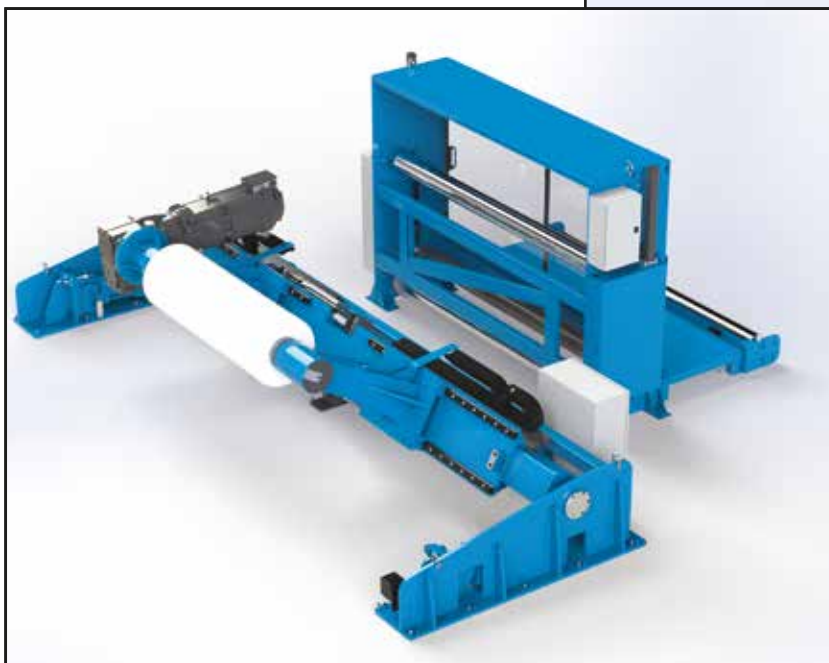



# Conventional Calenders



## Conventional Calender GTC260

Guarneri Technology 2 bowl conventional calender offers constant line force and a defined crown on the steel roller surface.

All our conventional calenders are equipped with Siemens S7 PLC and with 4 different softwares in order to obtain the best production results.

## Conventional Calender GTC360

Guarneri Technology 3 bowl conventional calender concept is the best-seller calender for different applications. With its different bowls configuration gives high performance where the deflection compensation control is not required.

## Conventional Calender GTC470

Guarneri Technology 4 bowl conventional calender is called UNIVERSAL calender due to the different possibilities of finishing on the fabric. With its 12 different bowls configuration is very well appreciate where the camber on the rollers are accepted.

## Conventional Calender GTC570

Guarneri Technology 5 bowl conventional calender is called THE SOFT MONSTER due to its dimensions and due to the degree of softness reached in its roller nips.



# Entry & Exit frames

Unwinder/winder are made of a tilting steel structure with two independent arms equipped with pneumatic expansion couplings or openable supports for square bars where the rolls of fabric/paper are positioned. The arms can be moved to the right/left allowing the installation of rolls of different widths. Furthermore in calendering mode they keep the material centered with the line. The tension in the material is controlled and guaranteed through a dancer and load cell which manage the gearmotor installed on one of the arms.

Unwinder/winder are made of a fixed steel structure where two independent shoulders are installed with a revolver system. Here two different pairs of openable supports for square bars or similar and a mechanical system which allows positioning a fabric trolley are fixed. The shoulders can be moved to the right/left allowing the installation of square bars or trolleys of different widths. Furthermore in calendering mode they keep the material centered with the line. The tension in the material is controlled and guaranteed through a dancer and load cell which manage the gear motor installed on one of the shoulders.

Unwinder/winder are made of a steel structure where the gearmotor or the electro-pneumatic brake with universal joint are positioned to be connected axially to the fabric trolley. The tension in the material is controlled and guaranteed through a dancer or load cell which manage the gear motor or the electro-pneumatic brake installed on the structure.

Unwinder/winder are made of a steel structure fixed on slides and equipped with two independent shoulders with gear motor and two supports with self-centering mandrel for tubes of different sizes. The shoulders can be moved to the right/left allowing the installation of pipes with different widths. Furthermore in calendering mode the whole structure is moved to keep the material centered with the line. The tension in the material is controlled and guaranteed through a dancer and load cell which manage the gear motor installed on one of the shoulders.



# Covers and Sleeves

## Wide range of covers and sleeves

The wide range of covers and sleeves, allows us to choose the best solution for our customers and fabric types to process.



### **Cotton Cover**

GT cotton cover is made by 100% Egyptian long fiber natural cotton.

Cotton threads are oriented circumferentially around the bowl giving far greater strength to the cover and also a softer feel to the fabric. High performance in terms of resilience, heat resistance and lifetime of the fibres. Small marks and scratches can be removed by the ironing process.

### **GTP6 Polyamide Sleeve**

The main characteristics of the thermoplastic GTP6 polyamide sleeve are its high elasticity and resilience.

Our sleeves are produced using a centrifugal process to ensure perfect homogeneity of the material.

It largely resists against seams and fabric selvages.

Maintenance through the ironing process is quick and easy.

Fast and easy replacement of the sleeve using special tools.



### **GT High Temperature Cover**

This cover uses a special formulation between cotton and synthetic fibres, prepared in a particular way.

One of the many advantages of using GTHT cover is that it is able to reach a surface temperature 250°C against the steel roller with max temperature of 400°C.

### **GTD3 Sleeve FullFlex shell system**

Different applications require harder Nip conditions than a standard polyamide shell system can deliver. The FullFlex shell system combined with a composite cover was specially developed for these purposes. Compared to polyamide, the glass fiber reinforced shell has a higher modulus of elasticity and can operate with higher line loads. As a result, the forces in the nip can be better influenced at specific points, while the elasticity of the shell system is retained. In addition, higher surface temperatures are possible compared to polyamide. With different fabric materials it is possible to save some passes through the calender and reduce production costs and time. This type of shell comes standard with a fiber-reinforced cover system, but also different rubber covers for e.g. embossing applications are possible.

Our FullFlex system has proven itself over the past decades in numerous applications inside and outside the textile industry.



**Other types of covers are available such as woollenpaper, rubber and GT2 Bi-Component (polyamide and rubber)**

# Heating Systems



**GT offers different heating systems.**

**These systems depend on Customer's demand**

## **Electro Hot Water**

EHW heating system which acts as an immersion heater, using distilled water to generate the steam which is pressurised in the steam chamber, gives a very even spread of heat across working width of the bowl width with a temperature accuracy of  $\pm 1,5^{\circ}\text{C}$ .

**Your advantage:** high temperature accuracy, cleanliness, space-saving and maintenance-free.

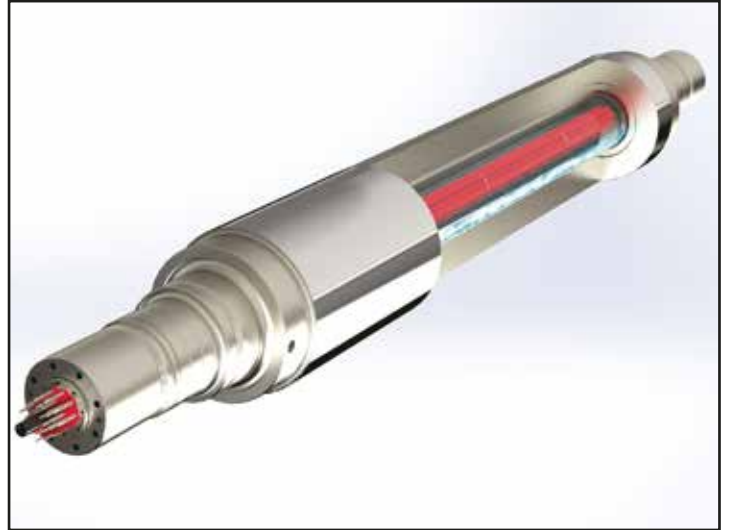

## **Peripheral drilling system**

Peripheral drilling allows the diathermic oil to run very close to the surface of the roller, considerably decreasing heating and cooling times, not only that, but the diathermic oil circulates in the peripheral drilling from right to left and vice-versa, ensuring perfect temperature uniformity and considerable energy savings.

**Your advantage:** the immediate reaction on decreased fall of temperature is guaranteed.

## **Thermal Oil Heating**

A widely used system in which diathermic oil flows through the single chamber of the central bore of the roller.

**Your advantage:** reachable temperature  $250^{\circ}\text{C}$  or above on request. Temperature accuracy  $\pm 1.5^{\circ}\text{C}$ .

Fast heating and cooling times if the secondary unit is equipped with a cooling system.



## Complete Technological Upgrade for Calenders

The **Guarneri ReLife** program is designed to restore your calender to performance levels comparable to those of the latest generation machines through a complete upgrade of electrical, hydraulic and control systems.

The upgrade includes the integration of a new electrical control cabinet with PLC and HMI interface, the implementation of advanced digital control logic, and the installation of a high-efficiency hydraulic power unit.

Thanks to the revision of control circuits and the optimization of pressure, temperature and process management parameters, the machine achieves higher levels of precision, operational stability and production reliability.

**The result is a more efficient, safer calender ready to meet the requirements of modern industry.**

### Economic Benefits

- Optimization of investment through the technological upgrade of the existing calender
- Reduction of maintenance costs in the medium and long term
- Reduced downtime thanks to the reliability of the newly installed systems
- Greater production continuity through digital process control
- Fast implementation times without the need to replace the entire machine
- Increased value of the existing machine, extending its operational life cycle
- Reduced maintenance times thanks to immediate availability of key spare parts

### Technology and Performance - Improved Operational Performance

- New electrical cabinet with latest-generation PLC and intuitive HMI interface
- High-efficiency hydraulic power unit with dedicated electronic control
- Higher precision and operational stability thanks to proportional valves for optimal pressure management
- Automatic control of pressure, temperature and production recipes
- Reduced machine setup and start-up times
- High repeatability of production parameters

### Technological Modernization

The **ReLife** program modernizes your calender with the latest digital technologies, making it ready for integration into modern manufacturing systems.

- Full Industry 4.0 readiness
- Interconnection with company management software systems
- Integrated remote assistance and remote diagnostics
- Data acquisition and process parameter analysis
- Advanced predictive maintenance functions
- Compliance with CE safety standards
- Upgradable firmware for future expansions and optimizations

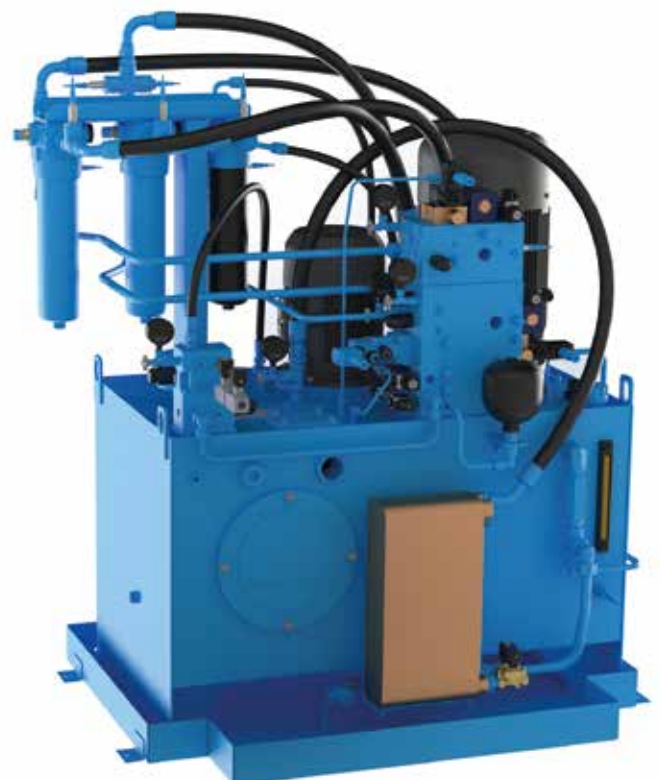

## Nipco™ Rolls

### Complete Overhaul of Nipco™ Rolls

Thanks to its ownership of the Nipco™ technology, Guarneri is able to provide a complete revamping service for Nipco™ rolls, ensuring highly qualified interventions fully compliant with the original technical specifications.

Direct availability of all original components and spare parts allows complete roll overhauls, restoring performance, reliability and operational precision.

The revamping intervention includes inspection and restoration of the main functional elements of the roll, ensuring maximum efficiency, operational continuity and long service life.

### Advantages

- Complete revamping of Nipco™ rolls according to original technical specifications
- Direct availability of all spare parts and components
- Restoration of roll performance and reliability
- Increased operational lifetime and stability
- Interventions carried out by Nipco™ technology specialists

## GTP6 Polyamide Sleeves

Guarneri directly manufactures GTP6 polyamide sleeves used on Nipco™ rolls, ensuring high manufacturing quality, dimensional precision and full compatibility with different calender configurations.

Thanks to the experience gained over time and in-house sleeve production, we are able to supply spare parts for all calenders equipped with Nipco™ rolls installed from 1979 to the present day.

The availability of a wide range of diameters and heights also allows us to provide solutions compatible not only with Guarneri calenders, but also with calenders manufactured by other suppliers.

### Advantages

- Direct Guarneri production of GTP6 polyamide sleeves
- Spare parts availability for calenders installed from 1979 to today
- Wide range of diameters and heights available
- Compatibility with Guarneri calenders and machines from other manufacturers
- High component quality and precision
- Fast supply thanks to in-house production



# Spare parts



- Supply of original and genuine spare parts for Nipco™ calender for Textiles, Technical Textiles and Special Application
- Main spare parts for all type of Nipco™ calenders since 1973
- GTP6 polyamide sleeve for Nipco™ and conventional calenders
- All type of GDT3 Duroplast sleeves
- Cotton and woollen-paper rollers



# Service

- Dismantling, check and revision of all:
  - Nipco™ rollers
  - Nipco™ Tex rollers
  - Nipco™ print rollers
  - EcoNip rollers
  - S-Roll
  - Nipco™ Hydrein
- Nipco™ static and dynamic test
- Regrinding of all kind of textile rollers as rubber, cotton, woollenpaper, steel and polyamide
- Refilling of all type and sizes of cotton or woollenpaper rollers
- Modification of cotton or woollenpaper bowl to GTP6 polyamide roller
- Sleeves with all diameters and lengths
- Re-covering of existing rollers
- Complete overhaul of existing calenders with CE certification







A dedicated team for online service in real time, to give our best and prompt assistance.





**Guarneri Technology s.r.l.**  
21052 Busto Arsizio (VA) - ITALY  
Via Stefano Ferrario, 4b  
Tel. ++39 0331 341897  
[www.guarneri-technology.com](http://www.guarneri-technology.com)

-  Guarneri Technology
-  [guarneri\\_technology\\_srl](https://www.instagram.com/guarneri_technology_srl)
-  Guarneri Technology
-  Guarneri Technology s.r.l.