

Guarneri



Technology™

NIPCO™ Technology

Nipco history

Zurich, 1971

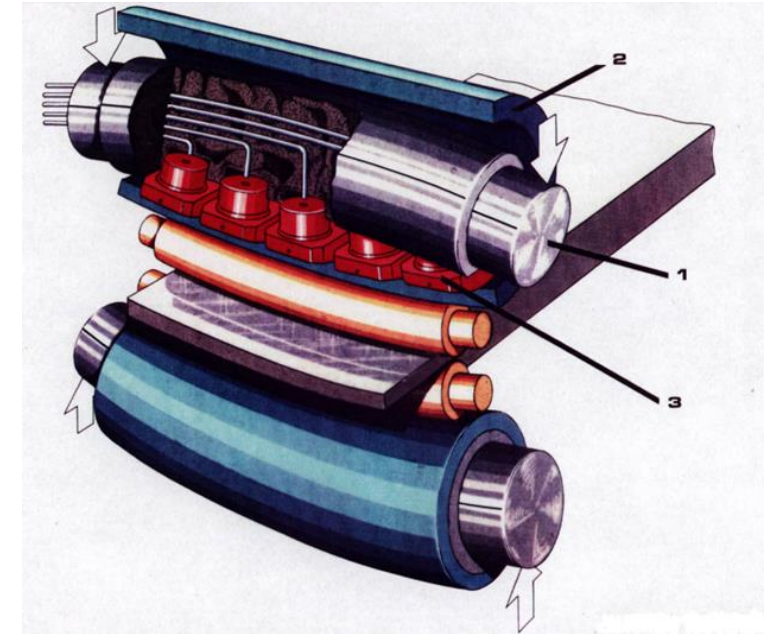
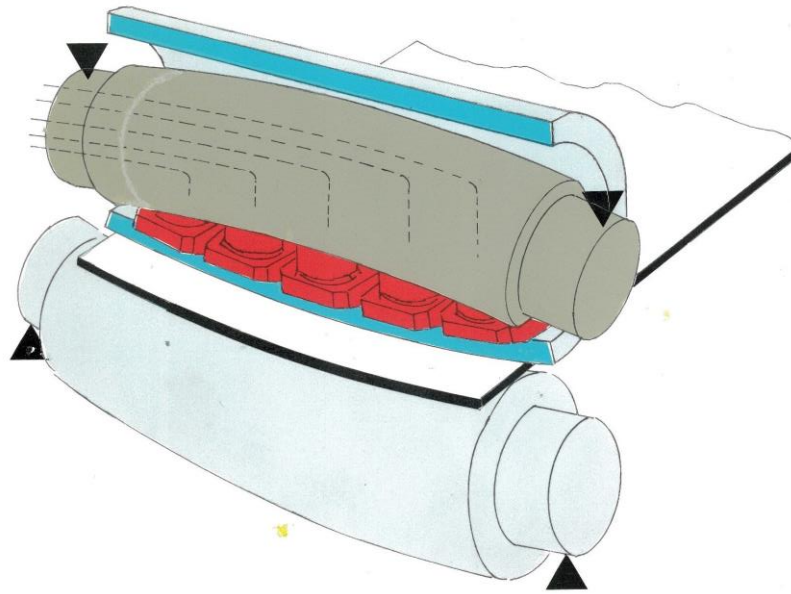
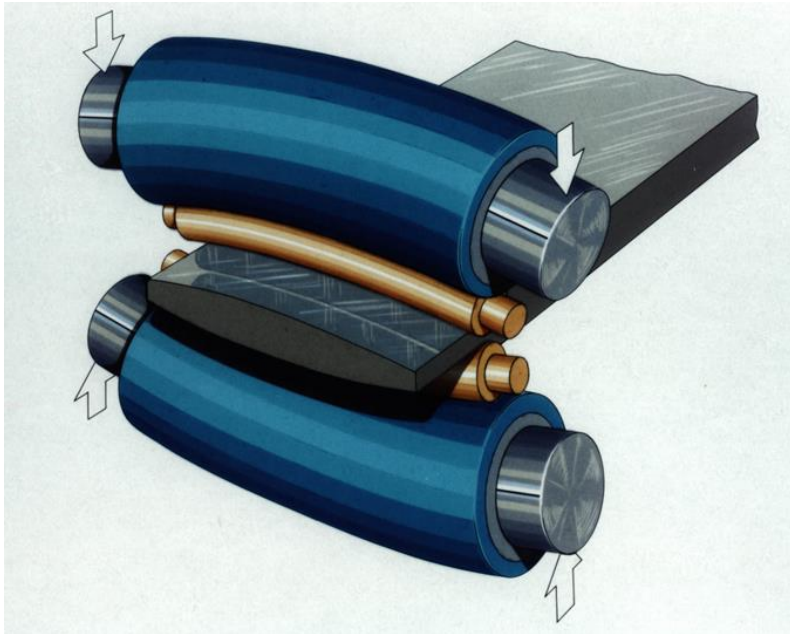

Nipco system

How does it work?

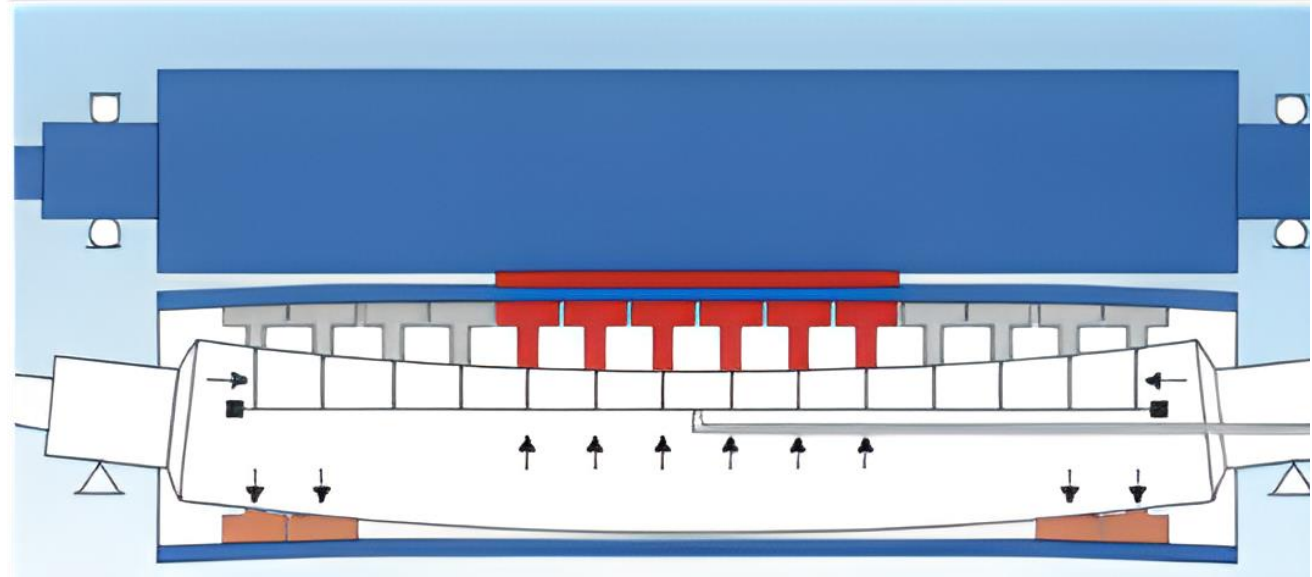
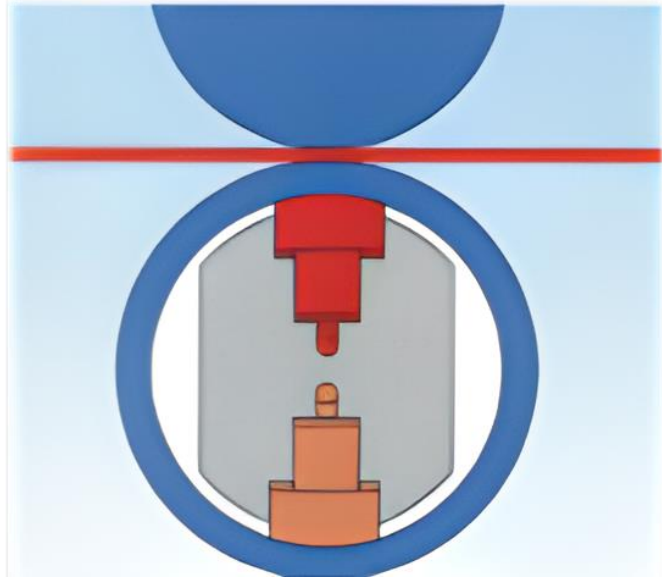

Nipco system Pistons

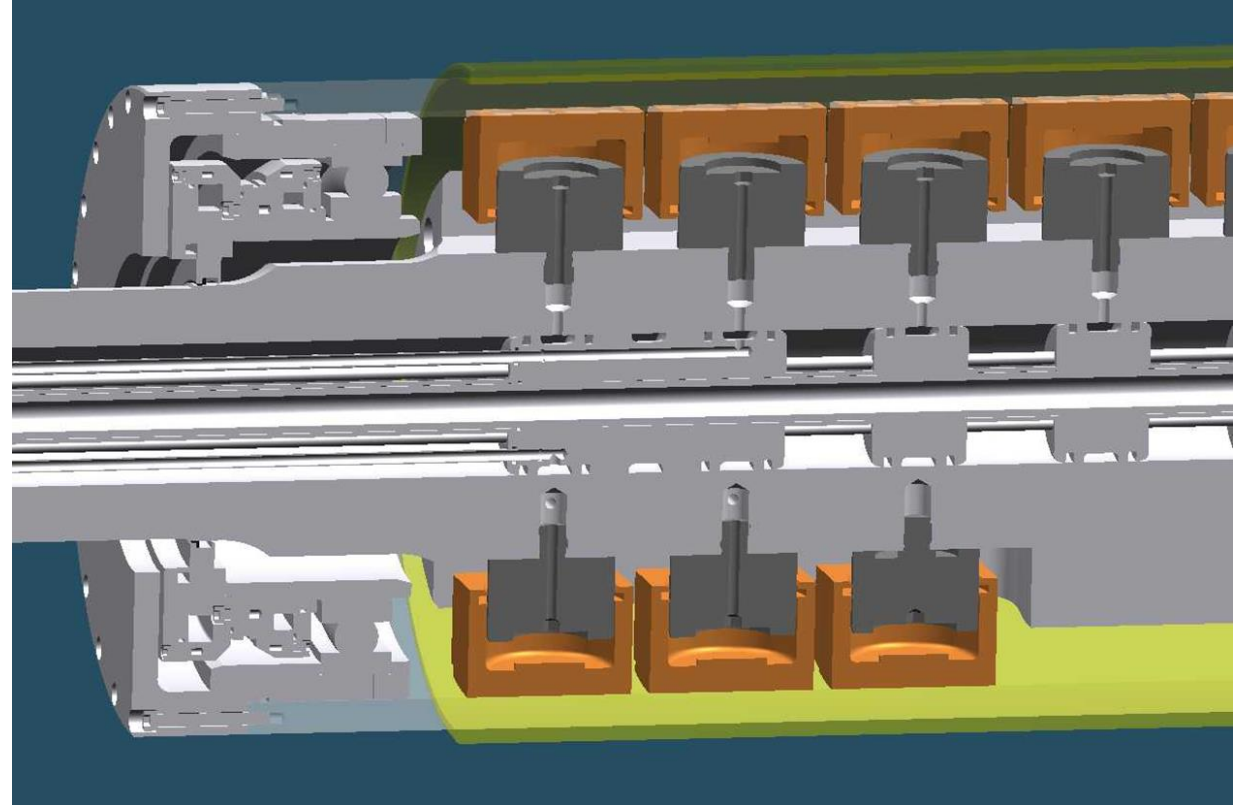
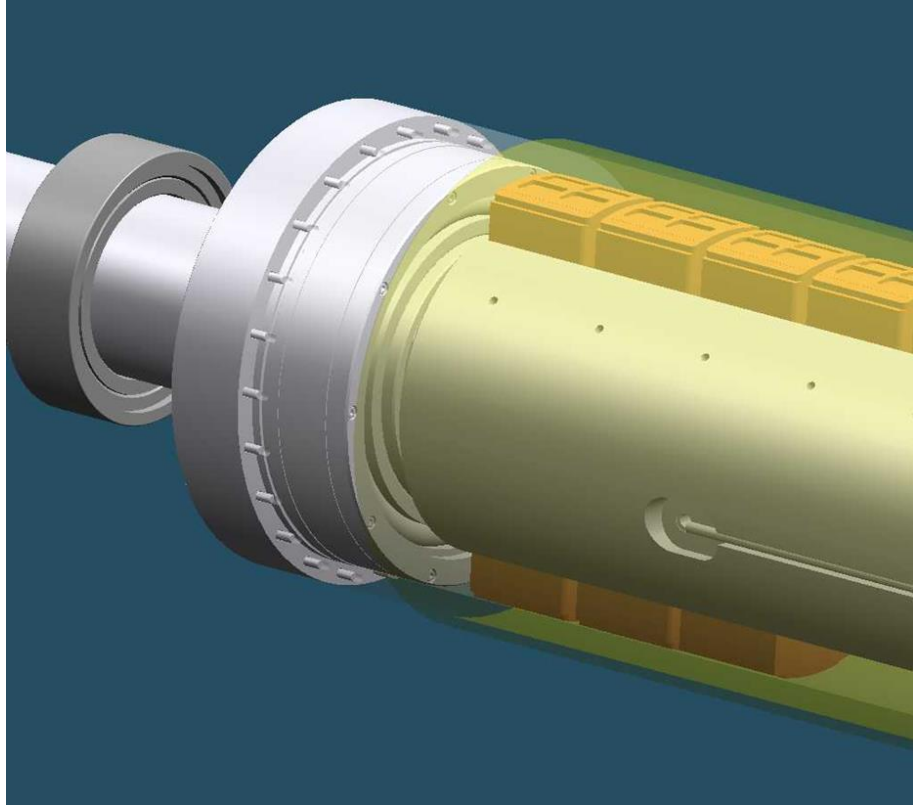

Nipco system Pistons

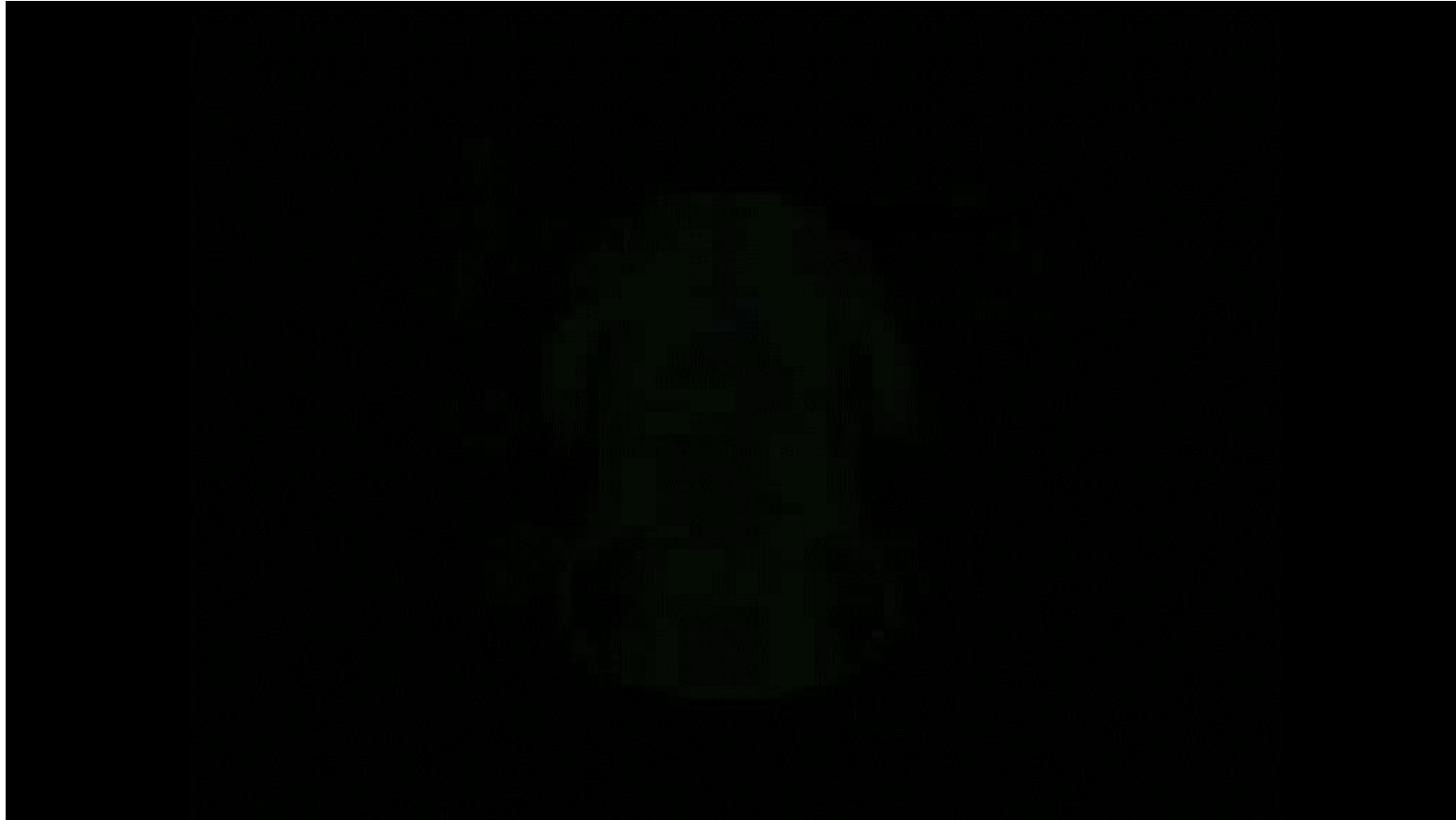

Why Nipco?

Perfect uniformity

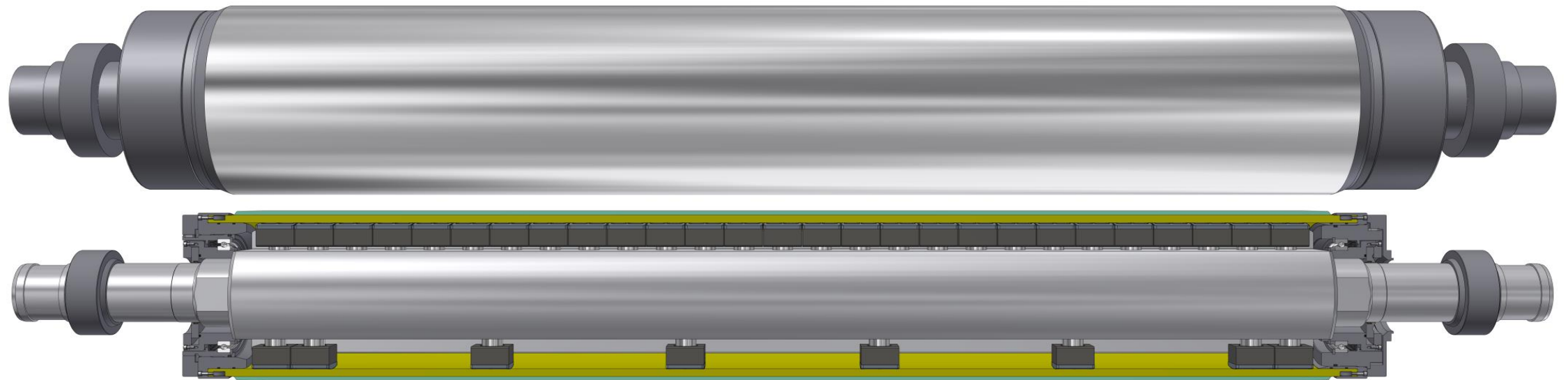

Why Nipco? Perfect uniformity

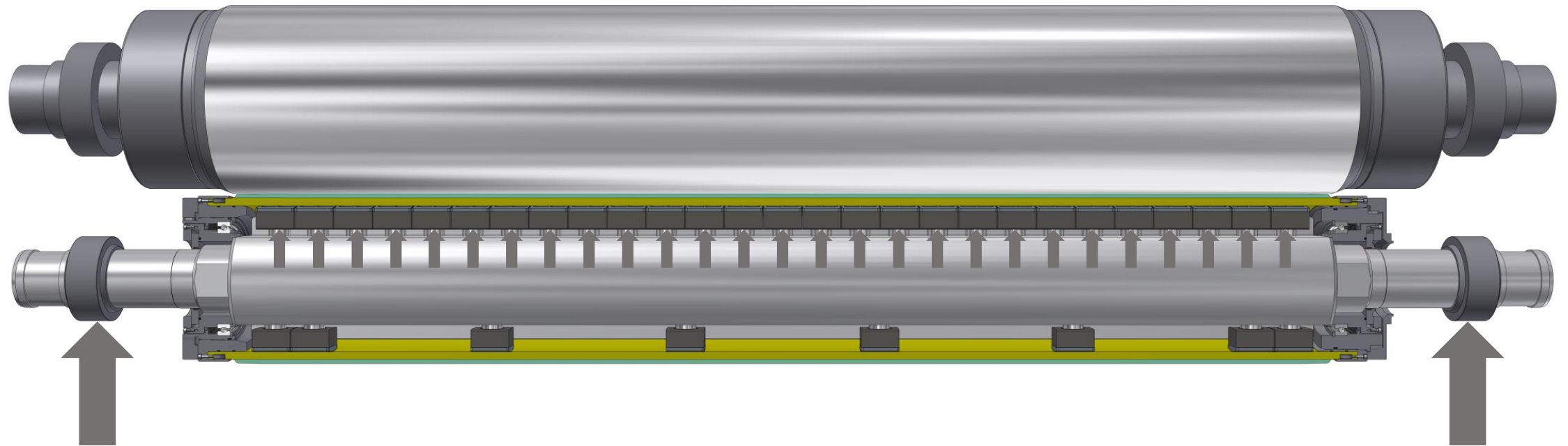

Why Nipco?

Widht adjustment

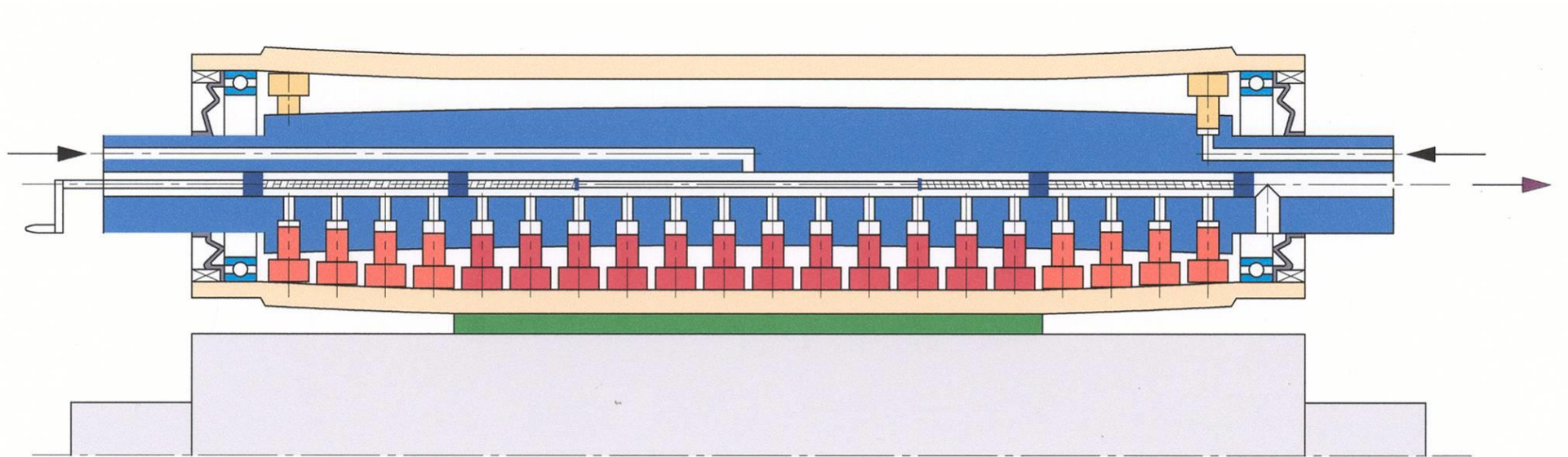

Why Nipco?

Multi area pressure

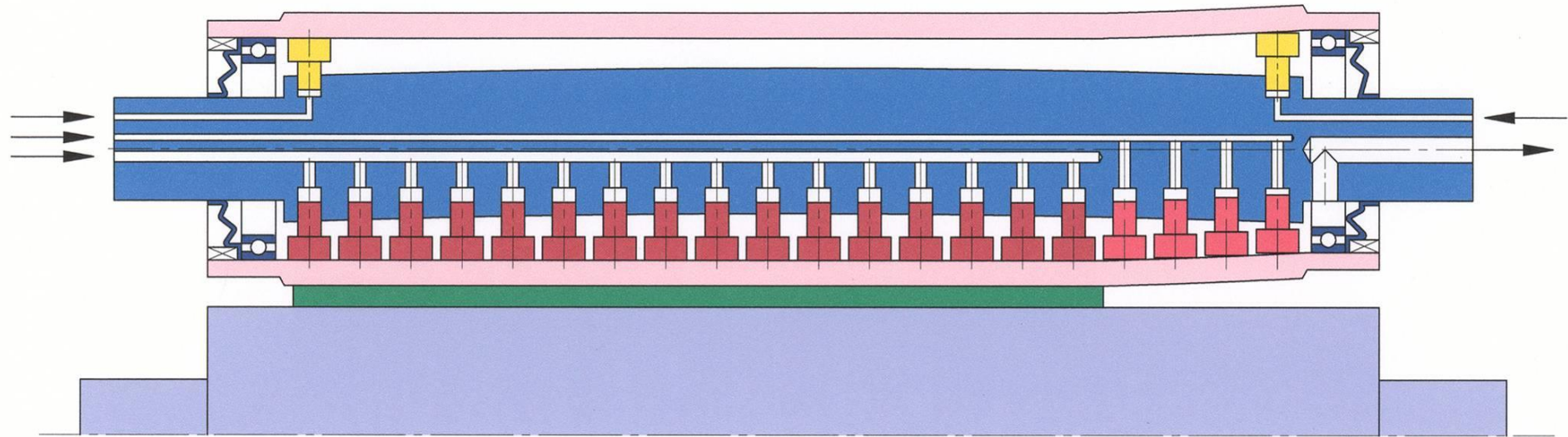

Why Nipco? Edges retraction



Why Nipco?

Wide choice of sleeves



FullFlex TT3

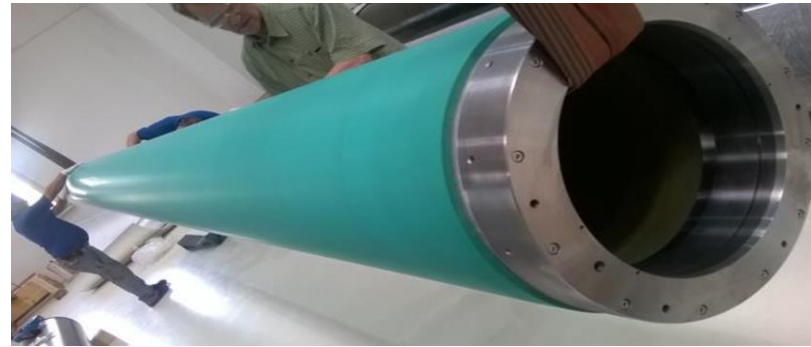

FullFlex



GTP6

Why Nipco?

Alternative heating system

- Electro Hot Water (EHW)
- Thermail Oil
- Gas

Nipco system

Electro hot water (EHW)

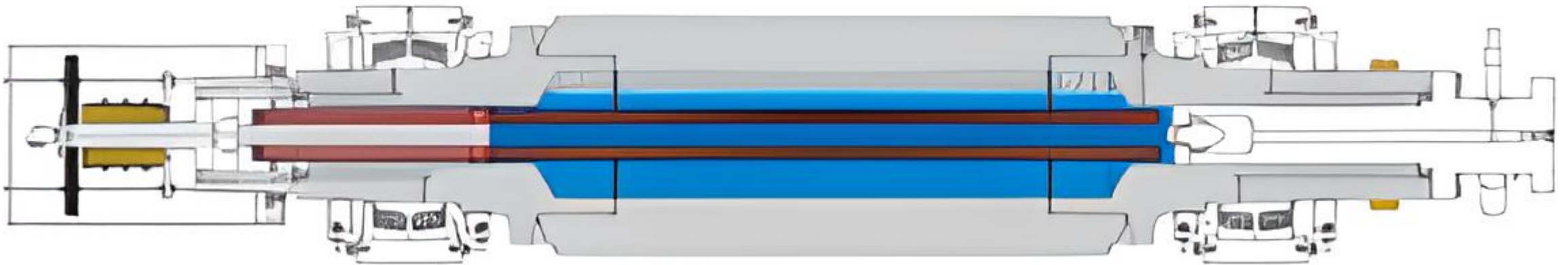

Nipco type Nipco I

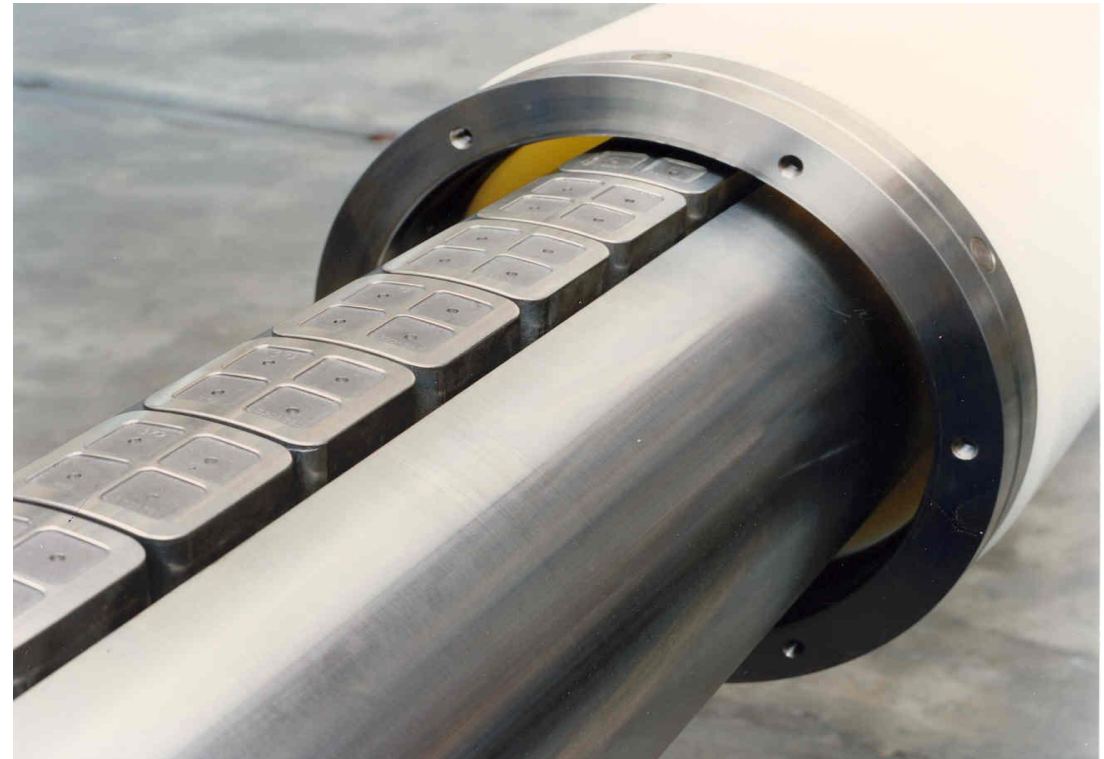
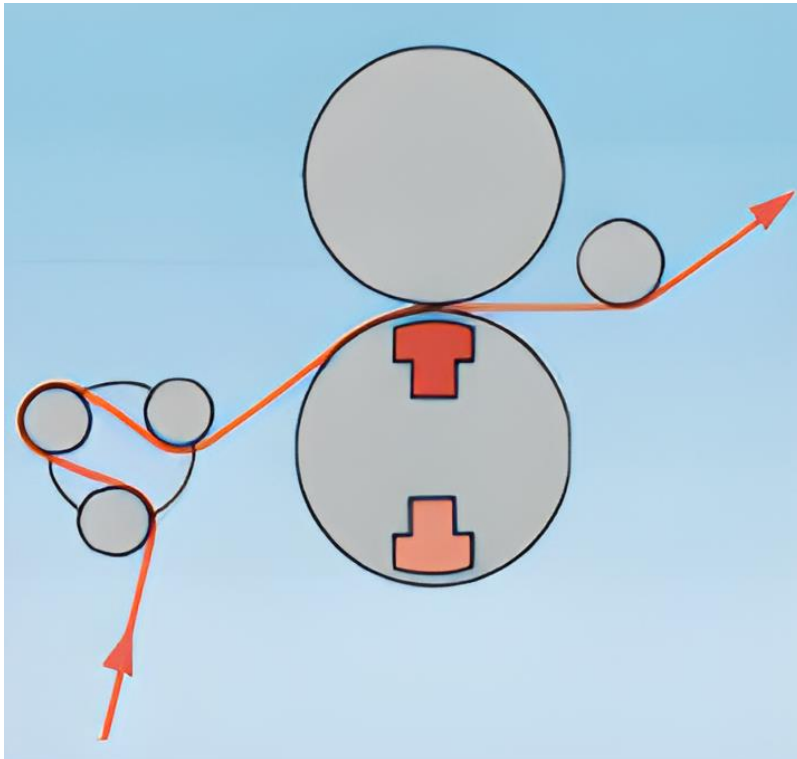

Nipco type Nipco Double I

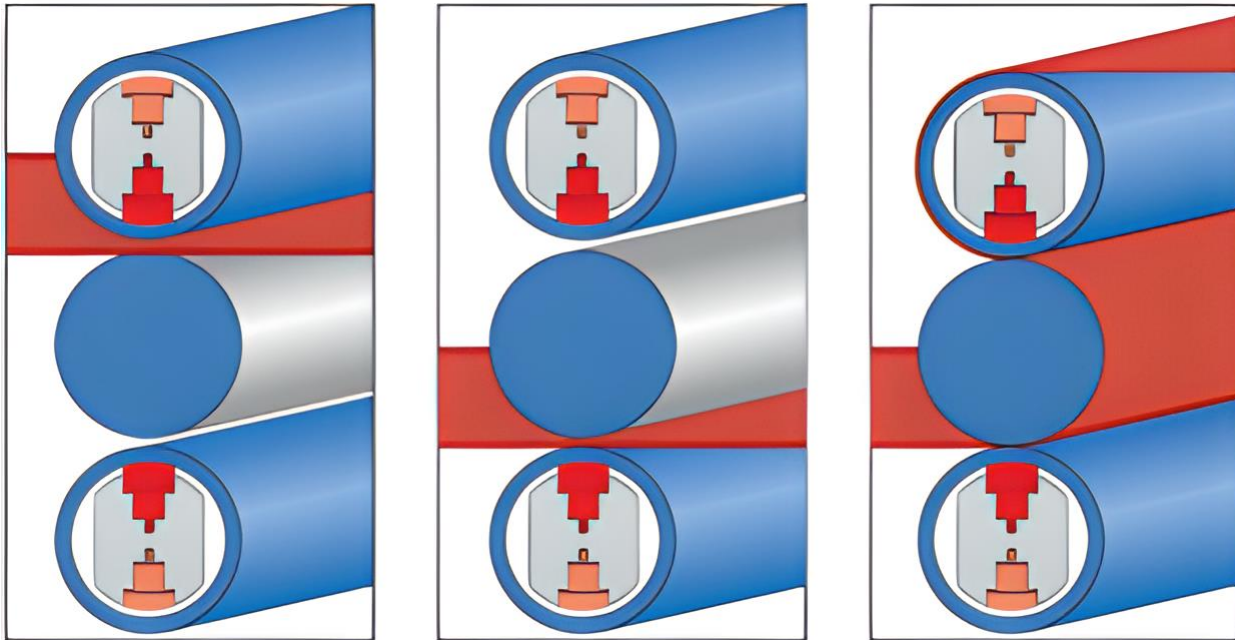

Nipco type

Nipco L

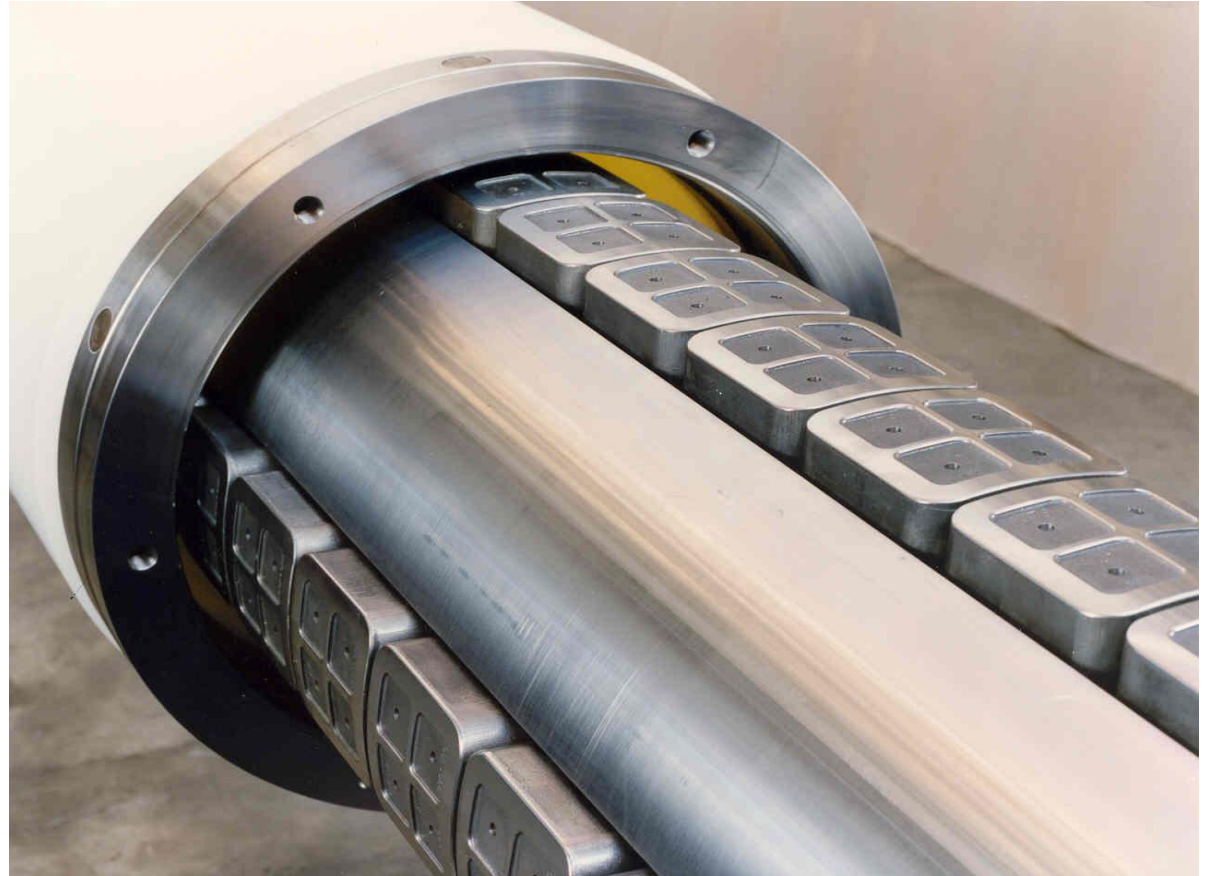
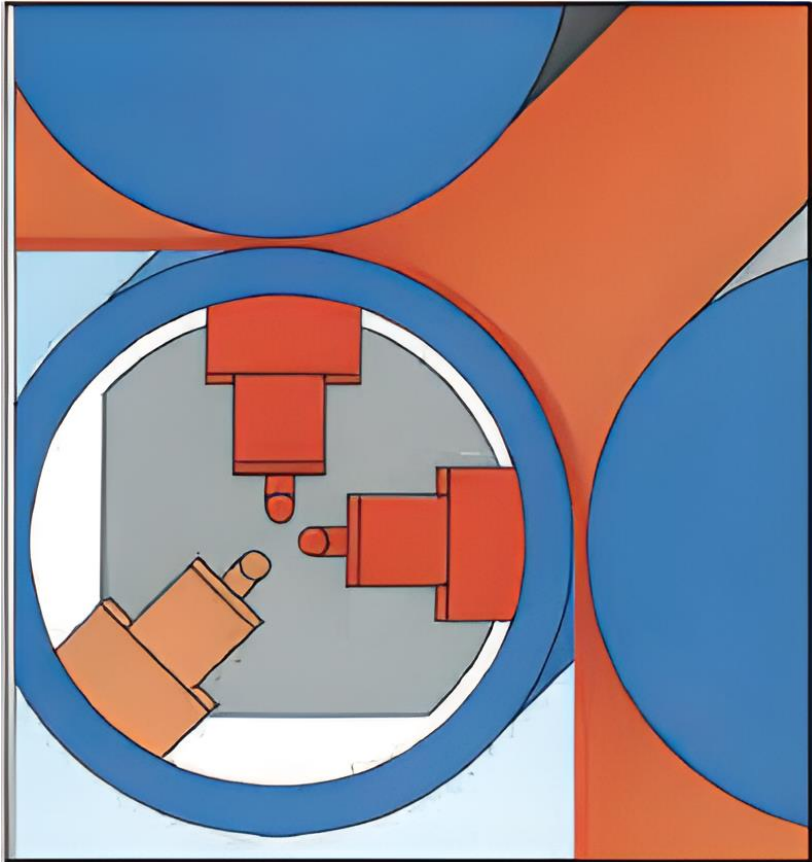

Nipco type Nipco Flex

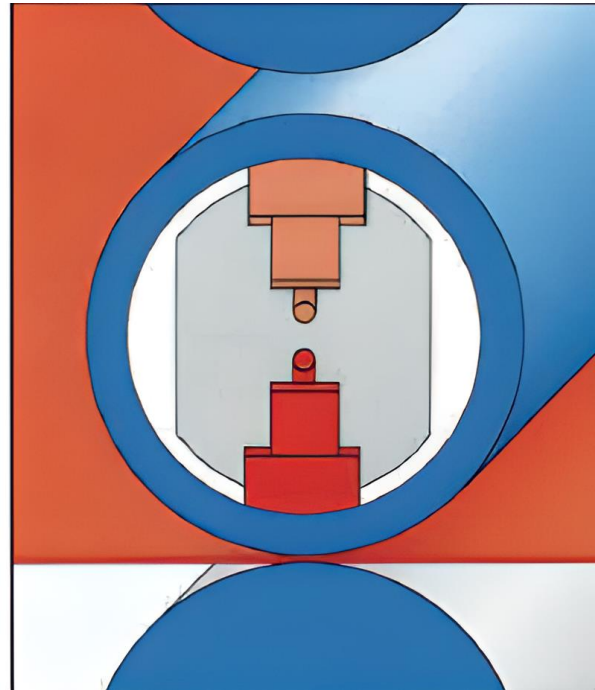
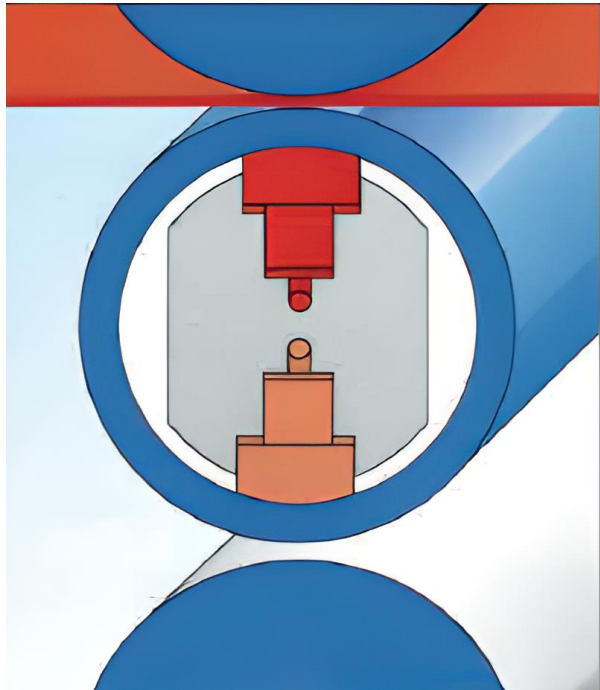

Nipco type

Nipco Embossing

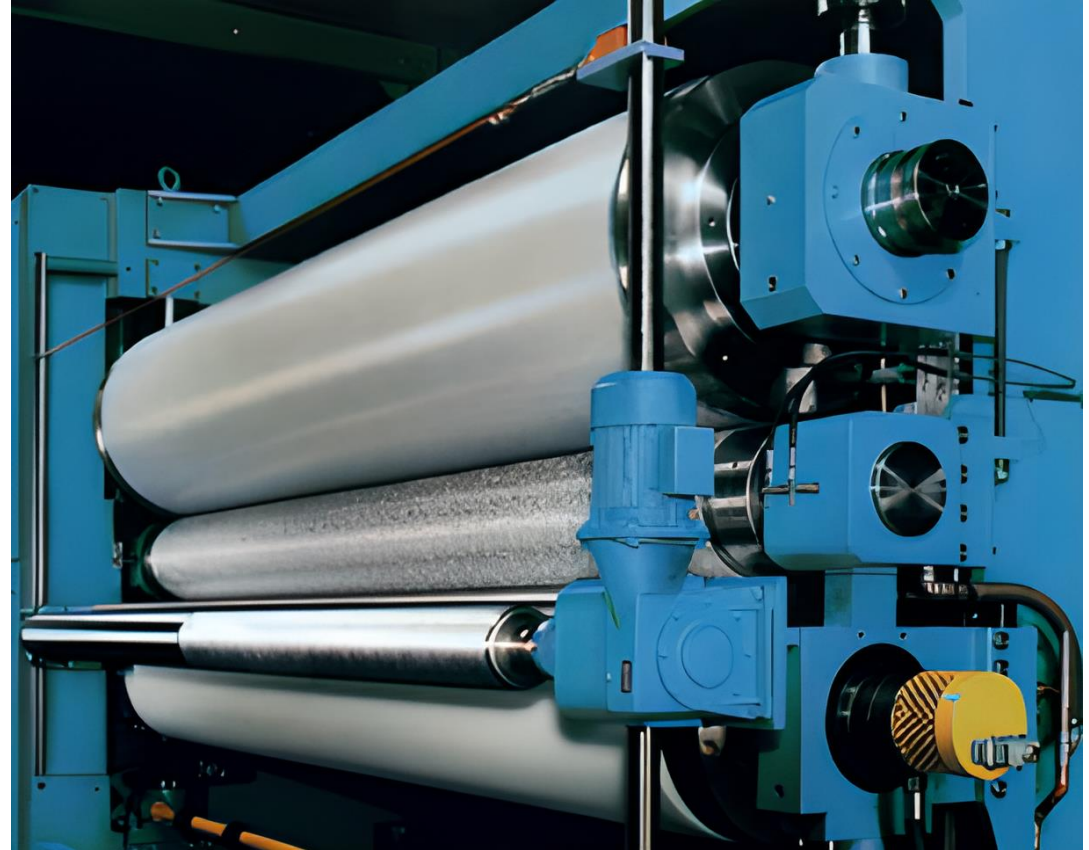
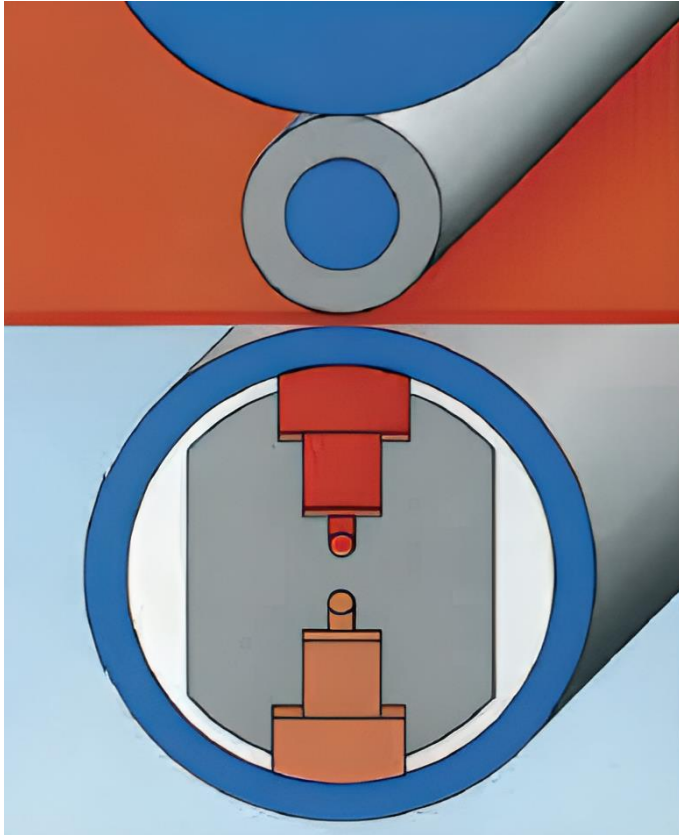

Nipco system

Nipco HT

Example of individual pressure setting showing one possible selection of zone arrangements according to customers' demands - piston by piston to be controlled individually, if requested!

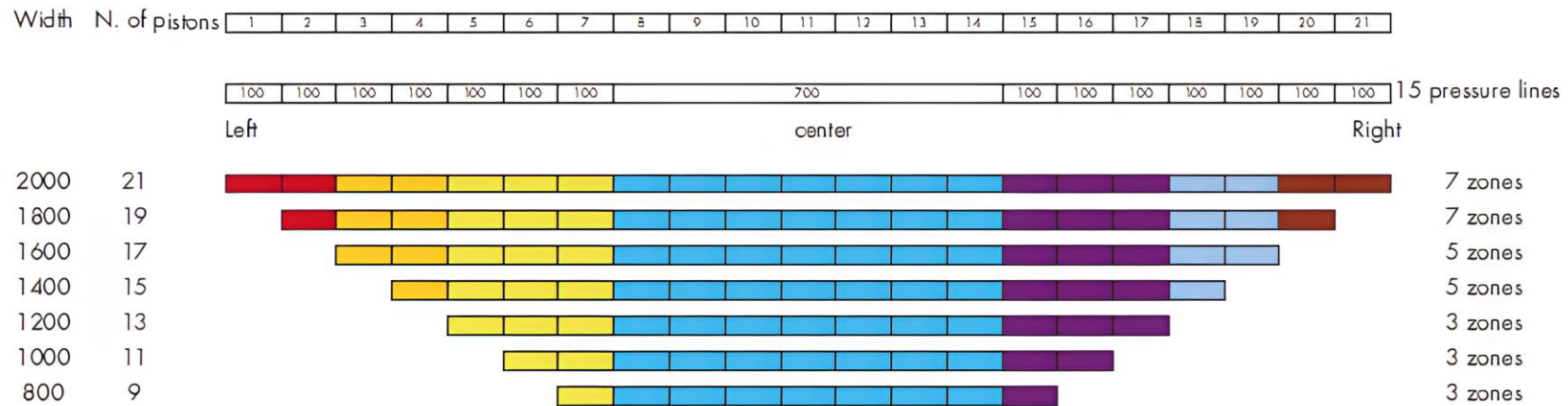

Example of pressure distribution:



Nipco HT

How to control air permeability: TexText

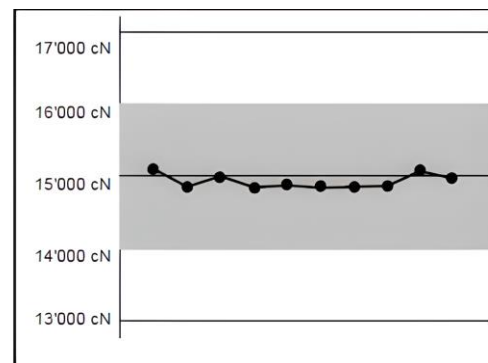
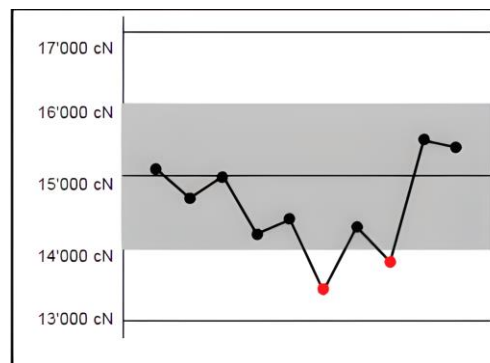
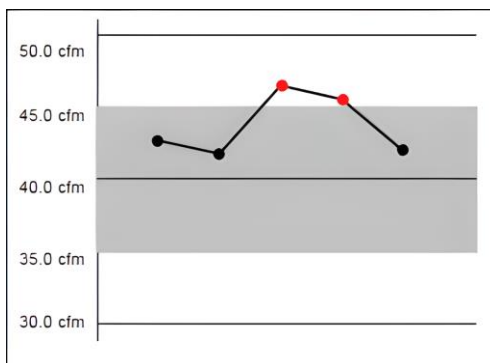
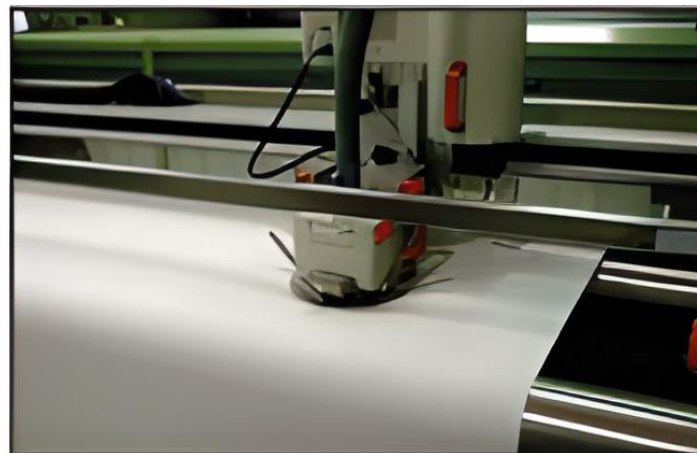
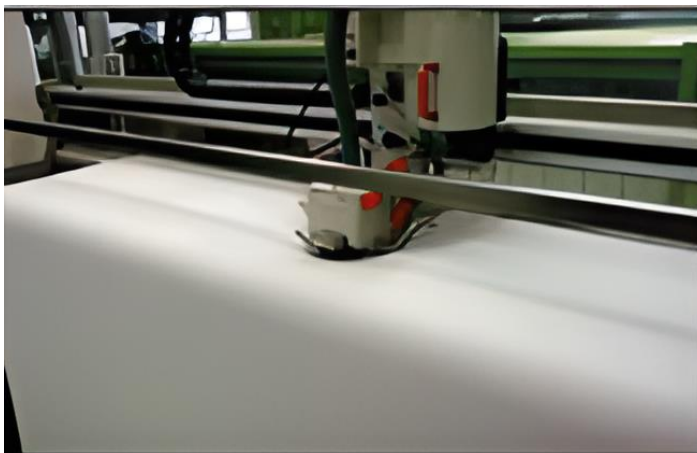

GT

Our Main Suppliers



GT

Contacts

Sales & Spare Parts Department:

Ettore Guarneri (CEO):

e.guarneri@guarneri-technology.it

Andrea Guarneri:

andrea.guarneri@guarneri-technology.it

Spare Parts Team:

aftersales@guarneri-technology.it

Purchase Department:

Stefano Guarneri (Purchase Director):

s.guarneri@guarneri-technology.it

Technical Department:

Alberto Guarneri (Project Leader):

a.guarneri@guarneri-technology.it

Lorenzo Lotrecchiano (Project Assistant):

tecnico@guarneri-technology.it

Financial Department

Enrica Gioppi:

administration@guarneri-technology.it

Cristina Lorenzani:

contabilita@guarneri-technology.it