

OVERVIEW



Textile Engineering

**GALILEO - C701**  
**CARDING SECTION**



**Marzoli**

Complete spinning line,  
components and digitalized  
solutions for the best performance  
of the spinning process





# THE ONE SOURCE FOR A FULLY-AUTOMATED AND DIGITALIZED SPINNING MILL

Marzoli, one of the major brands of the textile sector worldwide, is a unique European manufacturer of the complete line of machines for the opening, preparation and spinning of short-staple fiber. From the bale opener to the ring spinning frame, Marzoli offers the most advanced technology for a completely-automated spinning mill. Through its global sales and service network, its expertise on each type of fiber and application and the competence on the entire process, Marzoli represents a competent and reliable partner. And through its experience, know-how and commitment, it provides its customers with:

- Advanced spinning solutions through a careful activity of textile engineering. Marzoli assists its customers from the study of the spinning plan, throughout sourcing, erection and commissioning, up to maintenance of the resulting turnkey spinning plant, which can comprise Marzoli but also third-party machinery. The customer can rely on the competence and capability of a unique partner, responsible for the quality and productivity of the entire spinning mill.
- The advantages of smart spinning. No matter what the brand(s) of the machinery is, Marzoli can install its software platforms, YarNet and MRM, its hardware applications for gathering data on waste percentages and its composition, quality values, productivity indexes and other kpi data to let the customer build on the potential of Industry 4.0, optimize the entire spinning process through well-informed decisions and reach the highest performance in production operations.

OVER  
**160** YEARS  
OF SUCCESSES

OVER  
**70** COUNTRIES  
WITH ACTIVE CLIENTS



## OPENING SECTION

- Openers & Cleaners
- Mixers & Blenders
- Card

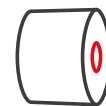

## COMBING SECTION

- Draw Frames
- Lap Winder
- Comber
- Lap Transport



## SPINNING SECTION

- Roving Frame
- Ring Spinning Frame
- Bobbin Transport System

# GALILEO CARD C701

Innovative. Advanced. Modern.

## KEY POINTS

- TOP QUALITY & EXCELLENT CARDING
- HIGH PRODUCTIVITY
- HIGH EFFICIENCY IN ALL DOWNSTREAM PROCESSES
- TECHNICAL & TECHNOLOGICAL EXCELLENCE
- COUNTLESS INNOVATIONS



Carding has always been and will continue to be one of the most important phases of the spinning process. Only with an effective carding of the fiber the spinner can produce a homogeneous, regular, resistant and clean yarn and therefore ensure efficiency and quality in all downstream operations.

The raw material available on the market today, with continuously increasing prices and always less selected quality, is forcing spinning companies to ask for help from textile machinery manufacturers in order to maintain high quality standards in their end product. The card, in particular, becomes a fundamental machine to get the best quality out of any fiber.

From the processing of cotton to artificial and synthetic fibers and also to the new and always more complex technical fibers, the Marzoli C701 Card, with its countless innovative solutions, has been designed to fully satisfy the increasingly demanding requirements of the market on greater production and quality.

The Marzoli C701 Card stands for technical and technological excellence and confirms the great effort of Marzoli in research and development.



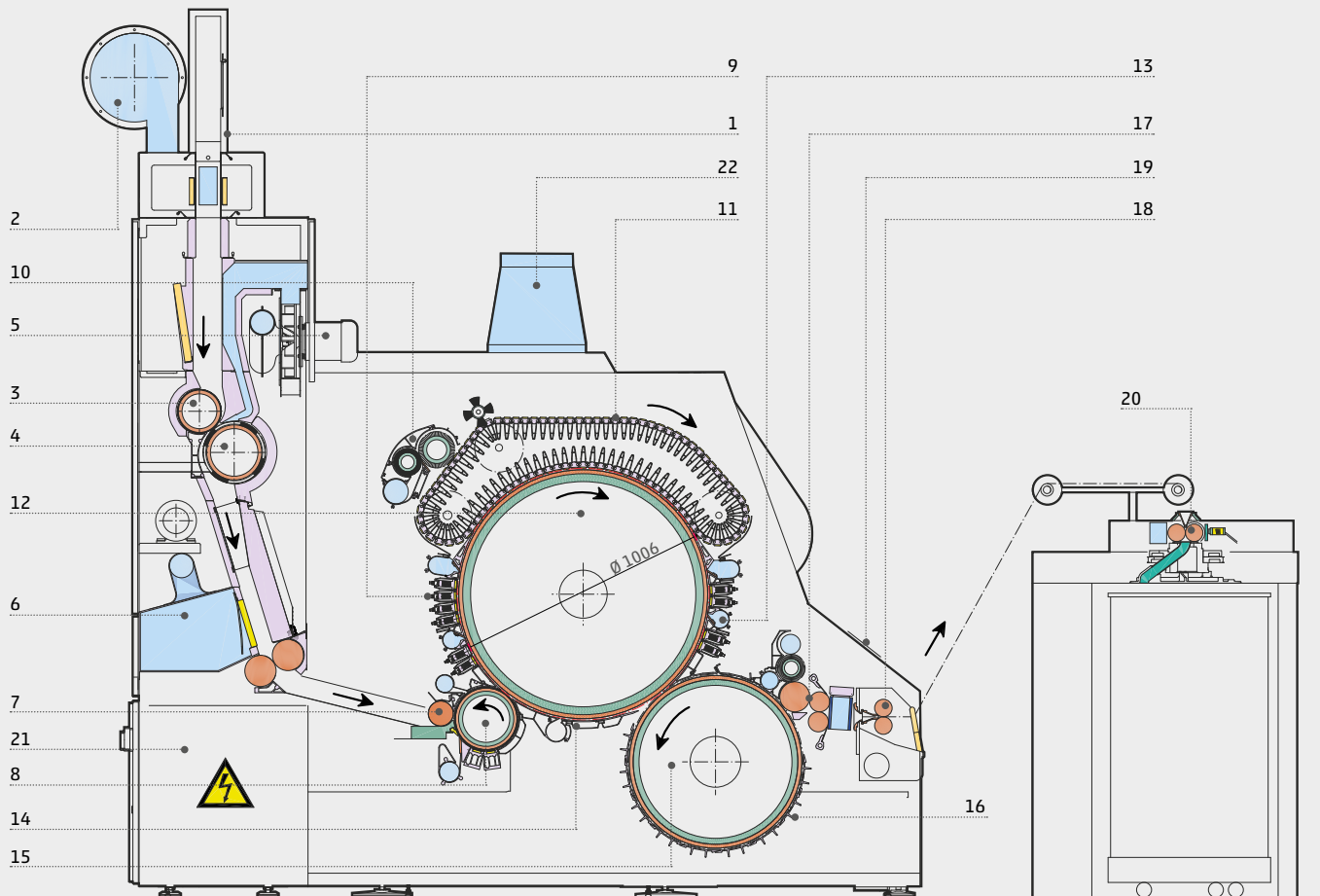

### MACHINE DESCRIPTION - LEGEND

- |                              |                               |
|------------------------------|-------------------------------|
| 1 Control feed inlet         | 12 Main cylinder              |
| 2 Dust extraction outlet     | 13 Postcarding area           |
| 3 Silo feed roller           | 14 Under main cylinder covers |
| 4 Opening roller             | 15 Doffer                     |
| 5 Fan                        | 16 Under doffer covers        |
| 6 Lower air discharge outlet | 17 Sliver forming system      |
| 7 Card feed roller           | 18 Calender                   |
| 8 Licker-in                  | 19 Control panel              |
| 9 Precarding area            | 20 Coiler                     |
| 10 Flats cleaning device     | 21 Electric box               |
| 11 Revolving flats           | 22 Suction system             |



# PATENTED GEOMETRY: OUTSTANDING PRODUCTIVITY & QUALITY

The dimensions of the main cylinder - width and diameter - have important consequences on the machine efficiency, productivity and on its output quality.

Small dimensions reduce the weight of the cylinder, which grants lower friction and minor mechanical stress. Moreover, small diameters, in combination with higher cylinder speed, grant higher centrifugal force, which improves the extraction of impurities. On the other hand, bigger cylinders entail a greater carding surface of the machine. This has three major consequences:

- It improves productivity, because the card can process bigger amounts of raw material.
- It enhances quality and carding effectiveness because the same amount of raw material is distributed on a bigger carding area.
- It reduces maintenance costs because the flats are less subject to wear, as the same amount of fibers is distributed on a greater carding surface.

## KEY POINTS

- LOW FRICTION AND LOW MECHANICAL STRESS
- HIGH ENERGY SAVINGS
- EFFECTIVE EXTRACTION OF IMPURITIES
- HIGH PRODUCTION
- TOP CARDING EFFECTIVENESS

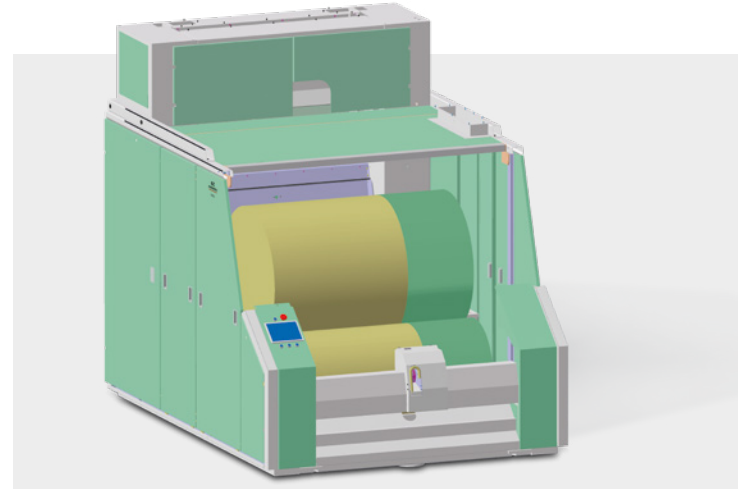

Accurate studies and several tests carried out in the R&D department have led Marzoli to identify the cylinder dimensions that perfectly balance all the above-listed advantages. This technology has been incorporated in Marzoli C701, which currently operates in several spinning plants around the globe.

## MAIN CYLINDER CENTRIFUGAL FORCE

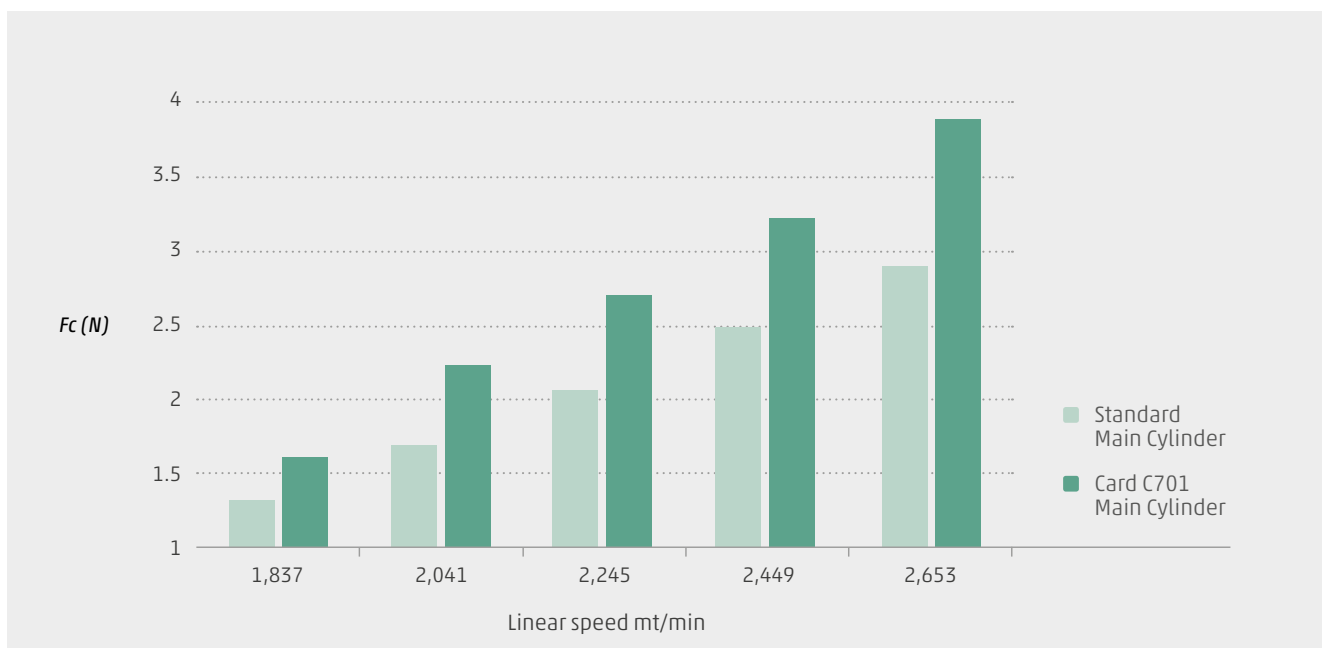



## Big Carding Angle & Carding Surface

In the architecture of the Card C701, the main cylinder has been raised and the licker-in and the doffer have been located underneath the main cylinder in order to reach a 284° carding angle (angle between the center of the licker-in and the center of the doffer). Thanks to this configuration, the working width 1,500 mm and the diameter of the main cylinder of 1,006 mm, Marzoli C701 Card has a carding surface of 3.74 sqm, the greatest carding surface on the world market today.

The carding surface is subdivided as follows: pre-carding area 1.08 sqm, moving flats area 1.57 sqm and the post carding area 1.09 sqm.

C701			
PRE CARDING AREA sqm	CARDING AREA sqm	POST CARDING AREA sqm	TOTAL AREA sqm
1.08	1.57	1.09	3.74

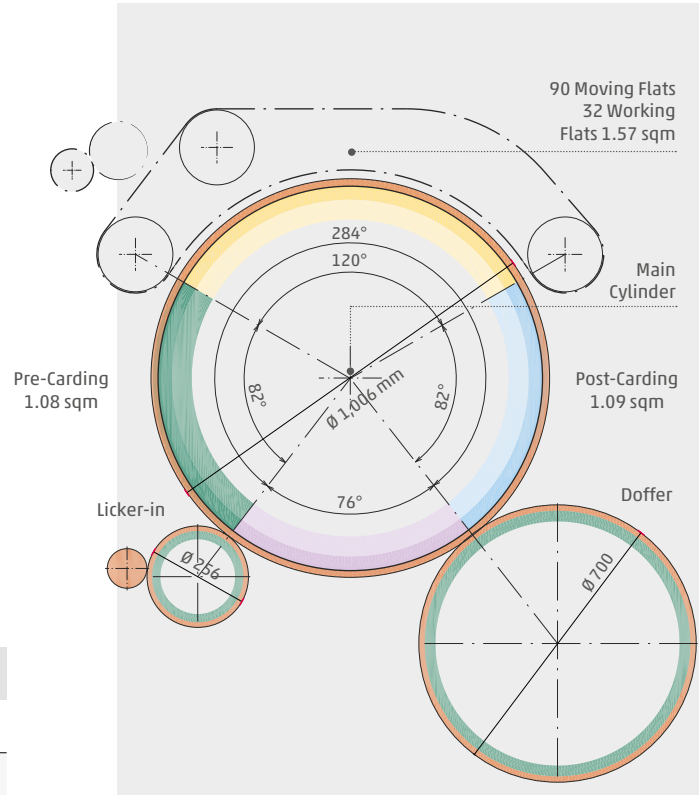

## Carding densities with different main cylinder geometries

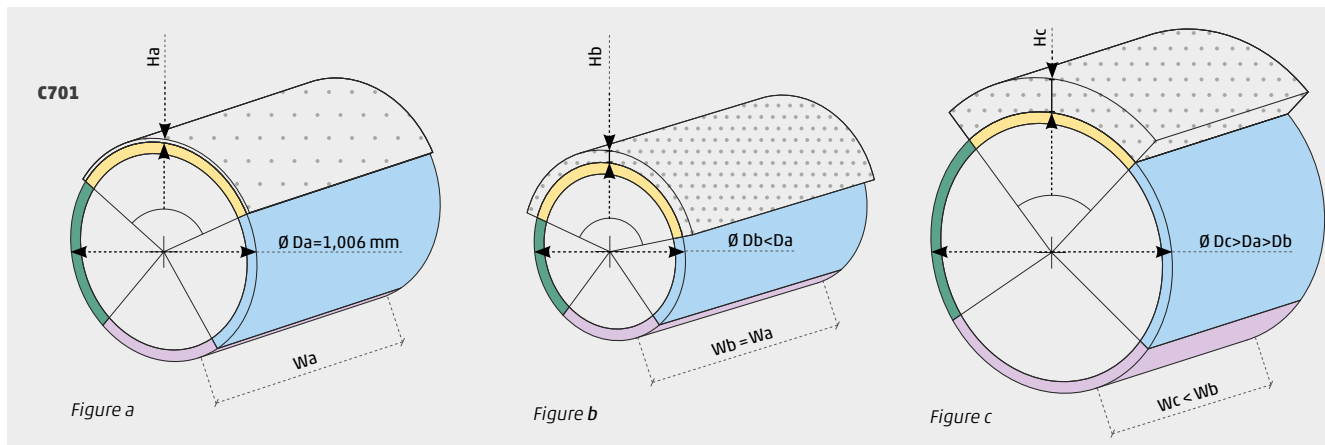

Under the same production levels, the geometry of Marzoli C701 Card allows to reduce the density of the processed material in the carding area with mobile flats (See *Figure a*). This entails a thinner layer ( $H_a$ ) of the carded material with two positive effects:

1. Superior carding performance;
2. Lower mechanical stress on the cloths and the flats.

In fact, with other geometries with smaller diameter and lower working width of the main cylinder (see

*Figure b and c*), in order to keep the same fibers carding density and achieve the same carding quality of Marzoli C701 Card, it is necessary to increase the rotating speed of the main cylinder.

This entails damaging of the fibers, wear of the mobile flats and the carding cloths and high energy consumption.

### TECHNICAL DESCRIPTION - LEGEND

- H Web height
- W Working width
- D Main cylinder diameter

# CHUTE FEED & LICKER-IN

It is well known that the effectiveness of the feed system of a textile machine has remarkable effects on its performances. Therefore, when talking of a card, the main player for silver quality, correct feeding is vital.

The fully integrated chute feed of Marzoli C701 Card is conceived to:

- improve the formation and the evenness of the feeding batt;
- guarantee batt homogeneity;
- increase dust removal efficiency;
- improve cotton opening;
- eliminate fiber curling.

The most innovative features of the integrated chute feed are the following:

- all the convoy parts in contact with the fiber are in stainless steel in order to guarantee maximum fluency with all types of fiber. This solution is available only with Marzoli chute feed;
- the feed table has a special design that allows to feed the batt with smaller and more open tufts;
- the patented system to introduce the air directly in the batt formation chamber in order to transport the fibers without turbulences and without curling;
- in the batt formation chamber, thanks to an innovative solution, the air leaks without collecting any workable fiber;
- all the pre-chute feed elements, the batt formation area and the cylinders are easily accessible from the back side of the card for cleaning and maintenance.

These features, along with the autoleveler on the feed roller, improve carding and the regularity of the silver, achieving very low Uster values for cotton carded sliver.

## KEY POINTS

- IMPROVEMENT OF BATT EVENNESS
- ELIMINATION OF FIBER CURLING
- LOW USTER VALUES FOR COTTON CARDED SLIVER
- SIMPLE MAINTENANCE

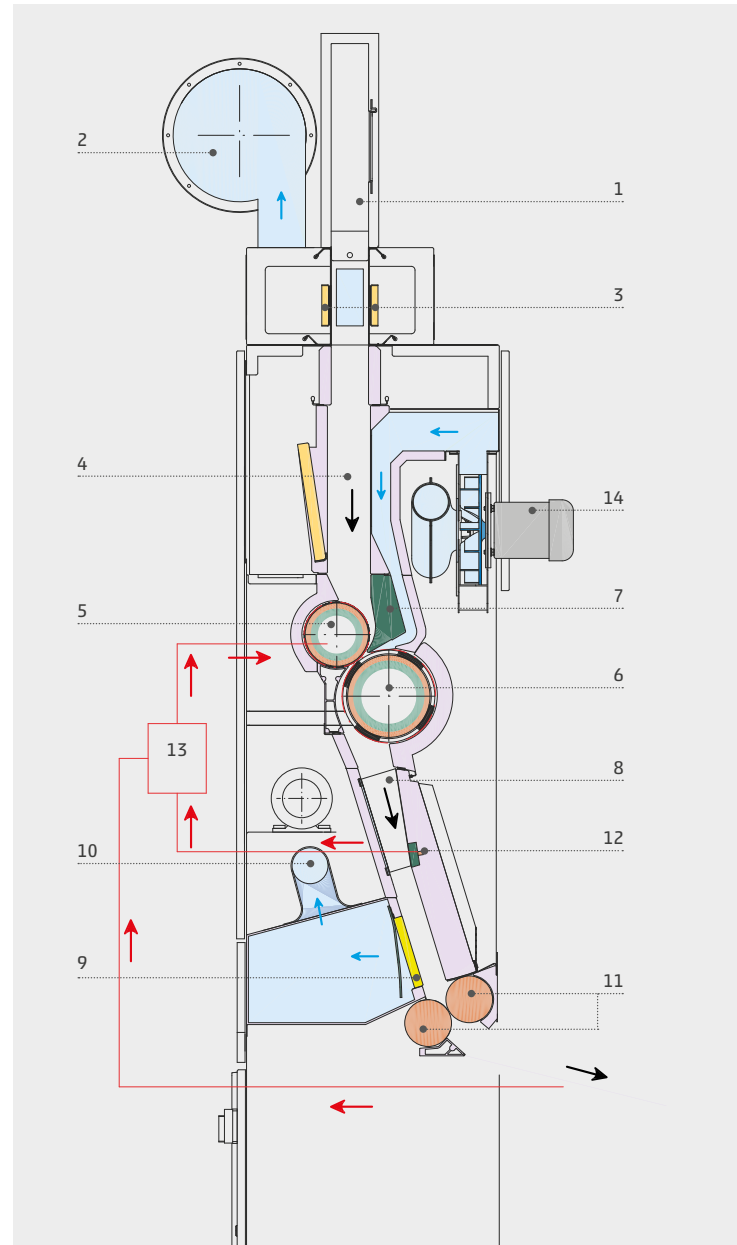

## MACHINE DESCRIPTION - LEGEND

1	Control feed inlet	8	Batt formation chamber
2	Dust extraction outlet	9	Perforated steel sheet
3	Pre-chute feed air discharge outlet	10	Lower air discharge outlet
4	Pre-chute feed chamber	11	Feed rollers
5	Feed roller	12	Pressure detection point
6	Opening roller	13	Control unit (pressure switch)
7	Feed table	14	Fan



## LICKER-IN

### Easy elimination of dust & trash

One of the main objectives of a card is to reduce impurities in the sliver. A very important feature of the C701 is the small dimension of the licker-in that must consequently work at high speed.

The result is a greater centrifugal force that, in combination with the knife and the carding segments positioned underneath the licker-in, contributes to an easy elimination of dust and trash.

The waste percentage adjustment is easily modifiable with the flap positioned in the waste chamber.

### Perfect opening & separation of fibers

In order to allow an effective carding of the fiber it is necessary to open the batt and separate the fibers.

These activities are carried out through a drafting effect, occurring between the feed roller and the main cylinder, that is not affected by the number and the dimension of the licker-in. In fact, in all spinning machines the draft is always and only the ratio between the delivery speed and the input speed: the intermediate rollers do not affect the draft value.

The draft between the feed roller and the main cylinder of Marzoli C701 Card is very high (800) ensuring the perfect opening of the fiber. This adds onto the high cleaning performance stemming from the licker-in dimension, which does not alter the drafting effect in any way.

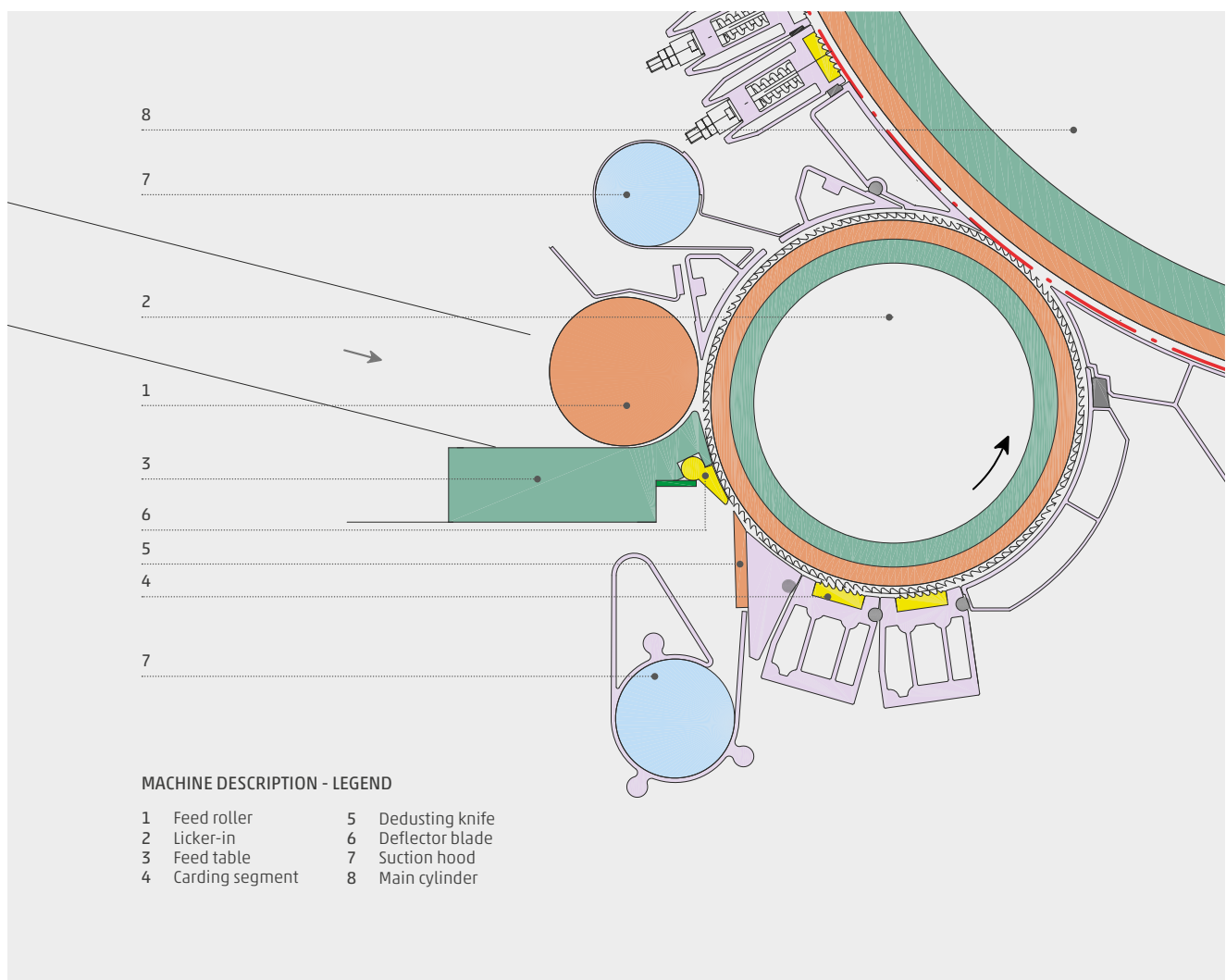

# PRE-CARDING, CARDING & POST-CARDING

## PRE-CARDING

The Card C701 has a pre-carding area of 1.08 sqm, that allows the installation of 6 carding units and 2 fiber control units with relative knives that have the task of removing impurities, dust and short fibers.

The pre-carding zone can be flexibly equipped by choosing the number of carding units and knives on the basis of the processed raw material: up to 8 carding units can be applied with one fiber control element and with relative knife. As shown in the image, the pre-carding area comprises an active and a passive zone. In fact the fiber must be effectively carded, but at the same time must be able to stretch and recover from the carding stress, in order for the impurities to be captured by the knives and by the discharge mobile flats and evacuated through the air suction ducts.

## CARDING

At the heart of every card there is the mobile flats area, the carding zone dedicated to the removal of neps, pepper trash and short fibers. It is in this zone where there can be substantial declines in carding quality and a rapid wear of the card cloths if production is increased because the card must process more fibers in the time unit. This boosts the stress on the fibers and causes a rapid wear of the card cloths: first the cloths of the mobile flats and then the cloth of the main cylinder.

Thanks to Marzoli C701 greater carding area it is now possible to increase production by 50% while maintaining the same carding density.

## KEY POINTS

- TOP CARDING EFFECTIVENESS
- PERFECT EXTRACTION OF IMPURITIES
- CONSTANT OUTSTANDING QUALITY LEVELS
- HIGH FLEXIBILITY FOR ALL TYPES OF FIBER
- SPECIAL DESIGN FOR HIGH PRODUCTION & LOWER MAINTENANCE
- HIGHER PRESERVATION OF THE CARD COMPONENTS

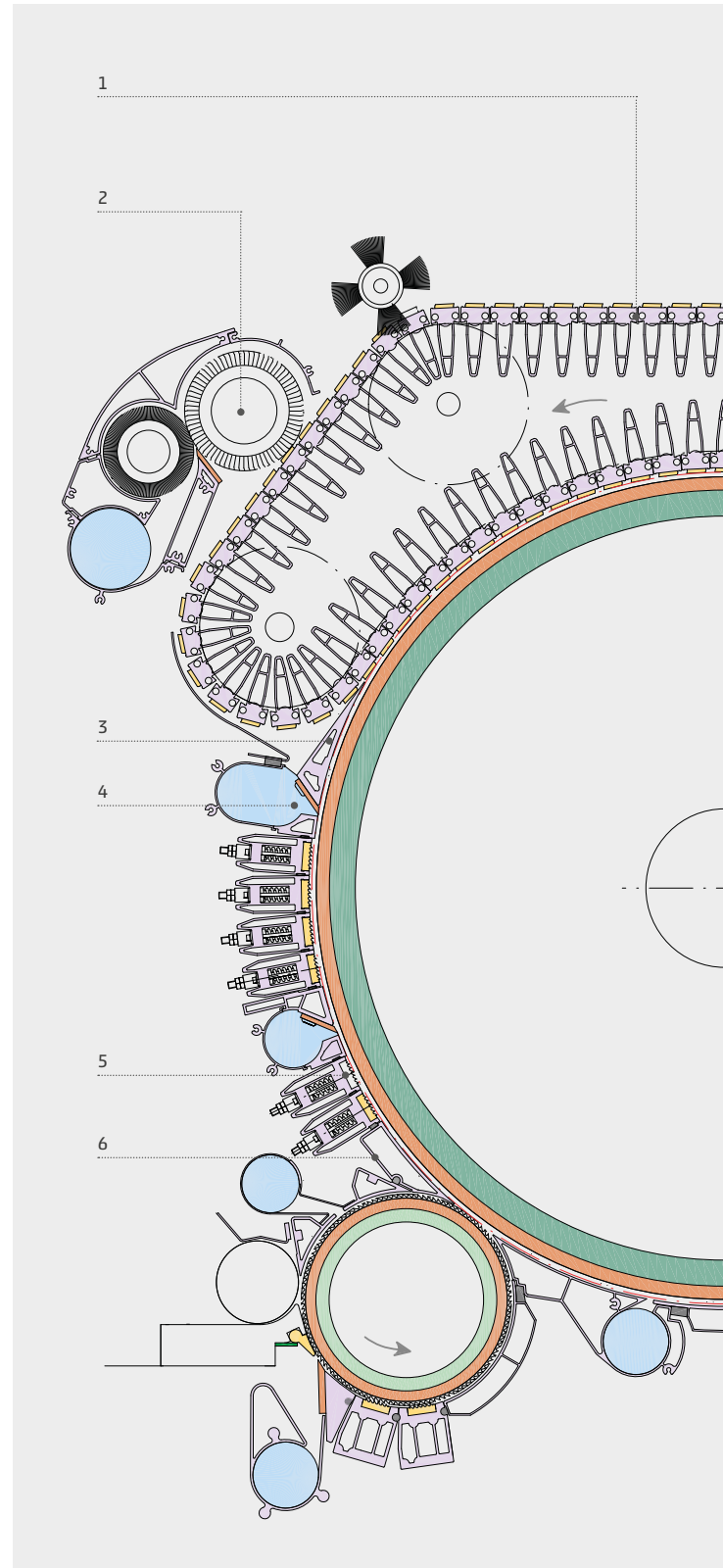



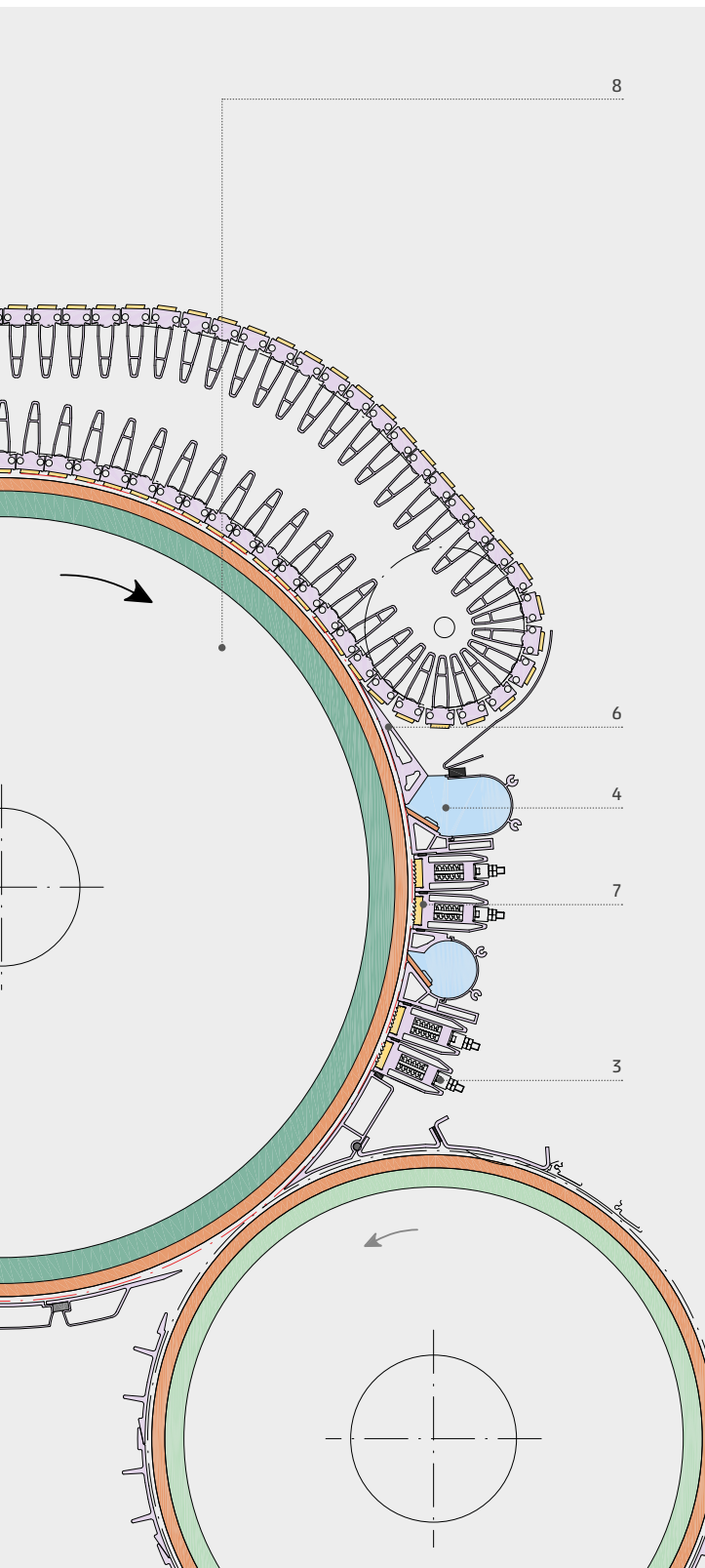

Marzoli Card C701 has a carding zone that has been designed in order to achieve the highest performances in the extraction of impurities, short fibers and trash fragments even when working at superior production levels: the greater mobile flats area (1.57 m<sup>2</sup>) and the 90 mobile flats, of which 32 always working, permit a 50% increase in production with the same ratio between the number of fibers and the number of points, and with the same setting of conventional machines. This guarantees the quality of the sliver and durability of the card clothing.

## POST-CARDING

In the post-carding area, the 1.09 sqm surface has permitted the installation of 4 carding units and 2 fiber control elements with relative knives (in the standard configuration) whose task is to extract the residual impurities (pepper trash) and particles of dust.

The parallelized and cleaned fibers are delivered to the cloth of the doffer.

Also the post-carding zone can be flexibly equipped with different combinations of carding segments.

### MACHINE DESCRIPTION - LEGEND

- 1 Revolving flats
- 2 Flats cleaning device
- 3 Outlet cover
- 4 Dedusting knife with suction hoods
- 5 Pre-carding segment
- 6 Inlet cover
- 7 Post-carding segment
- 8 Main cylinder

# DOFFER & WEB DETACHING DEVICE

## DOFFER

The transfer of fibers from the main cylinder to the doffer is important, because it directly affects sliver cleanliness and uniformity. When the two metallic wires are closest to each other, the different speed of the two cylinders creates a carding action and causes the transfer of fibers from the main cylinder to the doffer. However, the doffer only collects the fibers that enter in contact with its metallic wire: if the distance between the main cylinder and the doffer is too large or if the doffer is overloaded with fiber, the transfer and the carding action between the main cylinder and the doffer are inhibited. Marzoli C701 Card has a design that specifically addresses these problems.

In particular the C701 design has achieved:

- minimum mechanical distance between the main cylinder and doffer for an optimum transfer of fibers;
- large working surface between main cylinder and doffer (contact zone) thanks to the employment of a 700mm diameter doffer, which has always been used on Marzoli cards.

In conclusion, the design and the highly precise construction of the main cylinder and doffer supporting structure are the premises for a stable and reliable production of high quality sliver.

## KEY POINTS

- PERFECT SLIVER CLEANLINESS & UNIFORMITY
- RELIABLE PRODUCTION OF HIGH QUALITY SLIVER
- MINIMUM MECHANICAL DISTANCE BETWEEN MAIN CYLINDER & DOFFER
- LARGE CONTACT ZONE BETWEEN MAIN CYLINDER & DOFFER

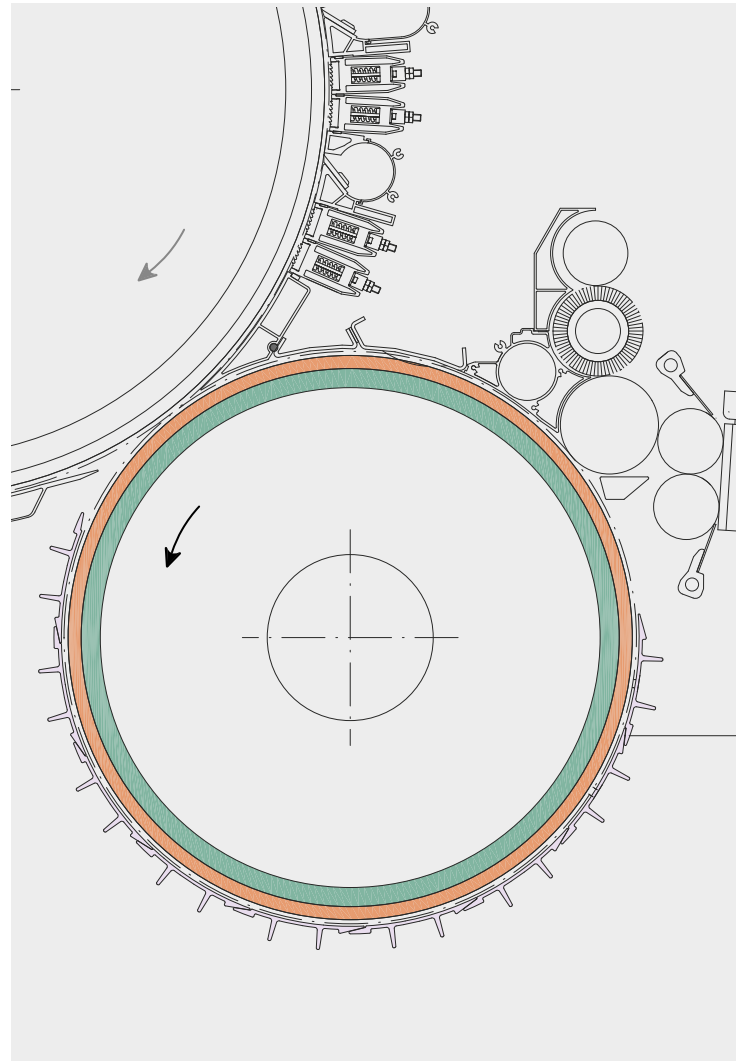

## WEB DETACHING DEVICE

A key success factor for spinners is to boost productivity without compromising on quality. On one hand, productivity allows to reduce the investment cost; on the other hand, higher production levels require higher working speed which can damage sliver quality and uniformity, cause breakages of the sliver and, hence, affect the efficiency and productivity of downstream operations.

The productivity-quality trade off can be substantially improved in some key areas. One of these areas is where the web detaches from the doffer. Thanks to Marzoli technology, the web detaching device of C701 can work at high production volumes without compromising on quality.

The web delivery area between the doffer and the web detaching device allows for an ideal transfer of fibers. The subsequent sliver formation with transverse movement makes it possible to process all known fibers at elevated delivery speeds, which is equivalent to high productivity, without compromising web quality.

### Web extraction calender

The sliver insertion device with extraction calender, with its automatic rollover allows a quick and easy reattachment of the web at minimum running speed and guarantees optimum control at high production speeds.

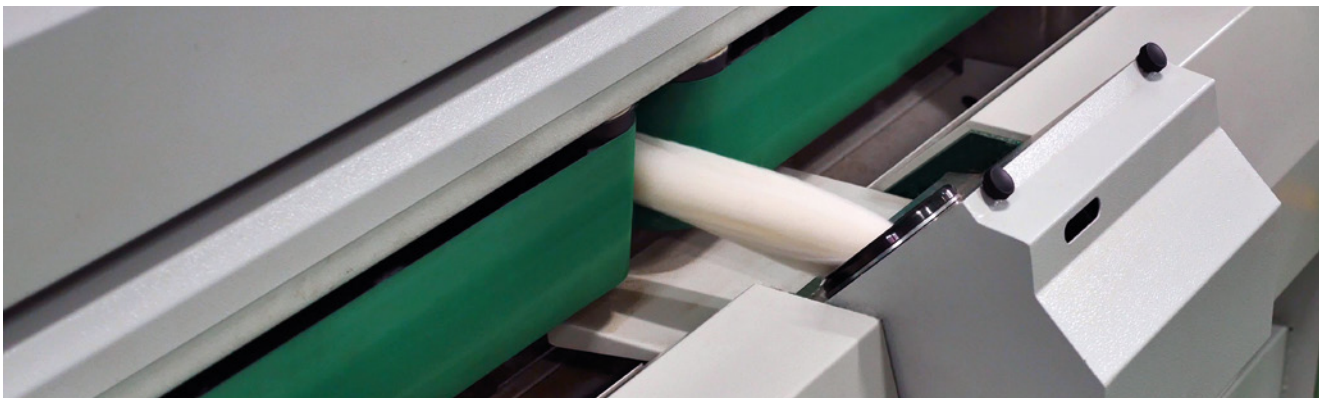
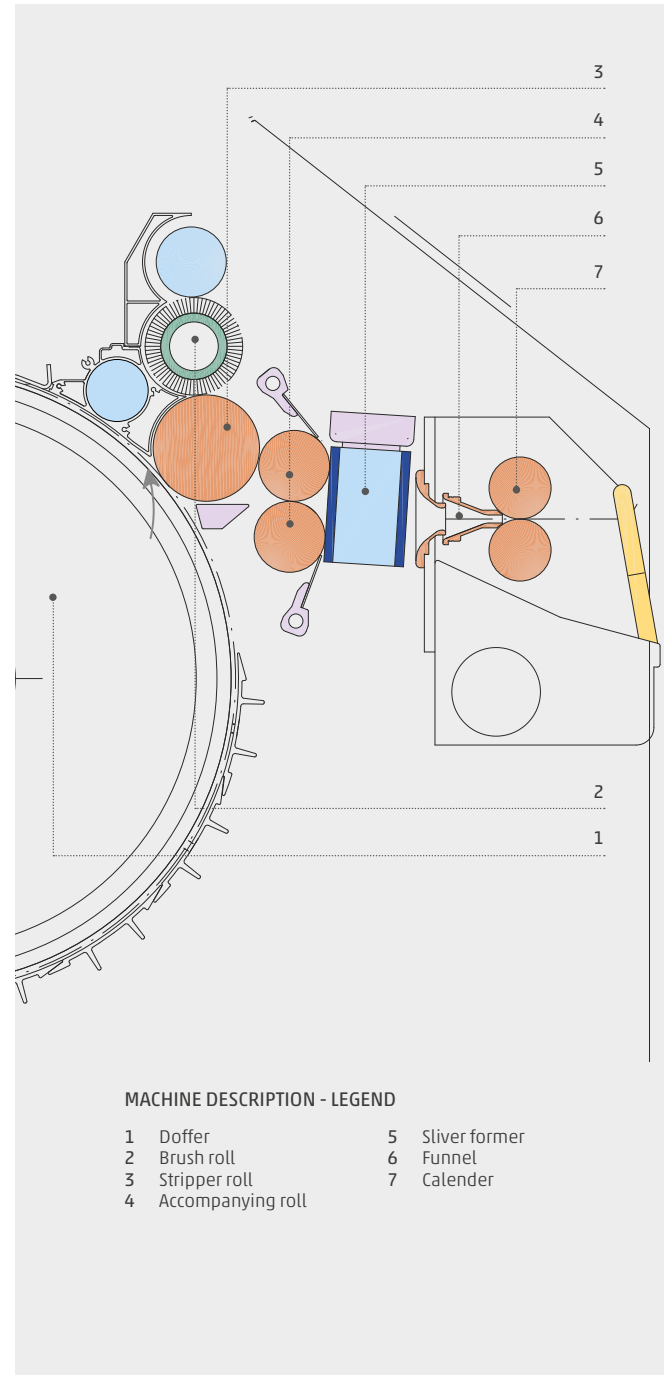



## INTEGRATED DRAFTING SYSTEM (OPTIONAL)

Marzoli Integrated Drafting System is a 3-over-3 drafting unit equipped with auto-leveling technology and represents the ideal option to ensure superior uniformity of the card sliver.

It is perfectly integrated with Marzoli C701, both mechanically and electronically and there is no increase in the required space if compared to a standard C701. Marzoli Integrated Drafting System gives the possibility of skipping processing at the finisher draw frame and feed rotor spinning machines directly (the drafting unit can be combined with a coiler for cans with diameters of 18" or 20").

### KEY POINTS

- SUPERIOR UNIFORMITY OF THE CARD SLIVER
- PERFECT MECHANICAL & ELECTRONIC INTEGRATION
- SHORTENING OF THE ROTOR SPINNING PROCESS

The drafting rollers are driven by independent motors and the drafting parameters are inserted through the control panel of the machine. The pressure on the top rollers is performed pneumatically and for each roller it can be set independently. The overturning of the whole unit grants easy access for piecing.

The design of Marzoli Integrated Drafting System makes it a more economical and easy-to-manage solution than the drafting units installed above the coiler.

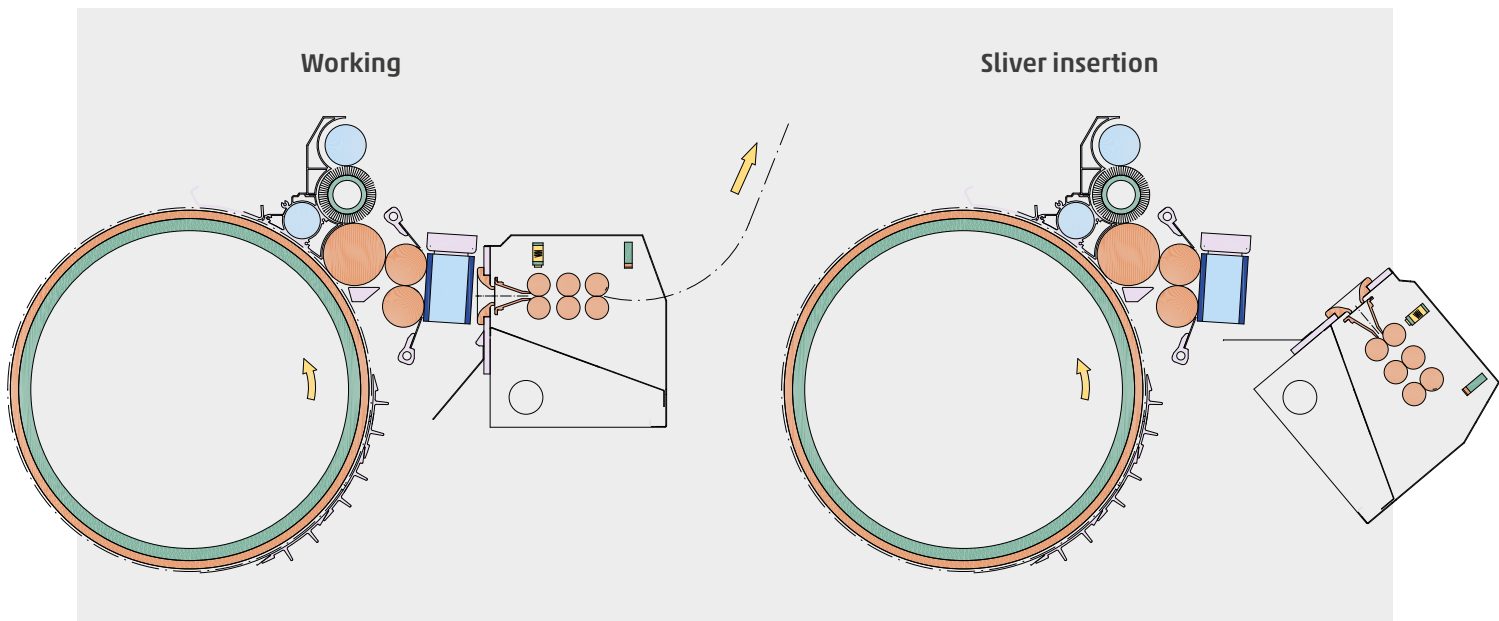

### TECHNICAL DATA

Integrated Drafting System	
Draft range	from 1,1 to 2,1
Installed Power	1,8 kW
Net weight	50 kg
Rollers diameters	44 - 45 - 45 mm

## WEB DELIVERY

### Higher quality web for Nonwoven production

Among the segments comprising the textile industry, few have enjoyed the continuous and rapid growth of nonwovens. Nonwoven production has reached over 2 million tons per year only in Europe and the installed capacity will continue to grow worldwide. A clear trend in the nonwoven sector is the increase of web quality: nonwoven manufacturers are increasingly required to produce webs with homogeneously-distributed fibers. The machine that entails the highest quality results on nonwoven webs remains the card with revolving flats.

Marzoli C701 Card can be equipped with a dedicated web delivery module in order to produce outstanding quality webs, at high production speeds, with low energy consumption. This once again demonstrates the excellent versatility of Marzoli C701 and the great effort that Marzoli dedicates to research and development.

Marzoli C701 Card can be equipped with condensing and randomizing cylinders that allow to reach a web weight of 100 g/m (depending on the type of fiber being processed) and a production level of 270 Kg/h.

By removing the sliver formation unit, it is possible to install the web delivery module also on existing C701 cards.

#### KEY POINTS

- TOP QUALITY WEB
- GREAT EFFICIENCY & LOW ENERGY CONSUMPTION

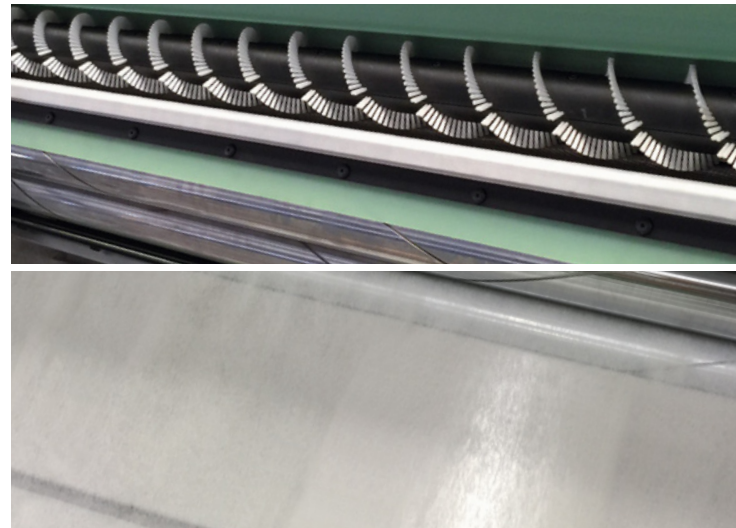

#### TECHNICAL DATA

C701 with web delivery	
Material	Cotton, synthetic fibers
Production	Up to 220 kg/h (up to 180kg/h for bleached cotton)   Up to 270 Kg/h (with condensing and randomizing cylinders)
Web Weight	Up to 40 g/m   Up to 100 g/m (with condensing and randomizing cylinders)

# SUCTION, AUTOLEVELER & USER-FRIENDLY INTERFACE

## KEY POINTS

- SUCTION SYSTEM DESIGNED FOR HIGH PRODUCTION
- PERFECT CLEANING OF THE MACHINE
- EFFICIENT REMOVAL OF ALL IMPURITIES
- MINIMUM RATIO BETWEEN REQUIRED AIR & PRODUCTION
- LOWER ENERGY CONSUMPTION



## SUCTION

One of the key functions of a card is to remove impurities from the raw material and to eliminate them in order to keep all working organs clean and allow them to always work at their best. In modern cards, this activity is carried out by air: card suction systems have a very important role and they must also be efficient because of the high production and moving cost of air. The suction system of Marzoli C701 Card has been designed with consideration of the bigger working width of the machine (+50%), of the increase in production and of the resulting increase in impurities (trash) to be removed. The suction system has been designed and produced using real data collected from various spinning plants, the extensive technological expertise accumulated in Marzoli and the cooperation with partners specialized in software for fluid dynamics applications. The meticulous care given to the design has produced a suction system that guarantees excellent trash removal and machine cleaning, while containing the amount and pressure of the air needed.

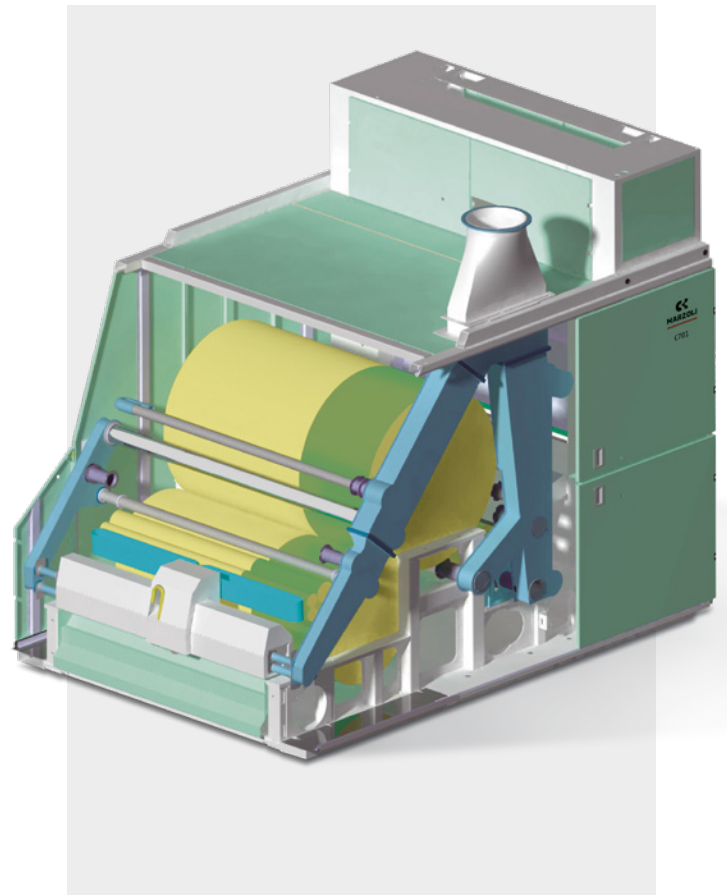

## AUTOLEVELERS

In order to control sliver count variations and to provide a great improvement in the evenness of the card sliver, the Card C701 is equipped, as standard, with the medium-short autoleveler (MTA).

The MTA leveler senses the thickness of the feed material and its variation determines a variation of the speed of the feed roller that allows to maintain the same evenness of the web. This system functions over a medium-short term which guarantees perfect leveling of the web with great benefits for yarn quality.

### MACHINE DESCRIPTION - LEGEND

- 1 Feed roller
- 2 Incoming material
- 3 Feed table
- 4 Lever
- 5 Autoleveler sensor
- 6 Controller
- 7 Feed roller drive (brushless motor)

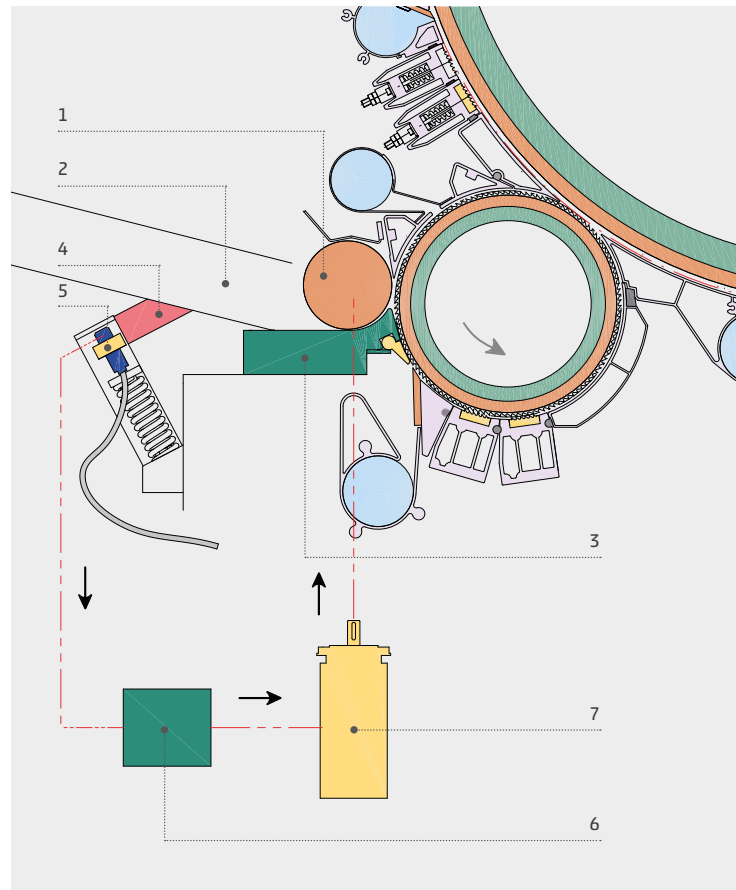

## USER-FRIENDLY INTERFACE

The card C701 is managed by a modern PC microprocessor: all the production data and the working parameters are controlled and saved during the production cycle.

The multi-language touch screen is user friendly and permits a simple use with clear diagrams, detailed monitoring pages and step-by-step trouble shooting procedures.





# COILER/CAN CHANGER, SLIVER MONITORING AREA AND COVERS

## KEY POINTS

- INNOVATIVE DESIGN OF THE COILER
- SIMPLIFIED MECHANICS
- MORE EFFICIENT & PRECISE MOVEMENT OF THE CANS
- CONSTANT CONTROL OF SLIVER EVENNESS
- FULL ACCESSIBILITY OF THE MACHINE
- BETTER & QUICKER MAINTENANCE

## COILER/CAN CHANGER

In order to preserve the maximum width of the Card C701 (structure, body and coiler) similar to the one of the previous model, it was necessary to move the distributor from the side to the front of the machine. This was done to maintain unchanged the number of cards that could be placed side by side given a fixed amount of space available.

The need to redesign the coiler presented the opportunity to introduce concepts such as, for example, the pendulum movement that simplifies the mechanics and makes the movement of cans a lot more efficient. In addition, the centering of the cans has been improved by increasing the can location guides from 2 to 4, guaranteeing more precise and better positioning.

## SLIVER MONITORING AREA

A continuous control and monitoring of the sliver is located on the last area of compaction of the sliver to guarantee constant quality control.

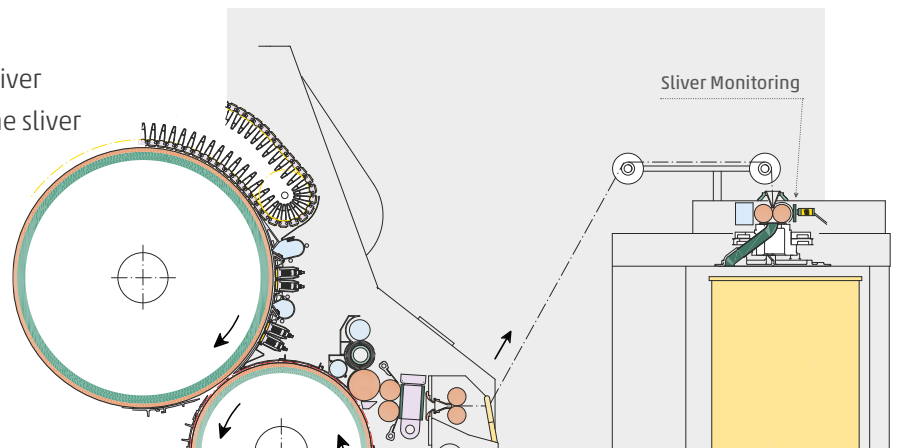

## COVERS

The design of the external covers of Marzoli C701 Card allows to easily access every part of the card for better and quicker maintenance and cleaning of the machine. The sliding doors of the C701 Card can be easily moved to a "parking" position. As clearly shown in the picture, the parking system allows full access to every part of the machine without any restrictions, with great benefits to mobility and visibility for maintenance personnel.

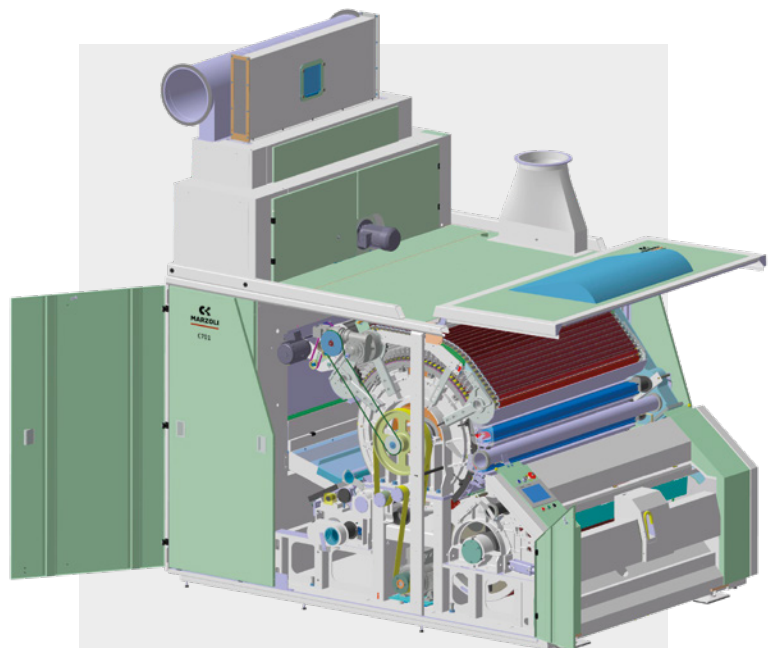

# PRODUCTIONS & BENEFITS

## ACHIEVABLE PRODUCTION

Production up to 270 kg/h.

These productions are achievable thanks to:

- big carding surface (cylinder width, diameter and carding angle);
- working width of 1,500 mm;
- increased centrifugal force on licker-in and main cylinder;
- containment of inertia;
- reduced weight and mechanical stress.
- contained radial expansions in the main working systems;
- reduced distance setting between carding components (the minimum mechanically achievable);
- wide contact zone between main cylinder and doffer, thanks to the 700 mm doffer.

## KEY POINTS

- PRODUCTION UP TO 270 kg/h
- GREAT ENERGY SAVINGS (kW/kg)
- LOWER OPERATING COSTS

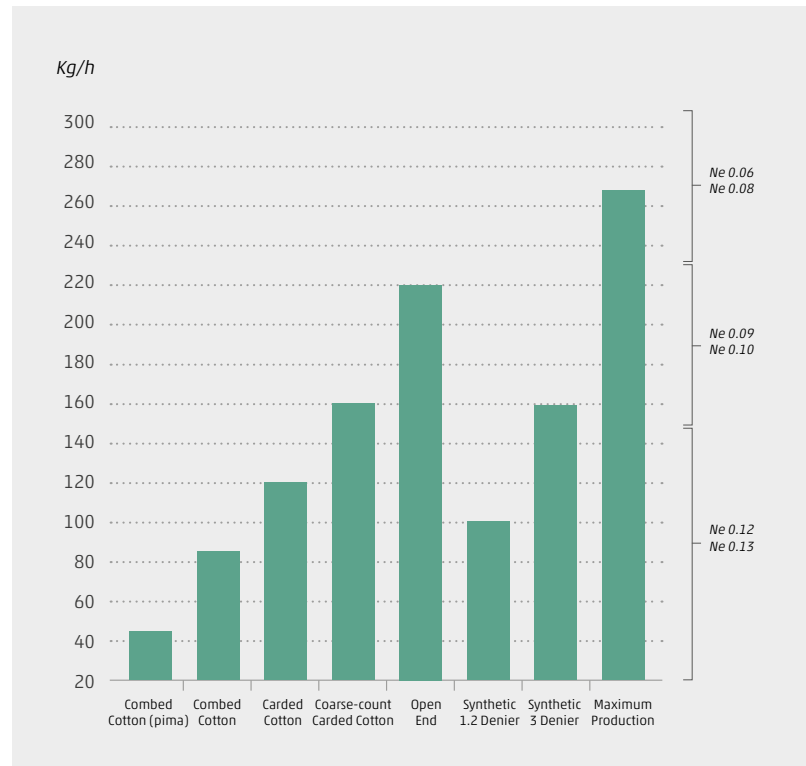

## BENEFITS OF THE C701

Thanks to the higher productivity, Marzoli C701 allows the customer to reach the same production level with a lower number of machines, with obvious and remarkable benefits:

- lower investment costs;
- less space requirements and lower building costs;
- lower costs for suction and related filtration;
- lower maintenance costs thanks to longer metallic wires life;
- greatly reduced energy consumption: reductions of kW/Kg of sliver up to 30%;
- less personnel required thanks to the reduced number of machines and to the improved efficiency.



## TECHNICAL DATA

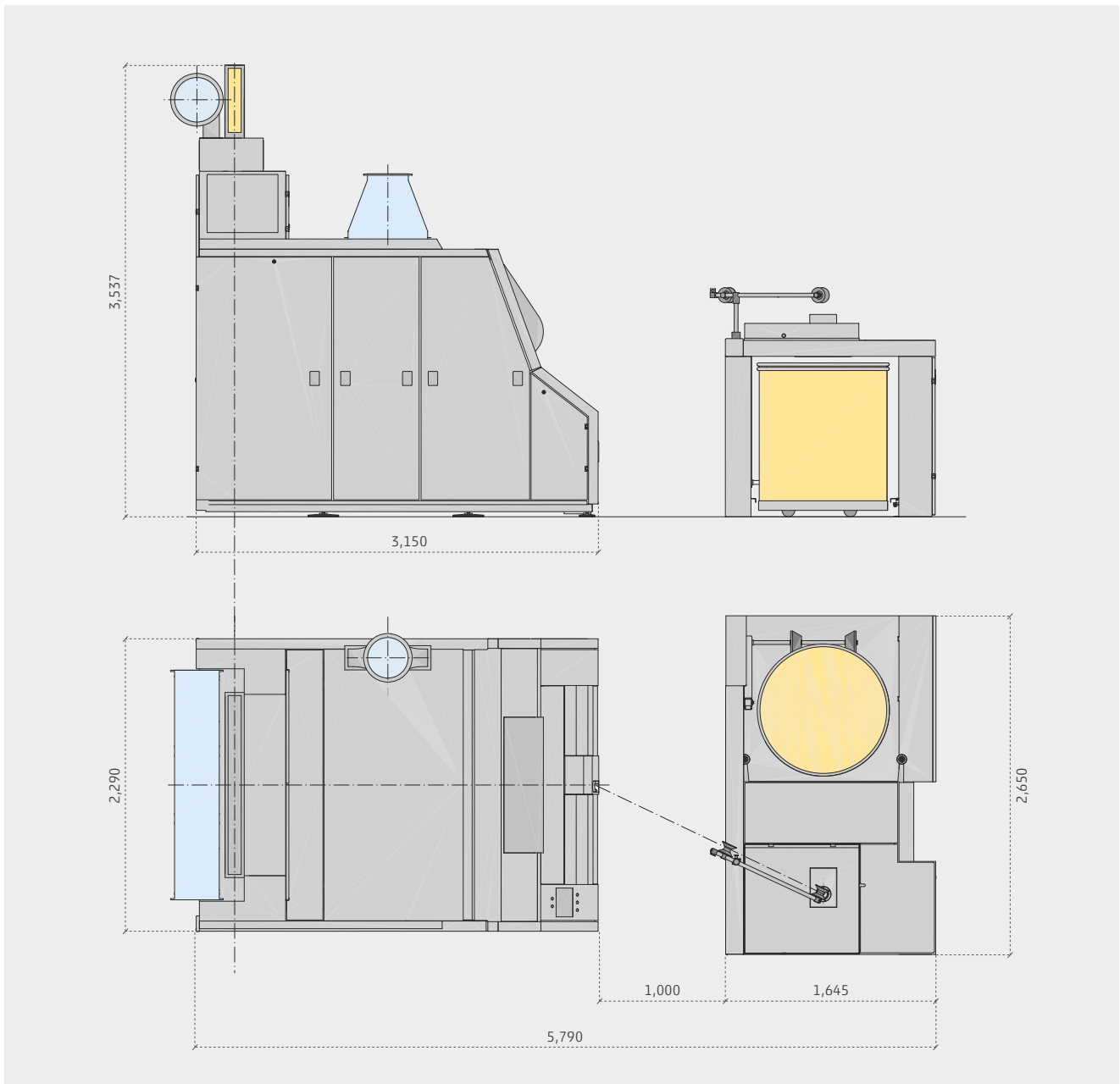

### C701

Processed fibers	Cotton, man-made fibers and wool with staple length up to 65 mm (2" ½)
Production	Up to 270 Kg/h
Installed power	26 kW (with MTA autoleveler)
Delivered sliver count	Ktex 3-40
Suction type	continuos

### Compressed air

Free air consumption	1,000 NI/h
Pressure	8 bar

## POWER CONSUMPTION: MARZOLI C701 CARD

The equipment manufactured by Marzoli is conceived, designed, developed and built with the goal of offering affordable quality and excellent performance within the production process, so that the final product will have a competitive advantage that is created starting

with the earliest stages of production. Marzoli cares about energy consumption saving and its R&D office aims at reducing the environmental impact of its products and lines.

### REDUCTION IN POWER CONSUMPTION LAST 20 YEARS

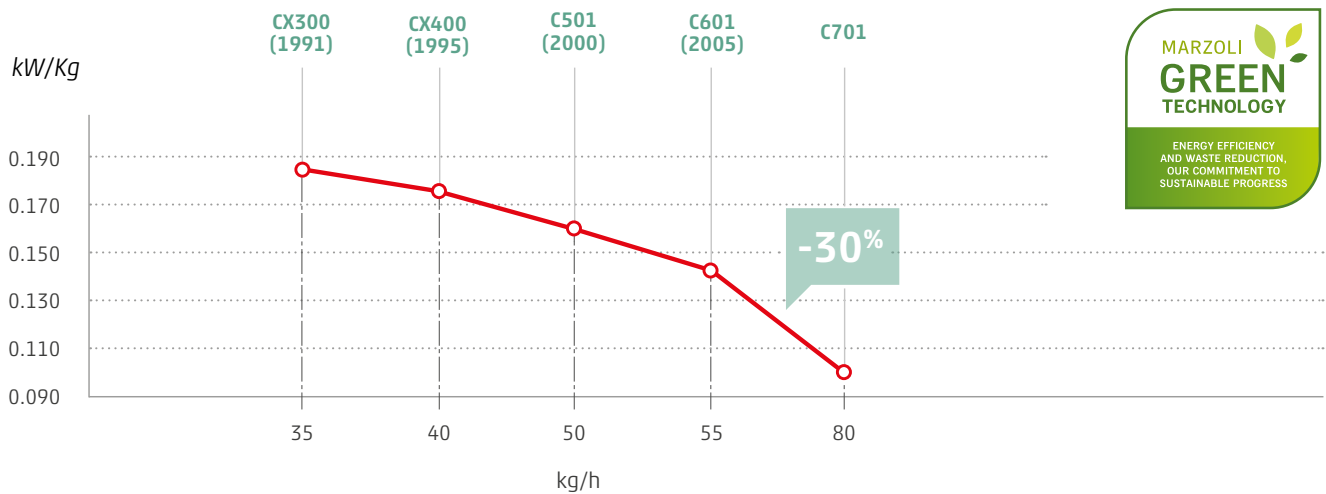

### C701 POWER CONSUMPTION

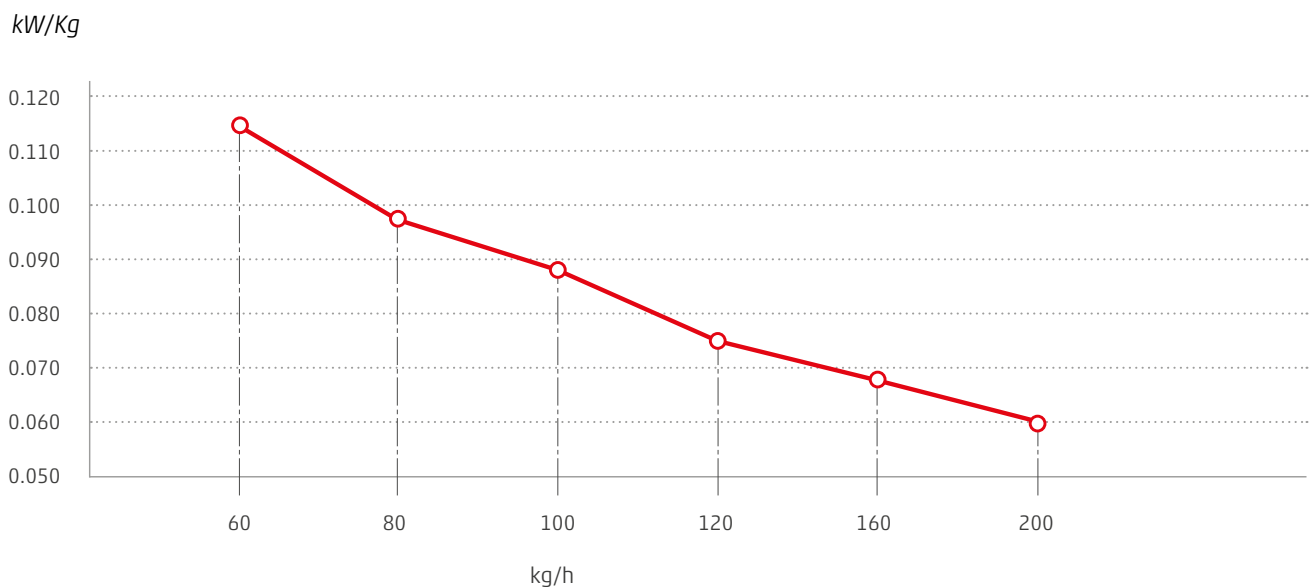



# SOFTWARE PLATFORMS

## END2END PRODUCTION MANAGEMENT PLATFORM: YARNET

YarNet is Marzoli production management software. It enables the monitoring of production levels, efficiency rates and downtime for both individual machines and the entire spinning mill. Comparisons between machines on selected periods of time are made very simple so that improvement opportunities can be easily identified. YarNet enables the operator to edit production recipes, downloading and uploading them between any machine and their computer. He can also export them in Excel format to share with colleagues as necessary. YarNet gathers and analyses data about production and energy consumption, giving a visual representation of the tradeoffs (kW/kg).

## MRM

MRM is Marzoli software to continuously monitor the operating conditions of textile machines. It can identify developing malfunctions before a fault occurs and highlight improvement opportunities on efficiency rates and energy consumption levels. Data about temperature, power consumption, speed and vibration are collected from PLCs (programmable logic controllers) and sensors installed on each machine. The software verifies the monitored parameters are within the nominal operating ranges; it can even adjust for room temperature variations to ensure continuous optimisation. If any parameter is out of tolerance, an automatic email alert is sent to the customer. The customer can also access the dedicated online portal to see information for predictive maintenance and of the overall efficiency of the plant. Through dedicated modules (Optimisation Tools) it is possible to optimise the performance of every machine, in particular on energy consumption and levels of efficiency. If required, Marzoli's customer service team can access the data to diagnose actual and developing problems and recommend appropriate actions.

## KEY POINTS

- EASY & FAST CONTROL OF EVERY STAGE OF THE SPINNING PROCESS
- IMPROVED SPEED OF RESPONSE IN PRODUCTION OPERATIONS
- EASY MANAGEMENT OF PRODUCTION RECIPES
- SUPERIOR, EASIER AND FASTER MAINTENANCE

# YARNET

Marzoli Production Management

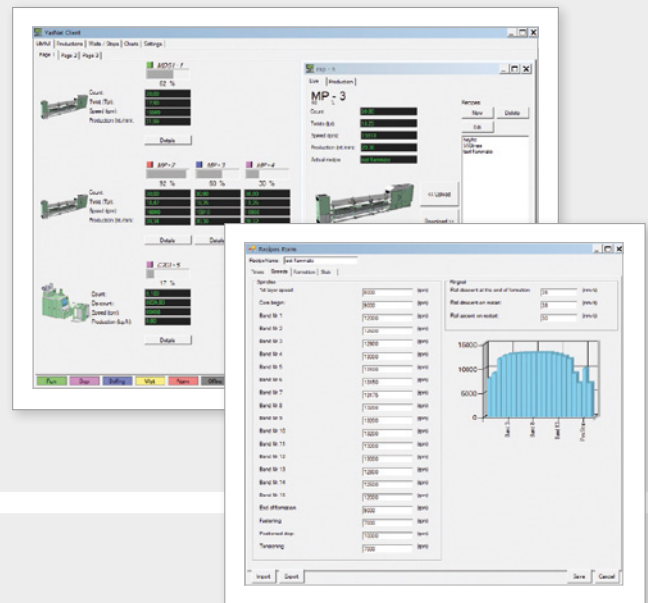

# MRM

Marzoli Remote Maintenance

IoT Platform by Microsoft®

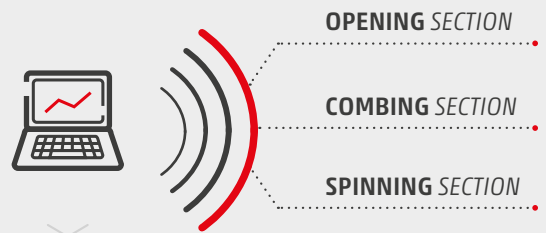

## BENEFITS

- Higher productivity
- No machines unplanned downtimes
- Prevention from major machine failures
- Longer plant lifespan
- Higher efficiency
- Complete reliability
- Trouble free spinning experience
- Better maintenance planning



MARZOLI  
INTERNATIONAL, INC.  
USA

MARZOLI MACHINES  
TEXTILE SRL  
Italy

MARZOLI INDIA  
MTMM PVT. LTD.  
India

- Legend**
- Marzoli premises
  - Sales & service network
  - Sales affiliates

**Marzoli Machines Textile S.r.l.**  
Via Sant'Alberto, 10  
25036 Palazzolo sull'Oglio (BS)  
Italy  
Tel. +39 030 73091  
sales@marzoli.it

**Marzoli International, Inc.**  
100 Corporate Dr., Suite M  
Spartanburg, SC 29303  
U.S.A.  
Tel. +1 864 599 7100  
Fax +1 864 599 7111  
sales@marzoli.com

**Marzoli India  
MTMM Pvt. Ltd.**  
Shed No 6, Bangalore Main Road  
SIDCO Industrial Estate  
Hosur - 635 126  
Krishnagiri District, Tamil Nadu  
India  
Tel +91 4344 400111

  
**MARZOLI**  
Textile Engineering