

**ASSEMBLY WINDER PPW-A.
PRECISION PROPELLER WINDING.**

—
STAPLE FIBRE YARNS.

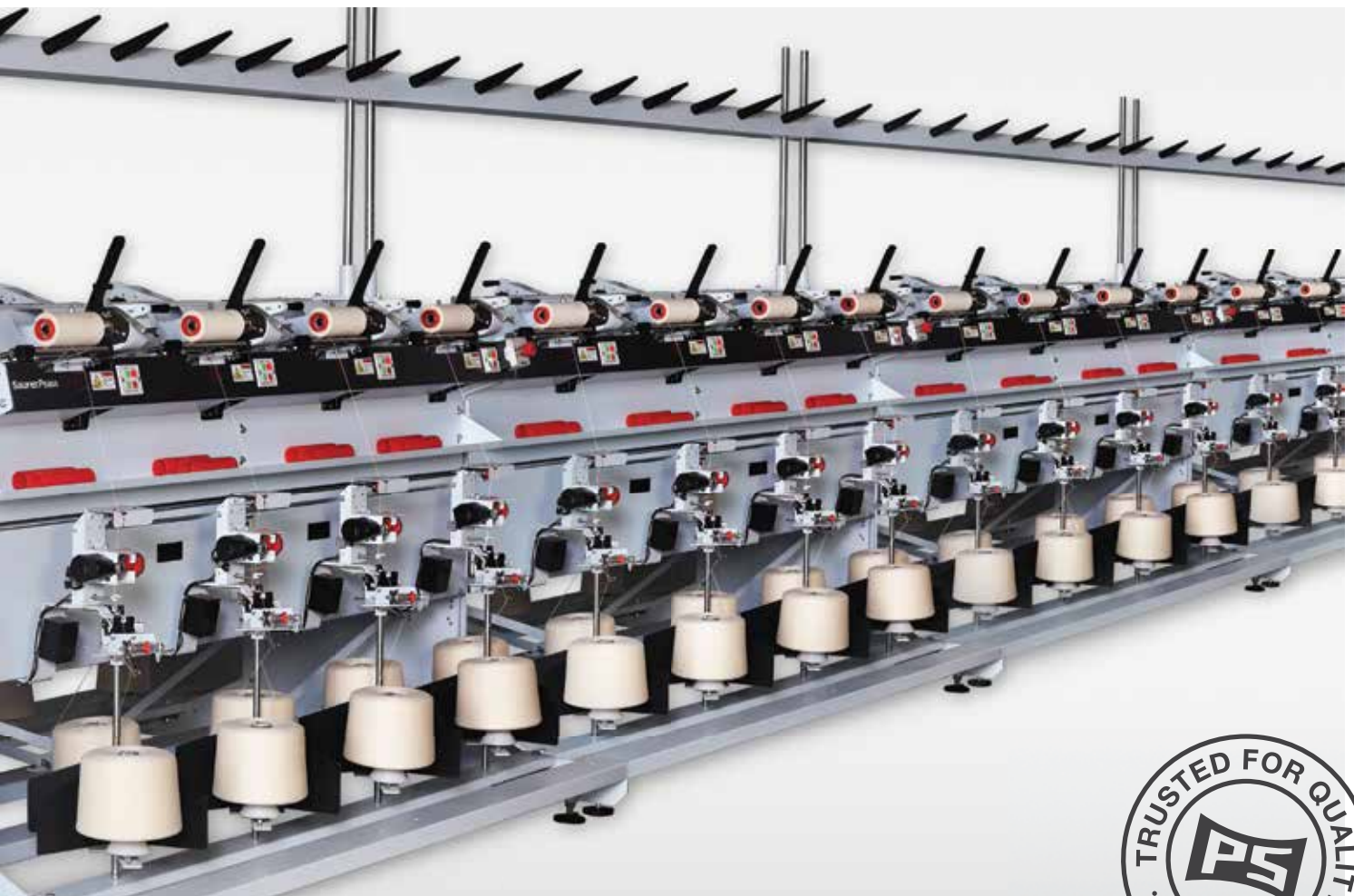

Precision assembly winding means better twisting.

Assembly winding and twisting systems

On precision assembly winding machines, high delivery speeds and due to precision winding high winding densities are reached. These are approx 25% higher compared with random wound packages.

Comparison:

Assembly wound package 6" travers, dia. 135mm cyl., tube dia. 43mm, Nm 40/2 Co

Litre weights – random winding: 900 - 960 g

Litre weights – precision winding: 1120 - 1175 g

Thanks to the high litre weights of precision packages, you can work with optimised feed package weights on twisting machines.

This means high twisting machine efficiency and long knot-free yarn lengths. Twisting of precision wound feed packages is characterised by continuous flyer speeds and, as a result, a stable yarn balloon behaviour.



PPW-A – Precision winder for the following twisting process

Saurer in close corporation with Peass optimized the precision propeller winder for the following two-for-one twisting process of their staple fibre twisting machines.

The Hi-Tech PPW-A provides perfect feed packages to twisting machines ensuring highest productivity and best quality.

Precision winding results in following benefits:

Quality

- ▶ Reduced hairiness increase
- ▶ Zero split ends
- ▶ Zero patterning and ribboning zones
- ▶ More knotless yarn lengths
- ▶ Perfect unwinding properties

Productivity

- ▶ Higher speeds of up to 1200 m/min
- ▶ Reduced yarn breakage rate on TFO
- ▶ Optimized running time of TFO
- ▶ Improved efficiency of TFO

Straight yarn path

- ▶ Gentle handling of yarn
- ▶ Ceramic guiding elements
- ▶ Self threading

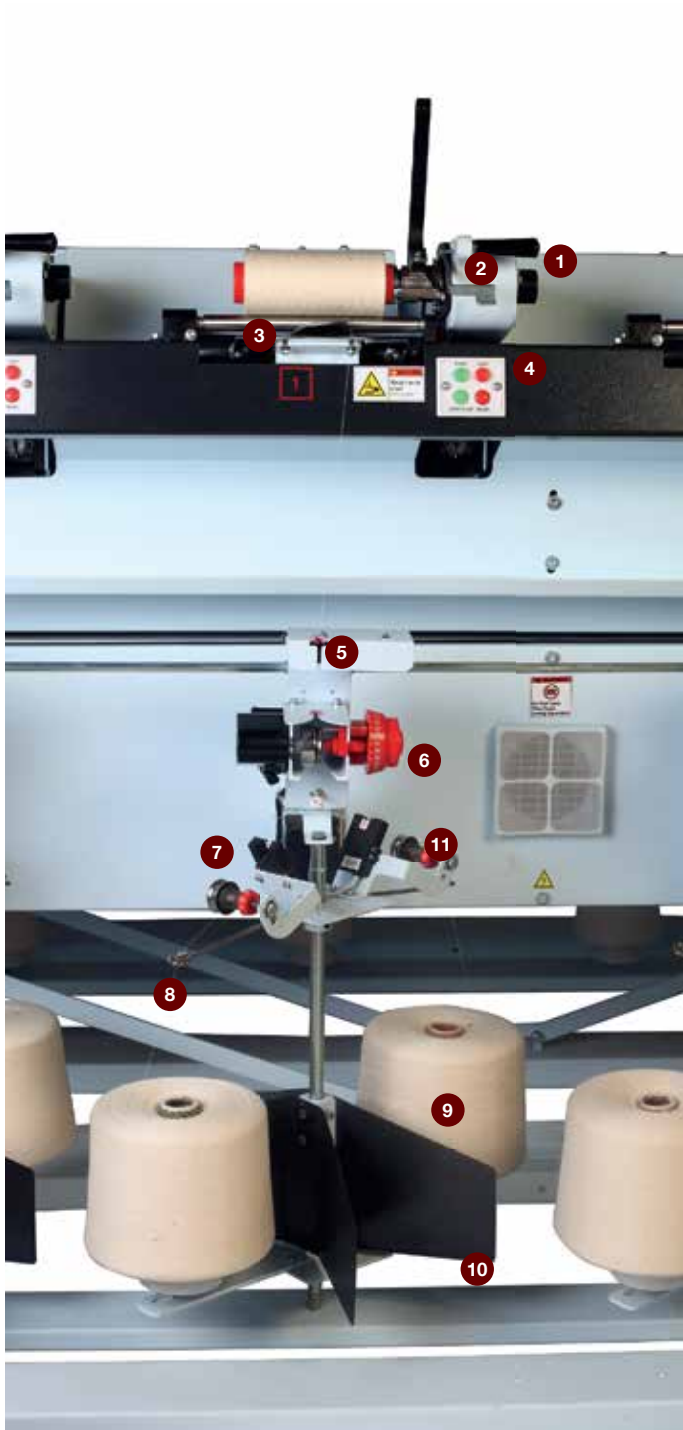

Outstanding features

- 1 Diameter control
- 2 Swing arm
- 3 Yarn laying by counter rotating propeller
- 4 Visual display of yarn end and full doff
- 5 Cutter mechanism for single end prevention
- 6 Motorized numbering tension device
- 7 Electronic non-contact yarn sensor
- 8 Balloon thread guide
- 9 Supply package
- 10 Separator
- 11 Pre-tension device

Yarn traversing system

The winding system is outlined by a unique yarn laying principle. Two counter rotating propellers impart gentle handling of the yarn and a highly precision winding is achieved.

As the blades are directly synchronised with the positively driven yarn package, the precision winding is achieved.

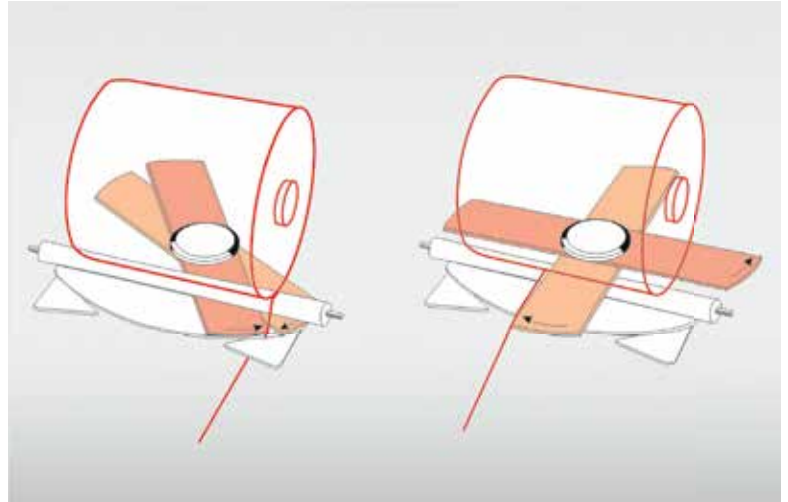

Because of a constant winding ratio from start to the final package diameter, absolutely no ribbon or pattern zone is observed on the produce package. This guarantees excellent unwinding characteristics of the package during the subsequent process.

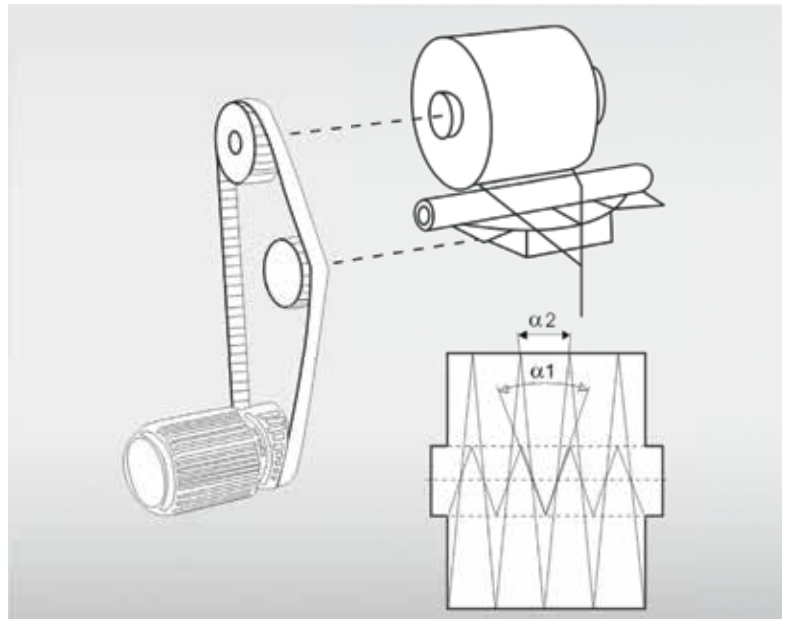

Smart controller

All spindle functions are monitored and controlled by the microprocessor based system which offers following features:

- High definition colour LCD, touch screen 10"
- Individual/group wise speed & length setting
- Storage of last 50 shift's data
- Extendable up to 96 spindles
- Individual spindle maintenance mode

Standard features

- Individual frequency inverter drive
- Constant yarn speed by electronic control
- Auto yarn length controlling device
- Auto stop motion for full doff with visual display
- Motorized numbering tension device
- Diameter control
- Cutter mechanism for single end prevention
- Smart yarn sensor
- CE approved

Optional features

- Online production monitoring system
- Slub catcher on each ply
- Splicer unit
- Overhead travelling blower



Technical specifications

Machine model
PPW-A

Type of winding
Precision winding

Supply package type
All types

Supply package
2ply OD Ø240mm
3ply OD Ø230mm
4ply OD Ø180mm

No. of winding heads
4 to 96 Spindles

Count range
№ 20/2 to 300/2

Produce package type
Cylindrical / Conical

Power
Installed:
0.185 KW / spindle

Machine arrangement
Single sided
Double sided

Package destination
Twisting / Weaving

Produce package diameter
min. ID Ø38mm,
max. OD Ø275mm

Spindle drive
Individual

Spindle gauge
500mm

Winding speed
up to 1200m/min (depending
on process parameters)

Produce package traverse
6"
7" (only available for PV 7*)
8"

Special features
Propeller thread laying
system for lowest yarn
stressing while winding

Layouts

Single side

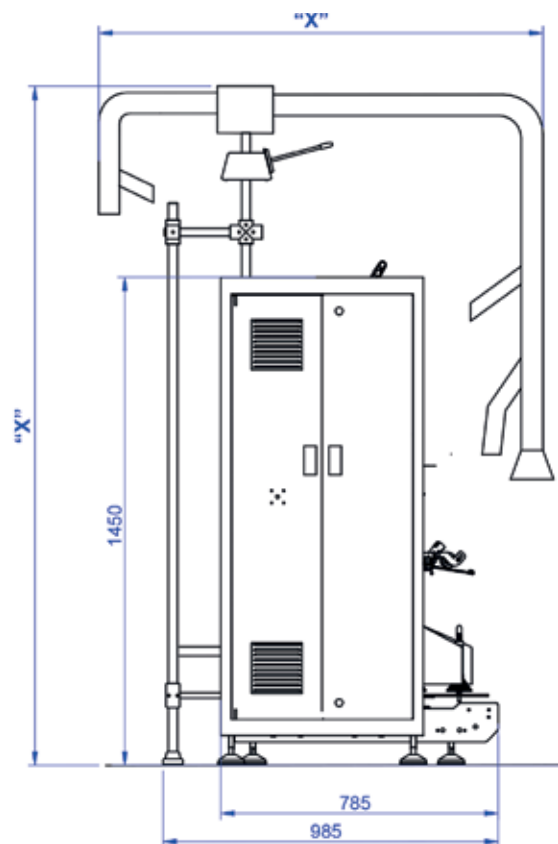

Double sided

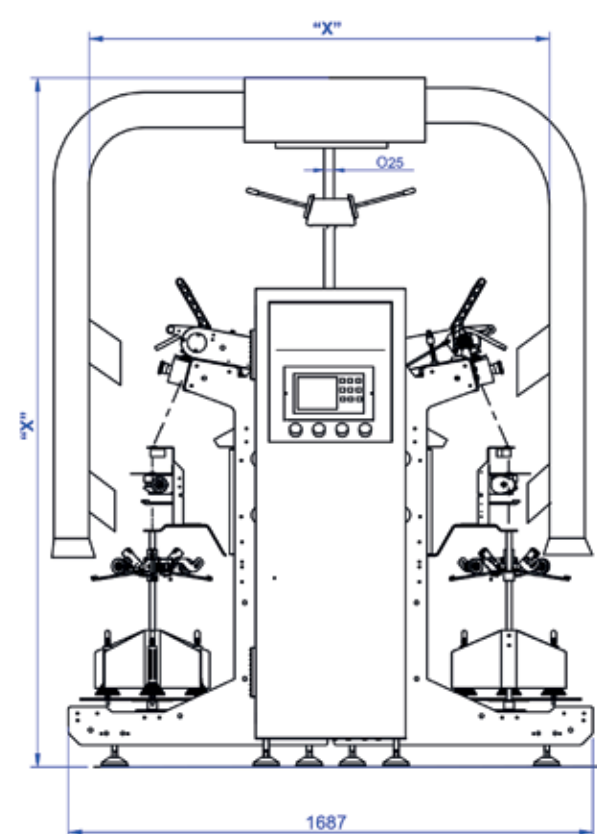

Single and double versions are also existing with outside creel.

"X" = Depending of manufacturer.

Detailed foundation plan on request.



**Allma Volkmann
Zweigniederlassung der
Saurer Germany GmbH & Co. KG**

Weeserweg 60
47804 Krefeld
T +49 2151 717 01
F +49 2151 717 474
sales.volkmann@saurer.com
www.saurer.com

**Saurer Hong Kong
Machinery Co. Ltd.**

Room 2803-5, 28/f, The Center
99 Queen's Road Central
Central
Hong Kong
T +852 2866 0308
F +852 2861 2715
jackson.ye@saurer.com

**Saurer (Jiangsu)
Textile Machinery Co., Ltd.**

Shanghai Branch Company
36F, Tower B, The HQ, 100 Zunyi Road
200051 Shanghai
China
T +86 21 2226 2578
F +86 21 2226 2586
TWI.SH.CN@saurer.com

**Saurer (Jiangsu)
Textile Machinery Co., Ltd.**

No.9, Chang Yang Street
Suzhou Industrial Park, 215024
Jiangsu Province China
T +86 512 8188 5998
F +86 512 8188 5999
info.TWI.CN@saurer.com

Saurer Inc.

8801 South Boulevard
Charlotte, NC 28273
USA
T +1 704 916 42 72
F +1 704 393 15 02
twisting@saurerinc.com

Peass Industrial Engineers Pvt. Ltd.

Regd. Office

Survey No. 303/1f 302/1, Maneklal Road.
Navsari - 396 445 (W.R.) Gujarat, INDIA
T: +91 2637 240843/250811/325101/329419
F: +91 2637 257321
navsari@peass.com

Mumbai Office

Merchant Chambers,
2nd Floor, 41, New Marine Lines,
Mumbai - 400 020 INDIA
T: +91 22 6121 0900
F: +91 22 6631 0570
mumbai@peass.com

Delhi Office

729, Pocket 'E',
Mayur Vihar Phase II,
Delhi - 110 091 INDIA
T: +91 11 2277 3701 | 3244 5102
F: +91 11 2277 4741
delhi@peass.com

Coimbatore Office

P-1, 3rd Floor, Red Rose Plaza,
509, D.B. Road, R.S. Puram,
Coimbatore - 641 002 INDIA
T: +91 422 254 4097 | 324 5115
F: +91 422 254 4097
cbe@peass.com

Ahmedabad Office

Samudra, B-201, 2nd Floor,
Sardar Patel Nagar Road,
Navrangpura,
Ahmedabad - 380 006 INDIA
T: +91 79 2642 7665 | 3293 5112
F: +91 79 2642 7665
ahd@peass.com

Website: www.peass.com