



XR 600

Leaders in twisting technology since 1869

RATTI TWISTING MACHINERY
INDIVIDUAL HEAD TWISTING MACHINE



made in **Italy**

TWO-FOR-ONE TWISTING MACHINE FOR THE PROCESSING OF MEDIUM-HEAVY COUNTS



The **RATTI XR 600** is an individual head two-for-one twisting machine for the processing of medium-heavy counts:

- The machine can be equipped from a minimum of one unit/ 6 spindles up to a maximum of 12 units/ 72 spindles. Each unit, as well as each position, is independent from the others and it is like one individual machine.
- The machine can be equipped with spindles model NT220, NT260, NT280 and NT280-330.
- Pneumatic yarn threading.
- Belt conveyor for an easier take-up bobbin unloading.
- Touch screen to set and control each single position.
- Individual control of spindles, capstan, traverse and take-up speed.
- Machine equipped with automatic tail, individual meter counter and yarn-presence sensors.
- Winding tension of yarn controlled by capstan.
- Machine built according to the last CE standards for quality and safety.



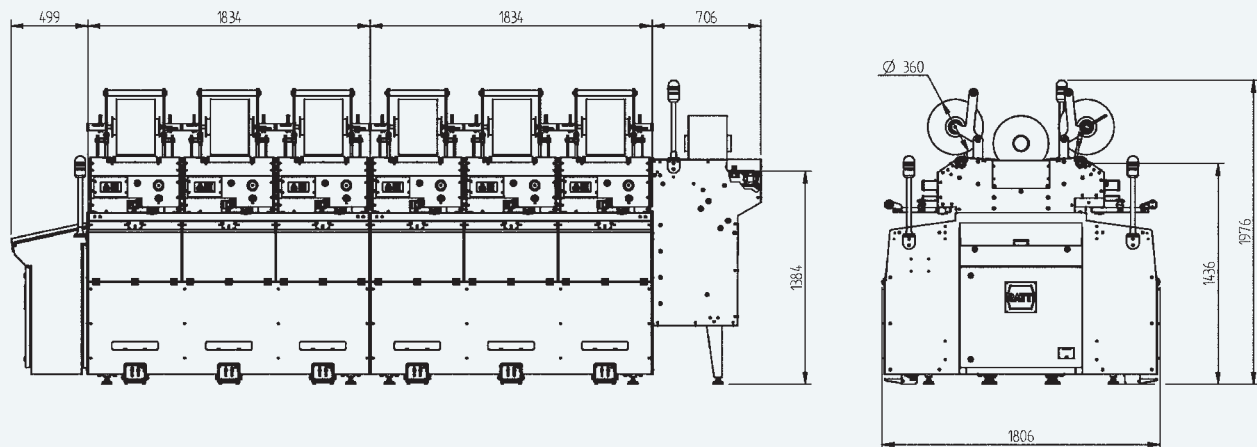

TECHNICAL DATA

MAIN FEATURES

Spindle per section	6	n°
Number of sections	From 1 to 12	n°
Spindle total number	6 x n° of sections	n°
Spindle gauge	610	mm
Traverse system	Electronic	
Counts range	From 167 to 12.000*	Dtex
Drive motors: max. installed power	1,5 + (6,9 x n° of sections)	kW

TAKE - UP

Max. bobbin diameter	360	mm
Initial stroke	250 + tail	mm
Max. tube length at take-up	300	mm
Maximum / minimum mechanical speed	300 / 50	m/min

CAPSTAN

Maximum / minimum mechanical speed	390 / 50	m/min
------------------------------------	----------	-------

FRAME

Section length	1.834	mm
Machine total length	1.205 + (1.834 x n° of sections)	mm
Overall machine width	1.806	mm
Overall machine height	1.976	mm
Take-up height	1.436	mm

*Depending on the spindle model

SPLINDLES TABLE

Spindle type	NT 220	NT260	NT 280	NT 280-330	
Max. spindle speed	8.500	7.500	6.500	6.000	rpm
Min. spindle speed	2.750	2.750	2.750	2.750	rpm
Whorl diameter	42	42	42	42	mm
Type of feeding package	bobbin	bobbin	bobbin	bobbin	
Max. feeding package height	290	290	290	290	mm
Max feeding package diameter	210	250	275	320	mm

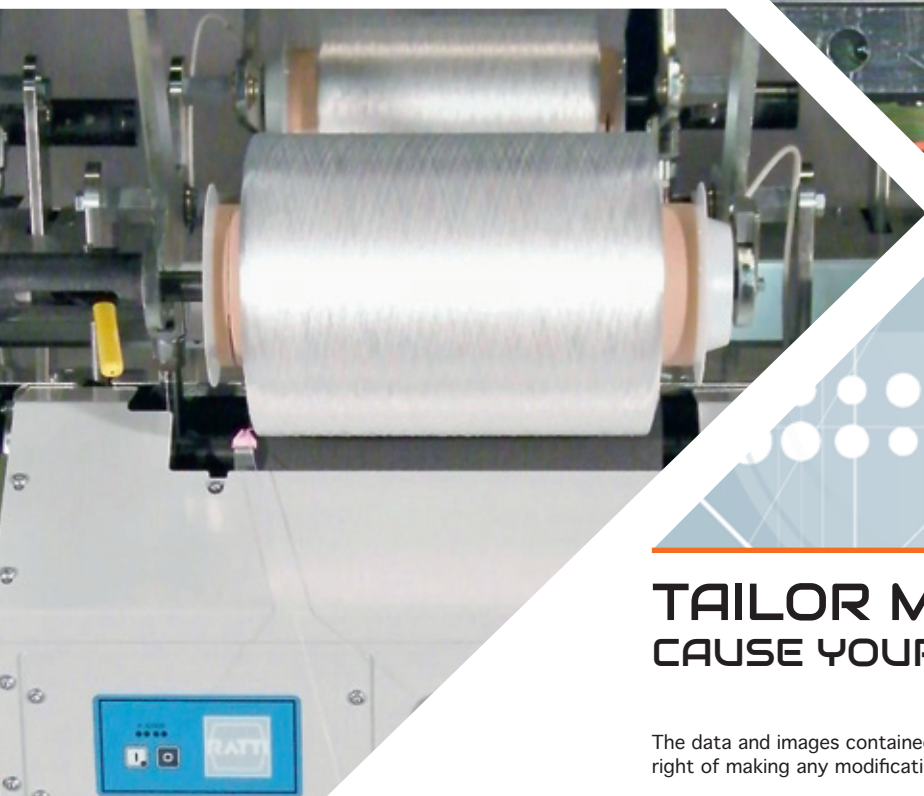

TAILOR MADE MACHINES CAUSE YOUR NEEDS IS OUR JOB!

The data and images contained in this catalogue are indicative. The company reserves the right of making any modifications of technical-construction type without previous notice.



RATTI Luino S.r.l.

Via Provinciale, 309 - 21030 Cassano Valcuvia (VA) - Italy
Phone: +39 0332 538.411 - Fax +39 0332 530.988
info@rattiluino.com - www.rattiluino.com

