

OVERVIEW

GALILEO - FT60 & FT70
ROVING FRAMES

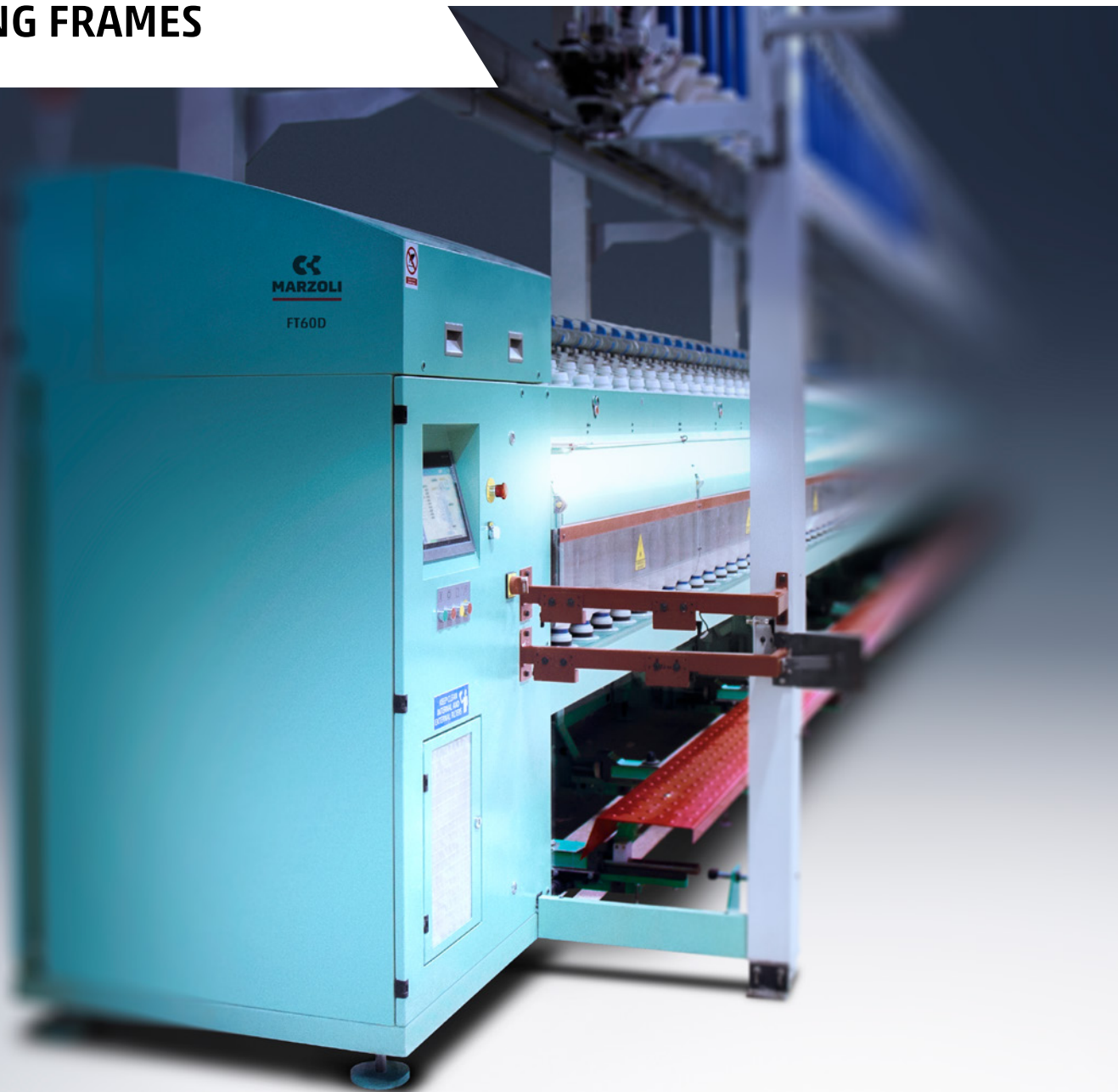

Marzoli

Complete spinning line,
components and digitalized
solutions for the best performance
of the spinning process



THE ONE SOURCE FOR A FULLY-AUTOMATED AND DIGITALIZED SPINNING MILL

Marzoli, one of the major brands of the textile sector worldwide, is a unique European manufacturer of the complete line of machines for the opening, preparation and spinning of short-staple fiber. From the bale opener to the ring spinning frame, Marzoli offers the most advanced technology for a completely-automated spinning mill. Through its global sales and service network, its expertise on each type of fiber and application and the competence on the entire process, Marzoli represents a competent and reliable partner. And through its experience, know-how and commitment, it provides its customers with:

- Advanced spinning solutions through a careful activity of textile engineering. Marzoli assists its customers from the study of the spinning plan, throughout sourcing, erection and commissioning, up to maintenance of the resulting turnkey spinning plant, which can comprise Marzoli but also third-party machinery. The customer can rely on the competence and capability of a unique partner, responsible for the quality and productivity of the entire spinning mill.
- The advantages of smart spinning. No matter what the brand(s) of the machinery is, Marzoli can install its software platforms, YarNet and MRM, its hardware applications for gathering data on waste percentages and its composition, quality values, productivity indexes and other kpi data to let the customer build on the potential of Industry 4.0, optimize the entire spinning process through well-informed decisions and reach the highest performance in production operations.

OVER
160 YEARS
OF SUCCESSES

OVER
70 COUNTRIES
WITH ACTIVE CLIENTS



OPENING SECTION

- Openers & Cleaners
- Mixers & Blenders
- Card

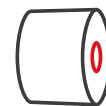

COMBING SECTION

- Draw Frames
- Lap Winder
- Comber
- Lap Transport



SPINNING SECTION

- Roving Frame
- Ring Spinning Frame
- Bobbin Transport System

GALILEO - THE FT60 & FT70 ROVING FRAMES

Productivity, efficiency and versatility

KEY POINTS

- SUPERIOR TECHNOLOGY
- OUTSTANDING PRODUCTIVITY
- LOW INVESTMENT AND OPERATIONAL COSTS
- FAST RETURN ON THE INVESTMENT
- TOP QUALITY ROVING
- COMPLETE RANGE FOR ALL MARKET REQUESTS



Ever since the conception of its market-leading roving frames, the FT6 and the FT7, Marzoli has never stopped to search for innovative ways to further improve its outstanding technology. It is thanks to this extensive research activity and the continuous effort of its highly competent technical department, that Marzoli presents the FT60 and the FT70. These roving frames are equipped with all the most-advanced technologies along with Marzoli's latest innovations, and represent technological excellence for productivity, efficiency and versatility.

All the electronic drives for the drafting system, the flyers, the spindles and the bobbins rail are coordinated by the central CPU which simplifies the machine, guarantees a perfect coordination of all the movements involved in bobbin formation, reduces the number of components, lowers friction, vibrations and mechanical wear, with substantial savings on energy consumption and maintenance.

The number of spindles, the FT60 and FT70 can respectively reach 240 and 192 spindles, the space rationalization, enabled by a smaller and more accessible head-stock, and thinner tubes, 48 mm instead of the standard 53.5 mm, have enabled the FT60 and FT70 roving frames to grant the following benefits:

• **Higher productivity.**

The client can produce more roving with the same number of machines, thanks to the higher number of spindles; he can produce more roving with the same number of spindles, thanks to the tubes with smaller diameter which allow to host more roving per bobbin and therefore reduce the number of doffing cycles; he can produce more roving in a given space, thanks to the 110 mm gauge between the spindles and the smaller and more accessible head-stock.

• **Investment savings.**

Thanks to the higher production of the FT60 and FT70 roving frames, underpinned by a higher

number of spindles, the client can purchase a lower number of machines in order to reach the desired production level and fewer machines entail lower investment costs because they require fewer head and rear stocks, fewer cleaners and bobbin exchangers, fewer blowers, optimized transport rail's length, etc.

- **Lower operational costs.**

Because there are fewer machines, the cost for their maintenance is lower. Moreover, thanks to a more productive space utilization, the customer can also lower the incidence of fixed costs on the roving and on the yarn being produced: as the client can install fewer roving frames and still obtain the same production level, he can reduce the installation space and all the related fixed costs (conditioning, lighting, rents, etc.).

Moreover, the FT60 and FT70 roving frames also eliminate the operational costs related to suction. On standard roving frames with one photocell, suction is required in order to capture the broken roving which is then detected by the sensor that stops the machine. On Marzoli's roving frames the broken roving is immediately detected by special sensors and does not need to be captured by the suction nozzles. Suction is therefore no longer required and the client can draw on substantial energy savings, 4 Kw per hour.

The FT60 and FT70 roving frames also excel on versatility as they have been designed in order to meet any customer request:

- Semiautomatic or automatic doffing (doffing time less than 3 minutes);
- **Up to 240 spindles**, gauge 110mm, 6"x16" bobbins with the FT60 or **up to 192 spindles**, gauge 130mm, 6" or 7"x16" bobbins with the FT70;
- 3 over 3 or 4 over 4 drafting unit;
- Mechanical or electronic draft;
- Cylinders diameters of either 32 mm or 27 mm (for a lower gauge between first and second cylinders and a better control of short fibers in the drafting area);
- Pneumatic or mechanical pressure arms;

- Bobbin tube diameter 53.5 mm or 48 mm for more roving per tube;
- Individual sensors for roving breakage (option);
- Control sensor of roving tension (option);
- Bobbin exchanger installed on either the head or the rear stock;
- **Integrated Bobbin Cleaner (IBC) (option);**
- **Integrated Transport System (MTR/MTT) (option);**
- State-of-the-art electronics;
- **Marzoli Remote Maintenance (option);**
- Data Collector, Power Management System, Production management software (**YarNet) (option).**

The FT60 and FT70 roving frames, thanks to their special ergonomics, perfectly integrate in existing plants. In these cases, Marzoli proposes customer-tailored solutions by analyzing the layout and the client's production needs through a careful engineering activity. The FT60 and FT70 roving frames allow to obtain a substantial optimization of the available space granting higher productivity and guaranteeing a rapid return on the investment thanks to lower energy consumption and maintenance costs.



SUPERIOR PERFORMANCES THROUGHOUT THE ENTIRE SPINNING SECTION

KEY POINTS

- FULL MECHANICAL AND LOGICAL INTEGRATION OF THE SPINNING UNIT
- FULL AUTOMATION AND TOTAL FLEXIBILITY
- SUPERIOR EFFICIENCY THROUGHOUT THE SPINNING SECTION
- TROUBLE-FREE PRODUCTION MANAGEMENT



With the FT60 and FT70 roving frames, Marzoli does not only offer a product of excellent quality, efficiency and outstanding productivity, but also aims at innovating the very concept of **spinning section** (roving frame, bobbin transport system and spinning frame).

In fact, the FT60 and FT70 roving frames are based on an innovative engineering concept of **full mechanical and logical integration of every machine of the spinning unit**. From the mechanical point of view, the empty trains of Marzoli block creeling transport system (MTT) can access the doffer rail of the FT60 and FT70 roving frames and, after having been loaded with full roving bobbins, they are sent to a parking station where an exchanger loads the bobbins on new trains that can enter the creel of any spinning frame installed inside the plant.

No human operation, beside roving piecing at the spinning frame, is required. This guarantees full automation, no poor handling of the roving bobbins and top flexibility as the trains can enter any roving

frame and can be sent to any spinning frame.

The electronic draft installed on the FT60 and FT70 roving frames allows an easy setup of the machine without any mechanical modification: this further boosts the flexibility of the FT60 and FT70 roving frames that hence represent the perfect solution for spinning mills with flexible production programs and with frequent changes in production lots.

These mechanical innovations disclose all their potential in terms of superior flexibility and efficiency of the spinning section, thanks to the logical integration of the unit, achieved through the implementation, for the first time ever in the textile industry, of the technological paradigms of Machine-to-Machine (M2M) and Machine-to-Human (M2H).

Marzoli has developed two innovative platforms, YarNet and Marzoli Remote Maintenance (MRM), that allow to easily control and manage the entire spinning mill.

The first platform, YarNet, allows to continuously monitor real-time production data, operating conditions and statuses of each machine: everything, from the kilograms per hour being produced to the energy consumption level, from the number of roving breakages to the waits and stops causes, can be accurately monitored in real time by the client on his computer. Moreover, YarNet also allows to download, modify, create from scratch and send new production recipes to every machine. Once the new production recipe has been sent to a machine, the user can decide to start the new lot production automatically after the next doffing or to send a signal on the machine panel. In the latter case, the operator at the machine will decide if and when to start the production of the new lot. The second platform, Marzoli Remote Maintenance (MRM), is an innovative service that draws on diagnostic technology installed inside the machines in order to continuously monitor the state of health of critical parts. If there are any parameters (temperatures, vibrations, etc.) that are outside the nominal operating ranges, the client is alerted so that maintenance operations can be undertaken before the situation worsens. All together the mechanical innovations and the two Marzoli platforms allow to implement the innovative paradigm of superior integration of the spinning unit which grants to the client the following benefits:

- **Total flexibility.**

The client, thanks to YarNet, can easily set any production recipe or recall it, if already used and saved on his computer, he can send it to any roving frame and start its production automatically thanks to the electronic draft. Then, through Marzoli Block creeling transport that enters the doffer rail, the bobbins can be collected and transported, without any human intervention, from the roving frame into the creel of the desired spinning frame. This outstanding level of flexibility allows to easily meet any customer request and to easily and quickly undertake maintenance operations. In fact, in case the client needs to balance the production of a particular count of roving, he can easily change the production recipe of any roving frame.

- **Superior efficiency of the spinning unit.**

YarNet allows to easily monitor energy consumption, roving and yarn breakages, the number of roving bobbins on the transport system, etc. It also allows to modify the production and the speed of the roving frames on the basis of this information in order to optimize efficiency levels, lower waste percentages, and boost productivity of the entire spinning unit. For instance the operator using YarNet can easily verify if there is an increasing number of full roving bobbins on the transport system and adapt the speed of the roving frames in order to save energy.

- **Total transparency.**

The entire manufacturing process is carefully monitored through continuous data and information processing, therefore, if there was any kind of problem, the system would immediately alert the operator and maintenance teams could draw on a great amount of relevant and reliable information in order to undertake effective maintenance. In fact, thanks to MRM, the problem is immediately identified and localized: the maintenance team knows exactly where the problem is and what the possible reason might be.



MACHINE DESCRIPTION

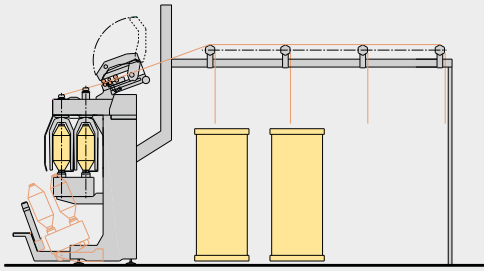

Roving frame with semiautomatic doffing

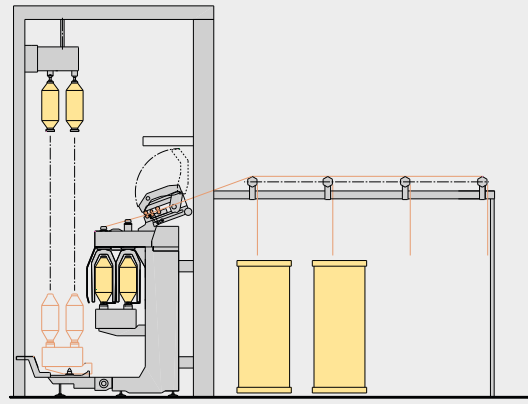

Roving frame with automatic doffing

TECHNICAL DESCRIPTION | LEGEND

- 1 Supports and doffing columns
- 2 Exchanger
- 3 Doffer rail
- 4 Intermediate leg
- 5 Flyers rail
- 6 Bobbins rail
- 7 Bobbins motor
- 8 Flyers motor
- 9 Bobbin
- 10 Cylinder
- 11 Pressure arm
- 12 Sensors for roving breakages
- 13 Suction ducts if installed
- 14 Integrated bobbin cleaner

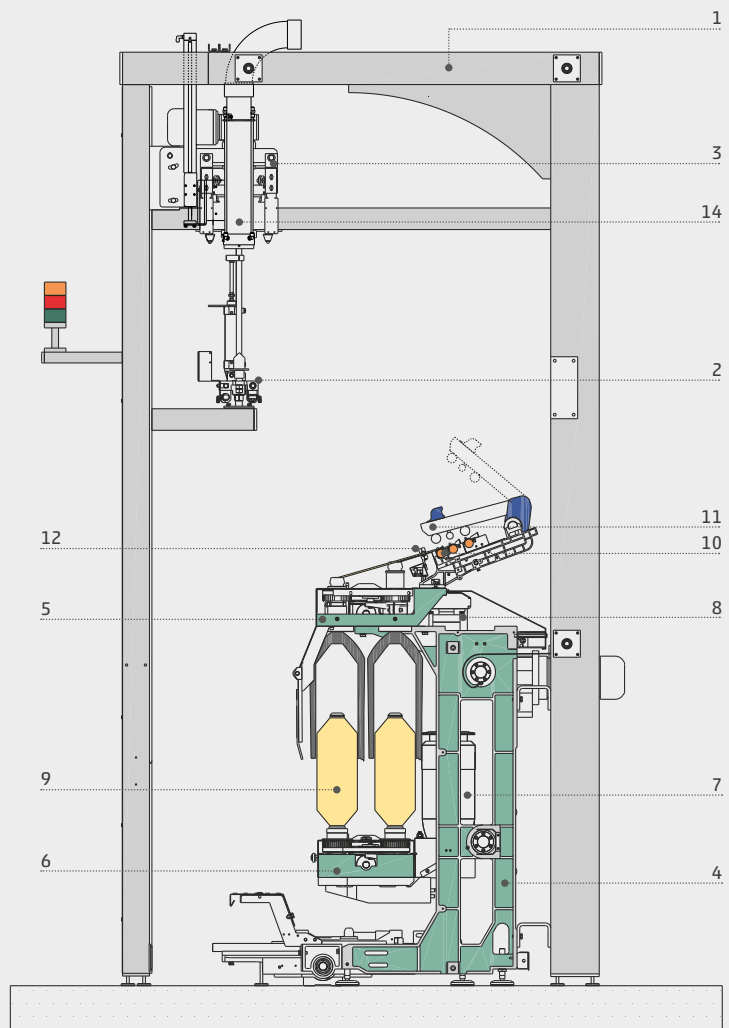
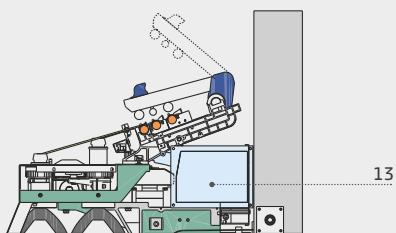

INDEPENDENT MULTI-MOTOR DRIVE

Perfect synchronization of all working organs

The FT60 and FT70 roving frames draw on the most advanced and reliable electronics in order to perfectly synchronize all the independent motors driving the working organs (spindles, flyers, bobbins rail and drafting unit).

Mechanical transmission is, therefore, reduced and this grants the following benefits:

- High speed and high quality roving thanks to the elimination of uncontrolled vibrations.
- Low energy consumption thanks to the reduction of mechanical friction.
- High reliability because of the fewer components and the reduced mechanical wear.
- High flexibility because the machine can be easily set electronically through the touch screen interface without any mechanical modification (gears change).

Driving system

The spindles and the flyers drives of the **FT60 roving frame** include:

- One high efficiency motor every 32 flyers
- One high efficiency motor every 32 spindles

FT70 roving frame include:

- One high efficiency motor every 24 flyers
- One high efficiency motor every 24 spindles

This configuration allows to:

- Reduce energy consumption.
- Obtain a higher efficiency of the transmission system.
- Increase reliability.
- Reduce the noise of the machine thanks to the elimination of gear boxes to drive the flyers.
- Reduce maintenance.

All spindles motors are controlled by one drive.

On the long machine, over 192 spindles (FT60) / over 144 spindles (FT70), the drives are two.

KEY POINTS

- REDUCED POWER CONSUMPTION
- REDUCED VIBRATIONS AND FRICTION
- LOWER MAINTENANCE
- LOW NOISE

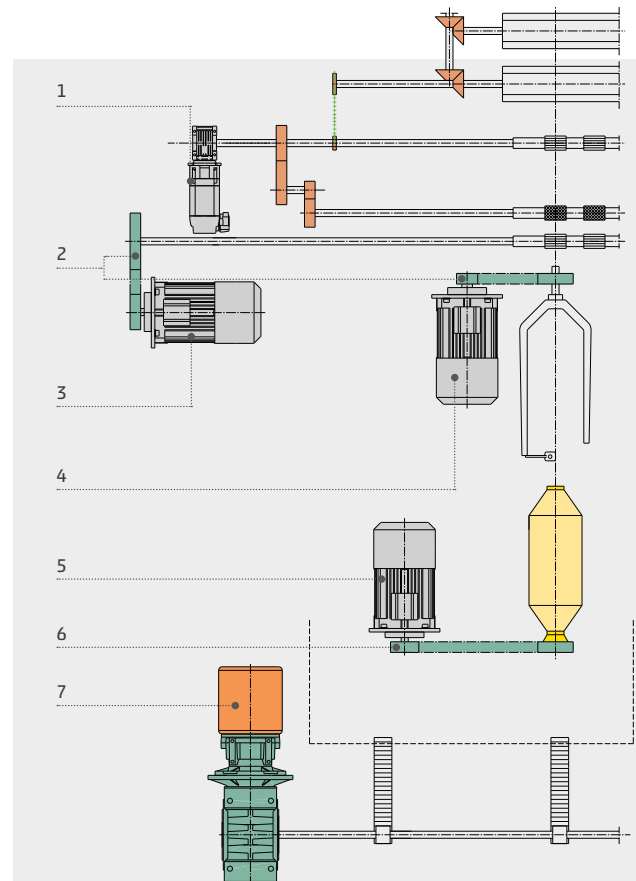

MACHINE DESCRIPTION - CAPTION

- | | | | |
|---|--|---|----------------------------|
| 1 | Brushless for second and third cylinders | 4 | Flyers motor |
| 2 | Timing belt | 5 | Spindles motor |
| 3 | Motor for first cylinder | 6 | Timing belt |
| | | 7 | Brushless for bobbins rail |



FT60 & FT70 DRAFTING SYSTEM

High flexibility & top quality

Marzoli offers several options for the configuration of the drafting area of the FT60 and FT70 roving frames.

The customer can choose between:

- Mechanical or electronic drive.
- Auxiliary drive for long machine or special man made fibers.
- Three or four drafting cylinders.
- 32 mm or 27 mm cylinders diameters.
- Pneumatic or mechanical pressure arms.
- Two options of cleaning device for the top rollers.

Electronic draft

The FT60 and FT70 roving frames can be equipped with an electronic drive which allows the customer to directly set the desired draft from the touch screen display without any mechanical modification.

This grants the following benefits to the client:

- Simple and fast set up of the desired draft.
- Great flexibility.
- Perfect accuracy in the implementation of the desired draft.
- Reduced machine downtime.
- Great ease of use.
- Reduced noise.
- Reduced maintenance.
- Full control of the roving frame through YarNet.

Auxiliary drafting drive

Marzoli offers an auxiliary drafting drive to avoid any vibration and reduce torque and torsion of the drafting rollers on extra long roving frames or when spinning man made fibers that are hard to draft.

This driving box is located in the tail stock.

KEY POINTS

- SEVERAL OPTIONS FOR THE DRAFTING AREA
- SIMPLE & FAST SET UP OF THE DRAFT
- PERFECT ACCURACY IN THE IMPLEMENTATION OF THE DESIRED DRAFT
- TOP DRAFTING PERFORMANCES & PERFECT CONTROL OF THE FIBERS
- PREVENTION OF ROVING OVERLAPPING

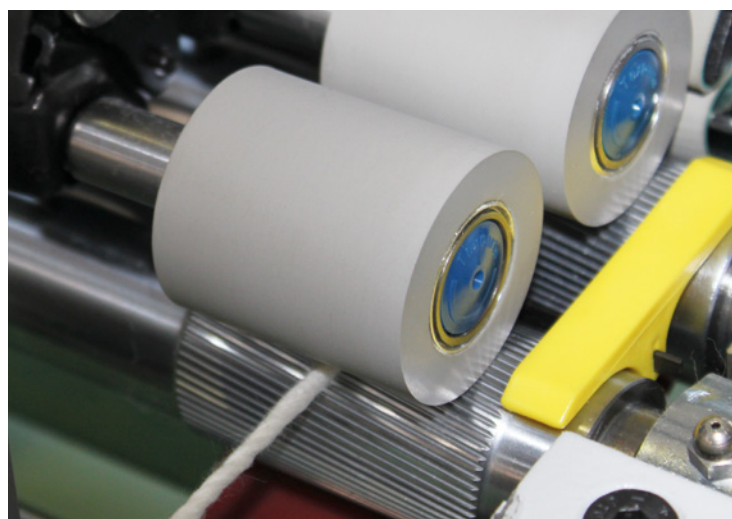
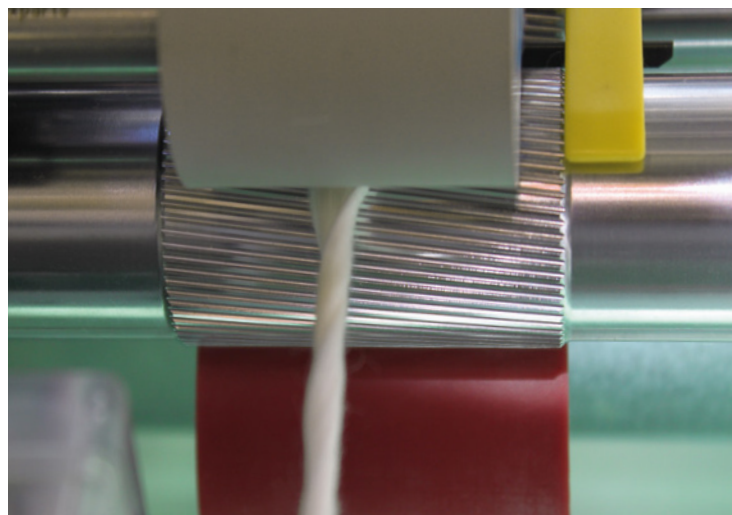

Pressure arm

The drafting system of the FT60 and FT70 roving frames ensures a constant load for every spinning position for a uniform control and a perfect draft of the sliver. Its configuration can be mechanical or pneumatic. In the latter case the pressure is generated through a close-circuit compressed-air system; every arm is linked by connection hose to the centralized air supply system.

Bottom roller cleaner

An individual hard rubber scraper placed below the bottom roller ensures their perfect cleaning at each spinning position. This ensures a perfect control of the fibers and prevents overlapping of the roving.

Top Rollers cleaners

For the top rollers cleaners Marzoli offers two options: top rollers cleaners with rubber fins (*See Figure A*); individual top cleaners with revolving felt belt (*See Figure B*). Both solutions ensure an effective, simple and easy cleaning of the top rollers. The latter option also undertakes a self-cleaning action in order to constantly guarantee the highest performances of the top rollers. This solution comprises a felt belt which revolves over the top rollers, positively driven. Each belt is regularly cleaned by a special scraper; the cotton waste accumulated in its proximity is then sucked by the overhead cleaner.



Figure A



Figure B

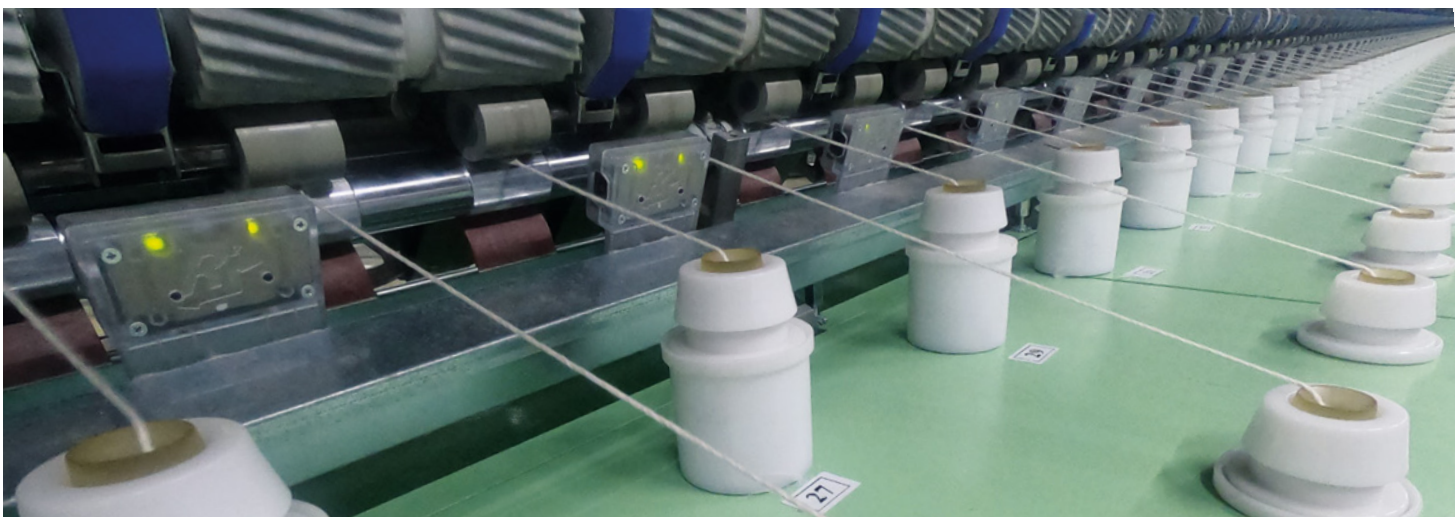

INNOVATIONS ON COMPONENTS

Smart solutions to boost efficiency & productivity

Marzoli has always dedicated great attention to every detail of its machines and, from the meticulous design of each component and the drive towards continuous innovation, some simple but effective solutions to boost efficiency and productivity have been found.

Automatic piecing-up after doffing

Thanks to a velcro strip located on the top of the tubes Marzoli roving frames can perform an automatic piecing-up of the roving when restarting production after doffing.

Tube diameter of 48 mm

Possibility to use tubes with diameters of 48 mm, instead of standard tubes with diameters of 53.5 mm. This solution allows to increase the amount of roving on the tube and therefore reduces the number of doffing cycles, boosts productivity of the roving frame and reduces the bobbin changes at the spinning frame.

Hexagonal aluminum creel rollers & sensors to detect sliver breakages

The feeding creel can be equipped with four, five or six rows of cans of 20" or 24" of diameter. The positively driven creel, made of four, five or six rollers with hexagonal shape, prevents false drafts of the slivers. A set of photocell sensors immediately detects any possible breakage of the slivers and promptly stops the machine.

The FT60 and FT70 roving frames are equipped with a settable creel. The aluminum rollers position can be longitudinally set while the supports can be vertically adjusted in order to change the height of the creel and facilitate the access to the slivers feeding area.

KEY POINTS

- AUTOMATIC PIECING-UP OF THE ROVING AFTER DOFFING
- THINNER TUBES FOR HIGHER BOBBIN CAPACITY
- HEXAGONAL CREEL ROLLERS TO PREVENT SLIVER FALSE DRAFTS
- IMMEDIATE STOP OF THE MACHINE IN CASE OF SLIVER /ROVING BREAKAGE

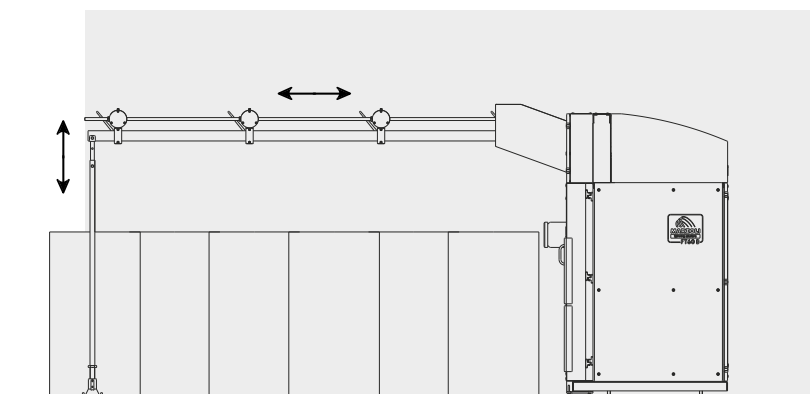
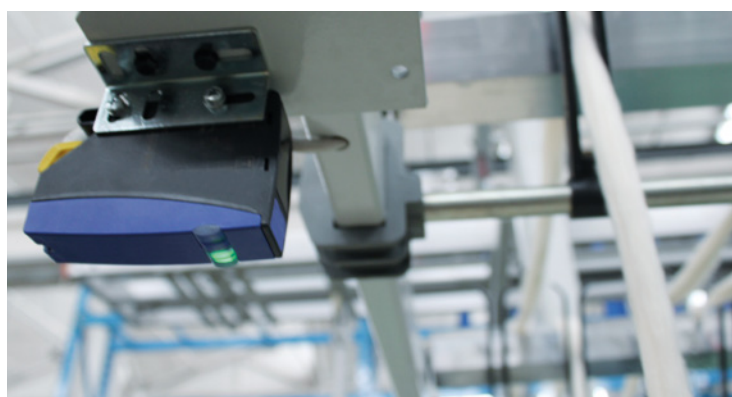
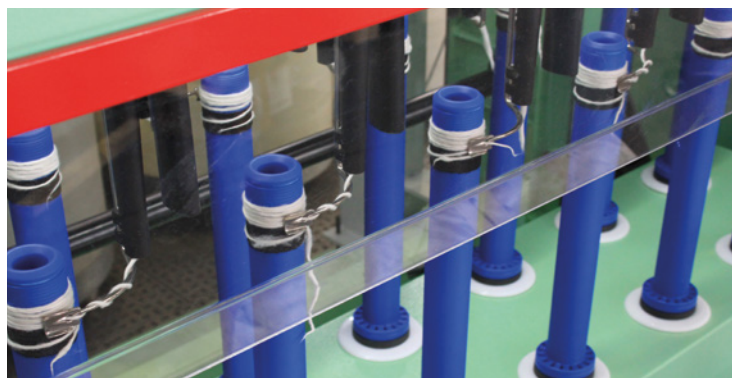

Individual sensors to detect any roving breakage

Marzoli roving frames are equipped with special sensors, one for each spinning position, that allow to immediately identify any roving breakage and to promptly stop the machine. These sensors overturn the way photocells on competing machines work: competing machines stop if the photocell detects the presence of a (broken) roving whereas Marzoli roving frames stop if any individual sensor detects the absence of the roving.

This discloses the following advantages:

- In case of overlapping of any roving, unlike the single photocell, the individual sensors guarantee the machine stop, avoiding waste of roving and damages to the drafting cylinders.
- In case dust passed in front of the sensors, the machine would continue to work, whereas in competing solutions the machine would stop with loss of production and the request of the operator's intervention.
- Suction is no longer required. In order to let the photocell detect the broken roving, suction systems are needed to guide the roving in front of the photocell. Thanks to the individual sensors Marzoli roving frames can work without suction, allowing the client to save 4 Kwh during roving operations.

These sensors allow to calculate the total number of roving breakages per spindle during a formation cycle or a preset period of time (e.g. a day, a week, etc.). This allows the client to immediately identify

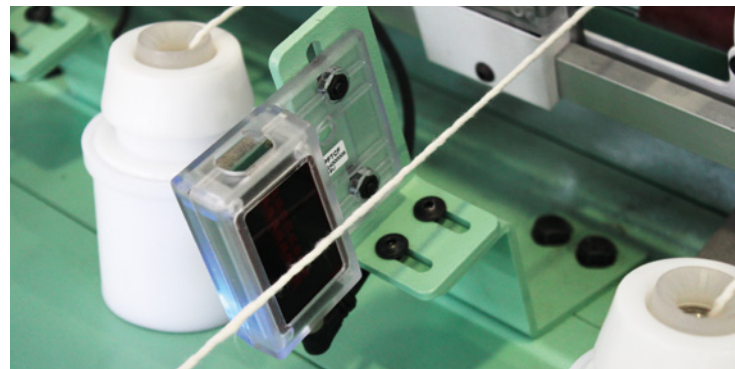

malfunctions on particular spindles and undertake well-aimed maintenance operations in order to boost productivity with the minimum machine downtimes.

Integrated sensor for roving tension control

Marzoli integrated sensor for roving tension constantly monitors the fluctuations of the roving in order to evaluate its tension. If the device detects an average tension outside the preset parameters, it adjusts the speed of the spindles in order to bring back the value inside the desired range.

USER-FRIENDLY INTERFACE

The FT60 and FT70 roving frames are managed by a modern PC microprocessor: all the production data and working parameters are controlled and saved during the production cycle.

The multi-language touch screen is user-friendly and permits a simple use with clear diagrams, detailed monitoring pages and step by step troubleshooting procedures.

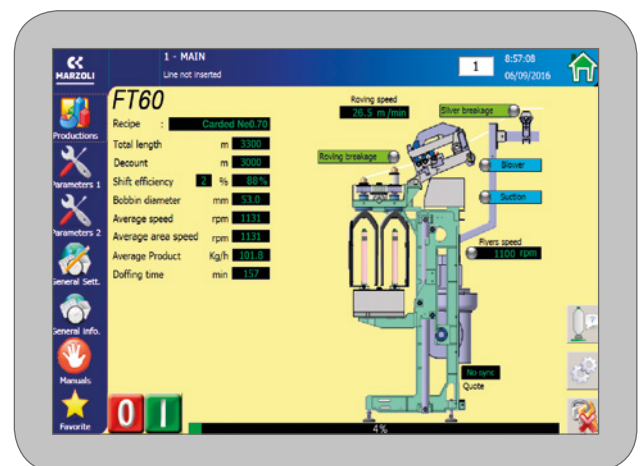

SEMIAUTOMATIC DOFFING AND AUTOMATIC DOFFING

Semiautomatic Doffing

Marzoli machines are equipped with a very fast, ergonomic and reliable semiautomatic doffing system. When the machine reaches the preset length, the bobbin rail goes down and tilts out to give an easy access to the full bobbins.

The operator replaces the bobbins with empty tubes, located in the parking rail. Then the bobbin rail tilts back and the machine restarts automatically.

Automatic Doffing

A high efficient and reliable automatic doffing meets customer expectations with no human intervention. After the machine stops, the bobbin rail with empty tubes comes down and meanwhile the bobbin rail slides out horizontally. When the doffer rail takes all the full bobbins, it goes up with full and empty tubes then it moves one position forward and comes down again. After leaving empty tubes on the spindles the doffer rail goes all the way up. The bobbin rail moves back and the roving frame restarts automatically.

KEY POINTS

- EASY AND FAST SEMIAUTOMATIC DOFFING
- NO HUMAN INTERVENTION IN AUTOMATIC DOFFING
- HIGH RELIABILITY



MARZOLI TRANSPORT SYSTEMS

In order to ensure the highest efficiency level in internal logistics Marzoli has launched its own-branded bobbin transport systems:

- The MTR – Marzoli Random Creeling Solution: the bobbins are carried by a closed circuit overhead chain along the aisles between the spinning frames.
- The MTT – Marzoli Block Creeling Solution: the full roving bobbins are brought to the reserve row located on both sides of the spinning frame or directly inside the creel by trolley trains (one train per creel row).

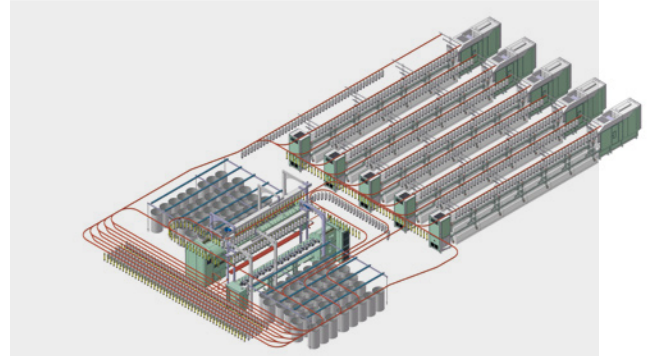
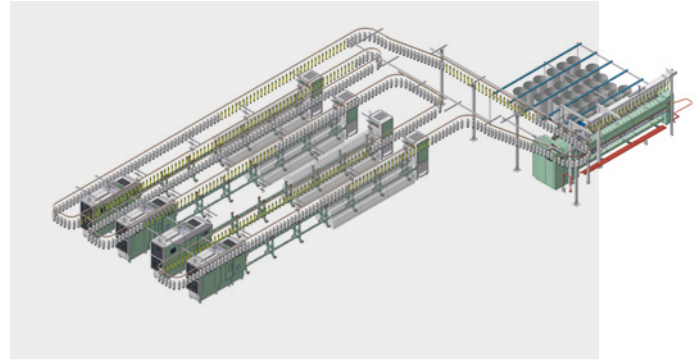

■ MARZOLI IBC

Bobbin stripper integrated on the exchanger, the IBC gives the spinner the following benefits:

- lower investment and maintenance costs: a separated bobbin stripper is no longer necessary
- Reduced cleaning time (< 10 s for 2 layers on the tube) and fewer stops of the chain to boost the efficiency of the entire spinning section.
- Less strain on the tubes holders as each tube is taken only once for both cleaning and exchanging operations



■ MARZOLI MRE

MRE (Marzoli patent) is a new solution to boost efficiency on the operations of exchanging and cleaning of empty tubes. With Marzoli MRE two full bobbins and two tubes are taken simultaneously from the doffer rail and the transport rail. After an intermediate step in which the tubes are cleaned by two integrated IBCs, Marzoli MRE places the empty tubes on the doffer rail and the full bobbins on the transport rail. With this system the process can be done two times faster than single exchangers

(cleaning and exchanging of 240 bobbins /hour), an aspect that can underpin higher efficiency rates on long roving frames and/or when coarse counts are produced. Marzoli MRE can be installed on roving frames of either 110mm or 130mm and exchange bobbins with transport systems with any of the main available gauges.

It can be installed on either the head or the tail stock to save on transport systems and IBC suction ducts.

MORE PRODUCTION IN LESS SPACE

Outstanding productivity thanks
to Marzoli roving frames

KEY POINTS

- MAXIMIZATION OF THE NUMBER OF SPINDLES PER SQUARE METER
- HIGHER PRODUCTIVITY (HIGHER Kg/sqm RATIO)
- GAUGE OF 110 MM BETWEEN THE SPINDLES



The innovative design of the FT60 and FT70 roving frames guarantees outstanding productivity levels. Thanks to the long machine, up to 240 spindles for the FT60 and up to 192 spindles for the FT70, the client can reach the same number of spindles, and thus produce the same amount of roving, with fewer machines. This entails fewer head stocks, fewer rear stocks, fewer blowers, etc. which imply substantial investment savings and a significant advantage in terms of required space for the installation. The gauge of 110 mm between the spindles and the very compact head and rear stocks allow to maximize the number of spindles per square meter and thus a substantial increase in productivity. To produce more roving, the client needs less space and this entails advantages for clients that want to make a new investment as well as for clients that want to substitute old machines:

- For the clients that want to start a new spinning plant, the optimization of the required space grants relevant cost savings: lower rents, savings on lighting and conditioning, etc. Fewer machines also allow to reduce maintenance costs. All these savings ultimately reduce the client's production cost thereby enhancing his product competitiveness and the margins that he can obtain from the market.
- For the clients that already have a spinning mill and want to substitute old machines with new ones the boost in productivity is even greater: the low gauge between the spindles (110 mm) adds up to the smaller head and rear stocks of the new FT60 and FT70 roving frames entailing a substantial increase in the number of operating spindles. The following examples demonstrate how the space occupied by previous models of roving frames can be better exploited with the installation of Marzoli's roving frames.

Example 1

An old roving frame with 120 spindles (gauge 130 mm) can be substituted with a FT60 with 160 spindles (gauge 110 mm). This allows to increase production by 30%. Alternatively, the client can substitute its old machine with two FT60 roving frames, one with 64 spindles and the other with 80 spindles.

This solution perfectly suits clients that want to implement more varied production programs: beside increasing the number of spindles by 20%, this solution also injects a great deal of flexibility in the spinning mill.

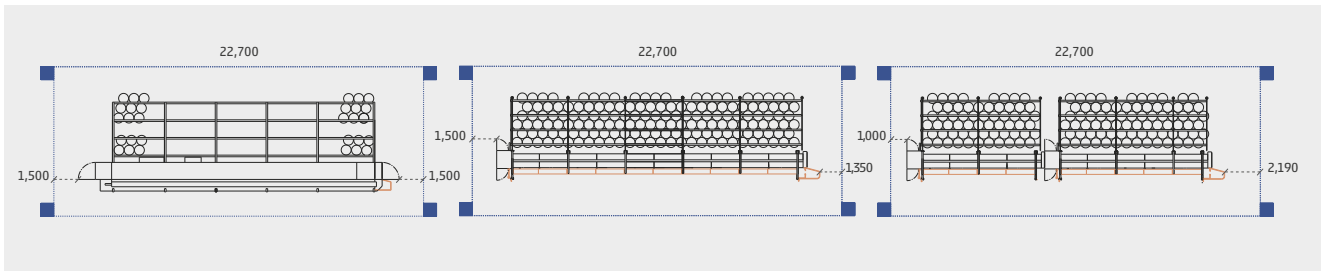
**Example 2**

Substitution of a roving frame with 144 spindles (gauge 130 mm) with one FT60 with 208 spindles (gauge 110 mm).

This investment allows to increase production by almost 40%.

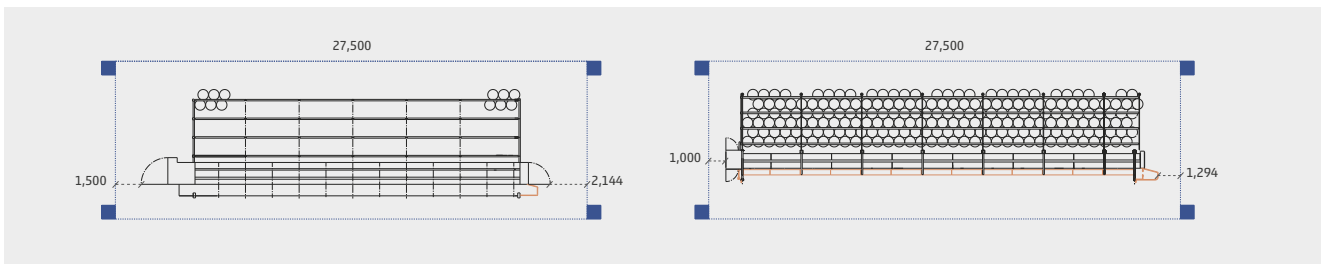
**Example 3**

Substitution of two machines with 192 spindles (gauge 130 mm) with two FT60 (gauge 110 mm) with 240 spindles each. This solution allows to increase productivity by 15% and also to save

space that can be used for other purposes, for example for the parking zone of Marzoli Block Creeling Transport System (MTT).

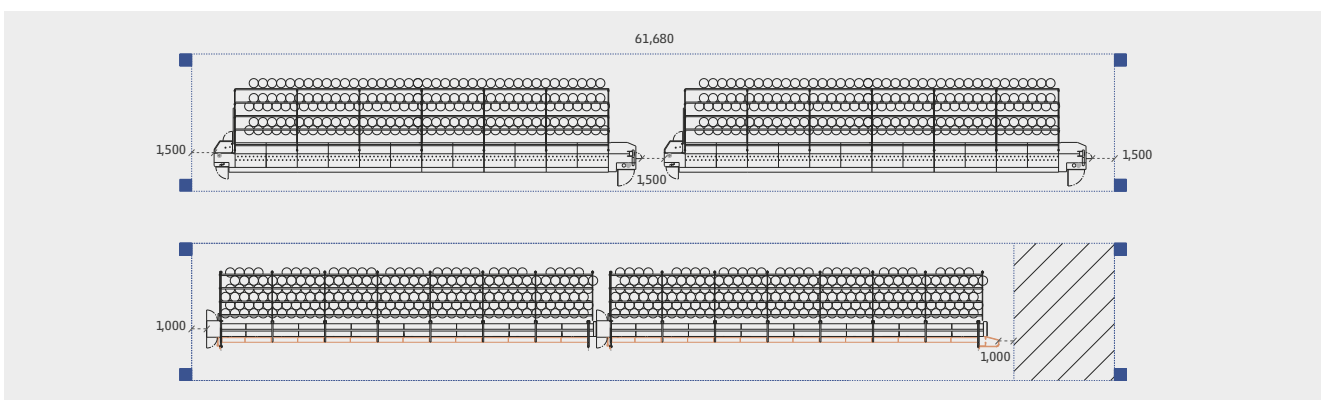

ENERGY EFFICIENCY

Thanks to Marzoli's firm predisposition towards innovation and thanks to the close collaboration with Siemens Textile Machines (Drive Technology Division), Marzoli sets the lead in the development of machines of outstanding efficiency.

The multi-axis technology of the SINAMICS Servodrives has permitted to redesign the electrical cabinet and minimize the required space. Cabling and electromechanical components have been reduced with consequent lower electrical required maintenance. Marzoli's R&D Engineers have undertaken detailed studies of the hot air flows, realized thermal maps and carried out test sessions in order to further improve the already-high cabinet cooling efficiency.

The configuration of motors modules, connected to a common DC bus and fed by a Line Module guarantees a high degree of reliability and ruggedness, even when the quality of the power line is poor. This feature is of special significance for the roving frame as it allows to avoid roving breakages during dips and power failures with all the consequent production downtime.

Thanks to the common DC-Link it is possible to realize energy compensation between drive modules during every phase of bobbin formation. The high dynamic brushless motor driving the bobbins rail allows to achieve high precision and to transform the regenerative power through the DC-Link during the vertical up and down cycles with great energy savings. The mechanical transmission elements are well protected as the torques of the individual motors in the coupled drive train can be flexibly distributed.

KEY POINTS

- OUTSTANDING ENERGETIC PERFORMANCES
- LOWER ELECTRICAL MAINTENANCE REQUIRED
- HIGH DEGREE OF RELIABILITY AND RUGGEDNESS
- POSSIBILITY OF ENERGY COMPENSATION BETWEEN DRIVE MODULES
- EFFICIENCY IMPROVEMENTS UP TO 5%

The fact that the components are fully integrated via a fieldbus allows a whole series of internal drive parameters to be displayed on the touch screen interface where they can be easily monitored.

IE3 asynchronous motors

Marzoli R&D engineers have paid great attention to the proper sizing of asynchronous motors in order to adapt them to real operating conditions. Standard AC-induction motors are equipped with axial fan and textile fan cowl. These motors are simple, with a high ruggedness and lower maintenance requirements. At the same time the integration with advanced Servo drives allows to obtain the best dynamics performances and a precise speed control. **Marzoli for its FT60 and FT70 roving frames installs the new generation of Premium efficiency motors (IE3 class) with improvements on efficiency standards up to 5% compared to standard motors.**

Low friction bearings

A key objective in the design of the drive system is to reduce as much as possible the working temperatures: higher efficiency in the drive system also means less heat in the mechanical components and, consequently, less required lubrication and minor friction coefficients. The R&D team has tested several low-friction solutions, offered by some of the main bearings manufacturers, in different operating conditions and has selected the most reliable and efficient solution for Marzoli FT60 and FT70 roving frames.

OUTSTANDING ENERGETIC PERFORMANCES

Marzoli aims at reducing the environmental impact of its processes and products during all phases of the product life cycle, starting from production to machinery use within the client's plant. Marzoli FT60 and FT70 roving frames fully embrace this business philosophy and deliver outstanding energetic performances throughout their service life.

The FT60 and FT70, thanks to their innovative technology, do not need suction. This, along with the high efficiency motors and an overall design intended to minimize friction, entails an energy saving of over 4 kWh with a reduction of the kW/kg ratio of over 10%.

REDUCTION IN POWER CONSUMPTION IN THE LAST 20 YEARS NEO.80

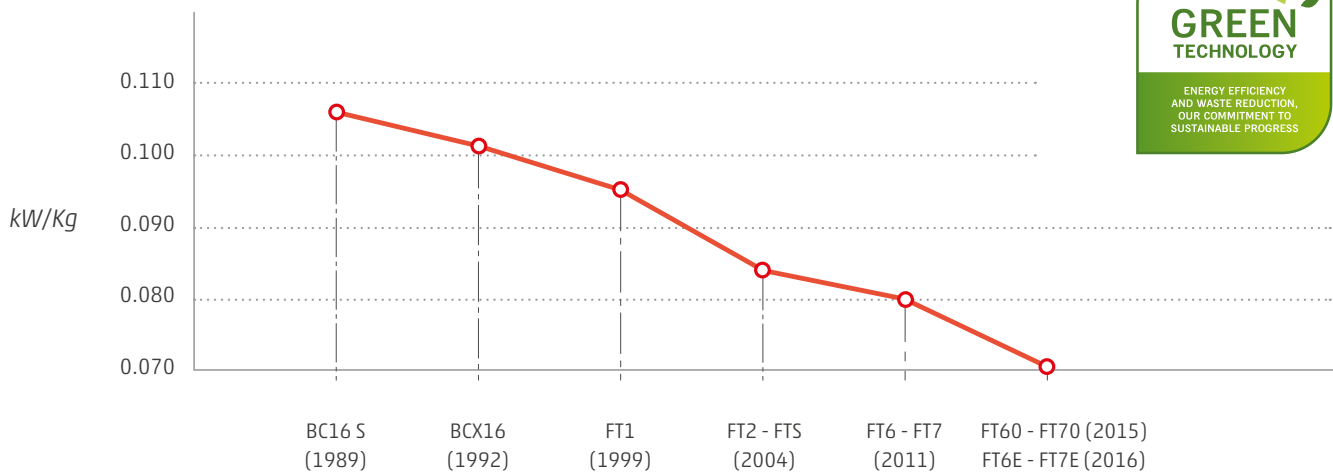

FT60 - FT70 power consumption					
Roving count Ne		0.5	0.8	1.2	1.5
Speed Rpm		1,050	1,200	1,220	1,250
Production gr/sp/h		1,900	1,210	640	460
kW/kg		0.035	0.070	0.128	0.187

The kW/kg values may vary according to the operational conditions of the machines.

TECHNICAL DATA

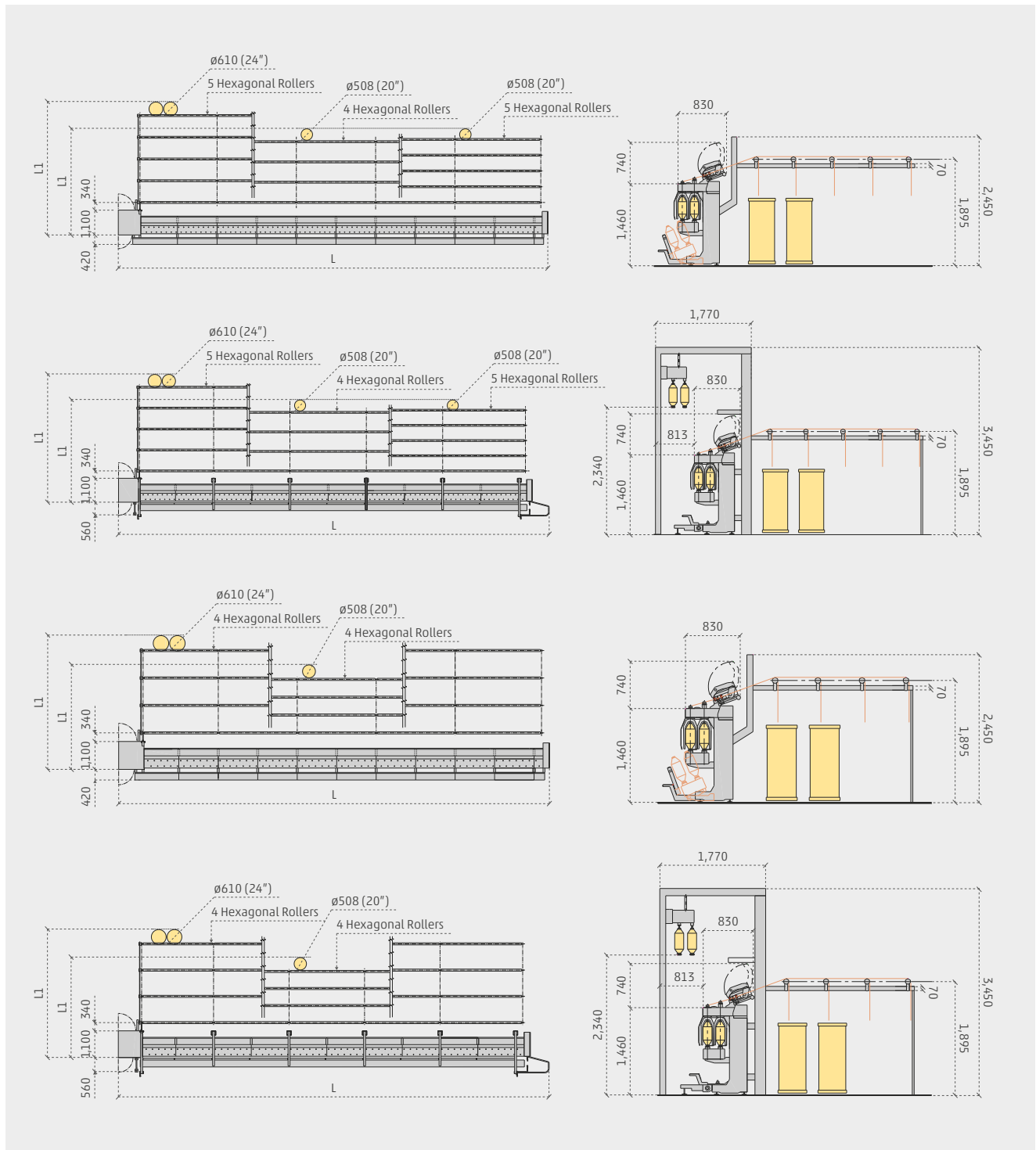

Roving Frame FT60 / FT70		FT60	FT60D	FT70	FT70D
Material	Cotton, man-made fibers and blends, up to 60 mm	110 mm	110 mm	130 mm	130 mm
Gauge		16	16	12	12
Spindles per section		240	240	192	192
Max. spindles		6"	6"	7"	7"
Bobbin size		no	yes	no	yes
Doffer		4 - 20			

Roving Frame FT60 / FT70	
Flyer speed	(mechanical) up to 1,500 rpm
Delivery speed	up to 50 m/min

FT60/FT60D				
	SEMIAUTOMATIC DOFFING		AUTOMATIC DOFFING	
	Mechanical draft	Electronic draft	Mechanical draft	Electronic draft
Cylinders drive motor	4 kW	5.5 Kw	4 Kw	5.5 Kw
Bobbin rail drive motor	3.77 kW	3.77 Kw	3.77 Kw	3.77 Kw
Bobbin rail outward motion drive motor	//	//	0.37 Kw	0.37 Kw
Doffing board drive motor	//	//	1.5 Kw	1.5 Kw
Belt drive motor	//	//	0.25 Kw	0.25 Kw
Spindles	3 Kw every 32			
Flyers	1.8 Kw every 32			
With suction drive motor (OPTIONAL)	+ 4 Kw			

FT70/FT70D				
	SEMIAUTOMATIC DOFFING		AUTOMATIC DOFFING	
	Mechanical draft	Electronic draft	Mechanical draft	Electronic draft
Cylinders drive motor	4 kW	5.5 Kw	4 Kw	5.5 Kw
Bobbin rail drive motor	3.77 kW	3.77 Kw	3.77 Kw	3.77 Kw
Bobbin rail outward motion drive motor	//	//	0.37 Kw	0.37 Kw
Doffing board drive motor	//	//	1.5 Kw	1.5 Kw
Belt drive motor	//	//	0.25 Kw	0.25 Kw
Spindles	3 Kw every 24			
Flyers	1.8 Kw every 24			
With suction drive motor (OPTIONAL)	+ 4 Kw			

FT60 Total length = 1085+ No.spindles*110mm+TS		FT70 Total length = 1085+ No.spindles*130mm+TS	
	TS		TS
Semiautomatic doffing without suction	395	Semiautomatic doffing without suction	345
Semiautomatic doffing with suction	625	Semiautomatic doffing with suction	575
Automatic doffing	1,170	Automatic doffing	1,120

Can Diameter (inches)	No. Rollers	Rows of cans	L1 (mm)	Can Diameter (inches)	No. Rollers	Rows of cans	L1 (mm)
20"	4	5	4,670	20"	4	4	4,150
	5				5		
	6				6		
24"	4	6	5,820	24"	4	5	5,310
	5				5		
	6				6		

SOFTWARE PLATFORMS

END2END PRODUCTION MANAGEMENT PLATFORM: YARNET

YarNet is Marzoli production management software. It enables the monitoring of production levels, efficiency rates and downtime for both individual machines and the entire spinning mill. Comparisons between machines on selected periods of time are made very simple so that improvement opportunities can be easily identified. YarNet enables the operator to edit production recipes, downloading and uploading them between any machine and their computer. He can also export them in Excel format to share with colleagues as necessary. YarNet gathers and analyses data about production and energy consumption, giving a visual representation of the tradeoffs (kW/kg).

MRM

MRM is Marzoli software to continuously monitor the operating conditions of textile machines. It can identify developing malfunctions before a fault occurs and highlight improvement opportunities on efficiency rates and energy consumption levels. Data about temperature, power consumption, speed and vibration are collected from PLCs (programmable logic controllers) and sensors installed on each machine. The software verifies the monitored parameters are within the nominal operating ranges; it can even adjust for room temperature variations to ensure continuous optimisation. If any parameter is out of tolerance, an automatic email alert is sent to the customer. The customer can also access the dedicated online portal to see information for predictive maintenance and of the overall efficiency of the plant. Through dedicated modules (Optimisation Tools) it is possible to optimise the performance of every machine, in particular on energy consumption and levels of efficiency. If required, Marzoli's customer service team can access the data to diagnose actual and developing problems and recommend appropriate actions.

KEY POINTS

- EASY & FAST CONTROL OF EVERY STAGE OF THE SPINNING PROCESS
- IMPROVED SPEED OF RESPONSE IN PRODUCTION OPERATIONS
- EASY MANAGEMENT OF PRODUCTION RECIPES
- SUPERIOR, EASIER AND FASTER MAINTENANCE

YARNET

Marzoli Production Management

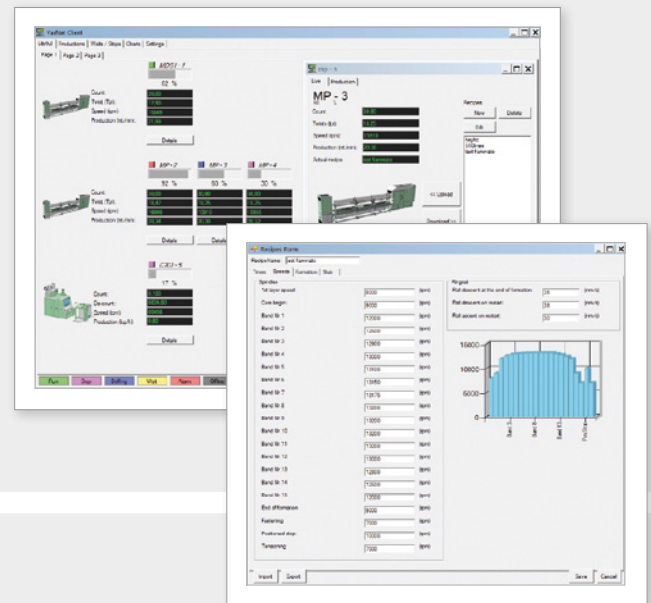

MRM

Marzoli Remote Maintenance

IoT Platform by Microsoft®

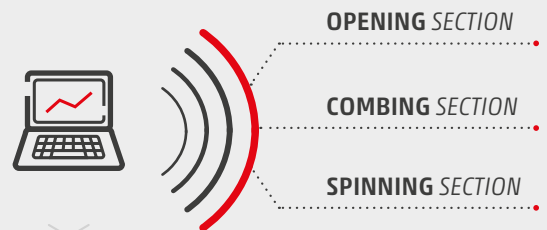

BENEFITS

- Higher productivity
- No machines unplanned downtimes
- Prevention from major machine failures
- Longer plant lifespan
- Higher efficiency
- Complete reliability
- Trouble free spinning experience
- Better maintenance planning



MARZOLI
INTERNATIONAL, INC.
USA

MARZOLI MACHINES
TEXTILE SRL
Italy

MARZOLI INDIA
MTMM PVT. LTD.
India

- Legend**
- Marzoli premises
 - Sales & service network
 - Sales affiliates

Marzoli Machines Textile S.r.l.
Via Sant'Alberto, 10
25036 Palazzolo sull'Oglio (BS)
Italy
Tel. +39 030 73091
sales@marzoli.it

Marzoli International, Inc.
100 Corporate Dr., Suite M
Spartanburg, SC 29303
U.S.A.
Tel. +1 864 599 7100
Fax +1 864 599 7111
sales@marzoli.com

**Marzoli India
MTMM Pvt. Ltd.**
Shed No 6, Bangalore Main Road
SIDCO Industrial Estate
Hosur - 635 126
Krishnagiri District, Tamil Nadu
India
Tel +91 4344 400111

MARZOLI
Textile Engineering

A Camozzi Group Company
www.marzoli.com