

OVERVIEW



**MARZOLI NONWOVENS**  
**CUSTOMIZED**  
**NONWOVEN LINES**



## HIGH QUALITY WEBS

Highest standards for opening  
cleaning & carding



In some segments of the nonwoven sector the preparation of a high quality web has become of the utmost importance. The market requires that products at direct contact with the consumer's skin show high standards of softness, tenacity, resistance to pilling. On the other hand these products must also be economic and therefore use the minimum amount of fiber. These market requests have fostered nonwoven producers to increasingly use fibers of finer deniers and natural fibers such as cotton.

Although the products that can be obtained showcase extraordinary properties, the use of these fibers entail challenges on the nonwoven producers that process them. First of all, these fibers need to be finely opened to guarantee a fine carding and consequently the production of an even web, a feature that becomes

more important the lighter the web is. Neps, dust and any other impurity (e.g. trash for natural fibers) needs to be removed.

The machines that reach the highest standards for opening, cleaning and carding of the fiber are the ones used in the short-staple fiber spinning process. Truth being told, the adoption of this machinery is not new to the nonwoven industry. Probably the adoption of machinery employed in spinning preparation in the nonwoven industry is just as old as the industry itself. But it is the great growth in flat cards productivity and the outstanding growth in complimentary technologies such as high-performance cross lappers that make this technology ideal for some nonwoven producers willing to differentiate along the lines of quality and flexibility.

# MARZOLI - ONE PARTNER & THE COMPETENCE OF MANY

## KEY POINTS

- ONE PARTNER FOR UNMATCHED QUALITY & FLEXIBILITY
- COMPETENCE OF MARZOLI & PARTNERS



Marzoli, one of the European leaders of spinning technology for short-staple fibers, through its competence in fiber preparation, strategic partnerships with some of the best European producers of downstream machines and through the experience acquired with some pioneering installations, is today capable of offering customized nonwoven lines.

Relying on Marzoli means:

- To rely on just one partner for the supply of a line of unmatched quality and flexibility
- To rely on the competence and technical skills of Marzoli and of its partners for the installation of the best technology and for its synchronization.



## FIBER PREPARATION

### Blow room & carding machines for higher quality and flexibility in nonwovens

#### KEY POINTS

- BLOW ROOM MACHINERY AND FLAT CARDS FOR HIGHER QUALITY ON CARDED AND AIR LAID WEBS
- MACHINES DESIGNED TO BOOST PRODUCTIVITY, QUALITY AND REDUCE WASTE



Industry experts argue that blow room and carding machinery used in the spinning preparation process entail substantial advantages for nonwoven producers working in the hygiene and medical sectors.

Blow room and carding machines allow to:

- Dedust the fiber through mote knives and cage condensers.
- Clean the fiber from impurities that may be contained, especially in natural fibers.
- Grant perfect blending of the raw material which ensures homogeneous properties of the end product.
- Progressively and finely open the raw material up to the fiber stage for a perfectly even card web.

The substantial increase in quality results has fostered nonwoven producers working in the hygiene and medical sector to adopt these machines even with air-laying technology.

The intensive opening action grants a better distribution of the fiber within the feed chute of the air laying machine and consequently a perfectly even web.

Blow room machines and flat cards have been installed also in combination with cross lappers on mechanical bonding and spunlace lines. The quality and flexibility that these lines have reached remains unmatched.

# MARZOLI BLOWROOM MACHINERY

Despite the great importance that blow room lines have on the quality of the end product and on the performance of the carding line, few manufacturers in both the nonwoven and the spinning industry have invested to innovate their machinery. Marzoli, on the other hand, has introduced substantial innovations to boost productivity and quality and reduce waste.

Marzoli B390L Duocleaner is equipped with two beaters and the fiber rotates eight times on the independently settable grids. The consequence is that Marzoli machine can reach a better percentage of trash removal before the coarse trash is broken into smaller pieces that are much harder to remove.

Marzoli B450L is a cage condenser with a working width of 1,250 mm. The integrated motor fan sucks the material from the previous machine and through the innovative feed duct makes the material hit the perforated cylinder at high speed. The perforated cylinder is sucked on both sides to reach a more homogeneous distribution of the fiber tufts on its surface. All these aspects grant a better dedusting action on the flocks. Marzoli B380L Duo-blended cleaner is an outstanding fine opener and cleaner.

The machine is equipped with an innovative feed device with accelerating rollers that drastically reduce the stress on the fiber that always occurs in traditional feed devices. The machine has two beaters with four carding segments and four mote knives that guarantee a progressive, fine opening and intensive cleaning (if required) of the fiber. Waste percentage can be adjusted through setting of mote knives and deflectors.

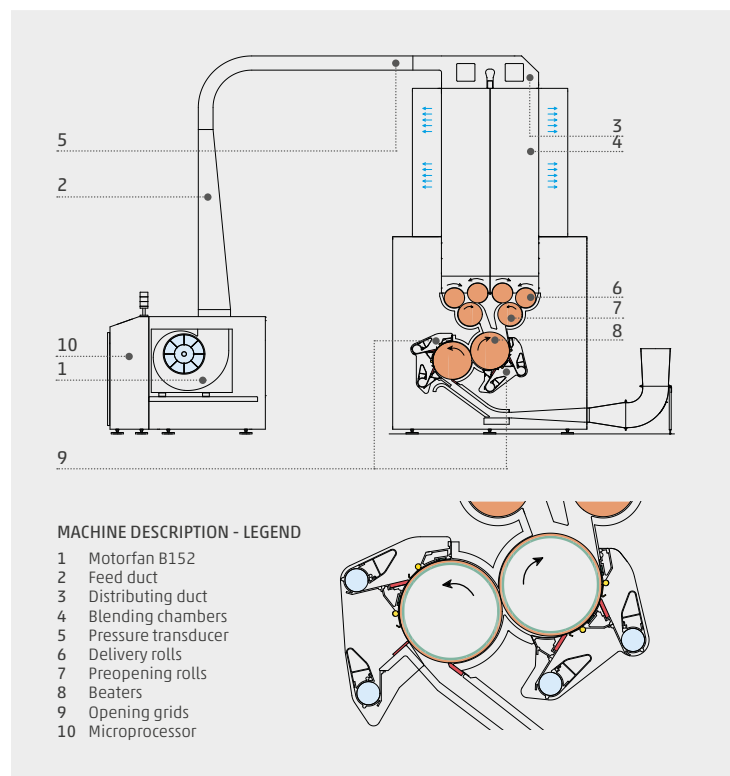
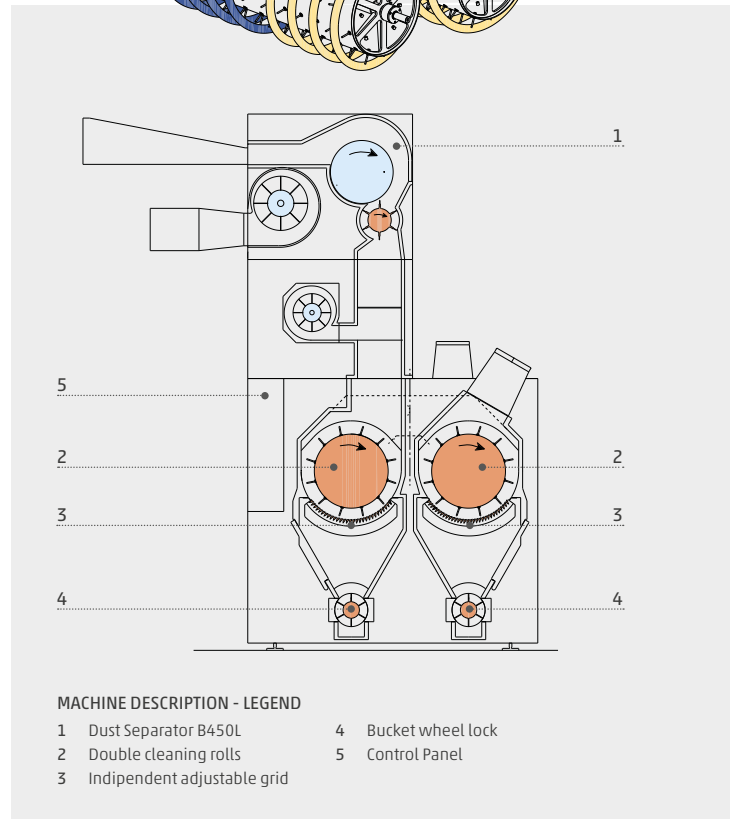
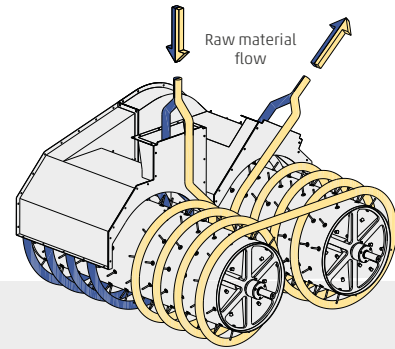

# WEB FORMATION

## KEY POINTS

- HIGH PRODUCTION CARD WITH WORKING WIDTH OF 1,500 mm
- STRATEGIC PARTNERSHIPS FOR TURNKEY PLANTS OF HYGIENE AND MEDICAL PRODUCTS

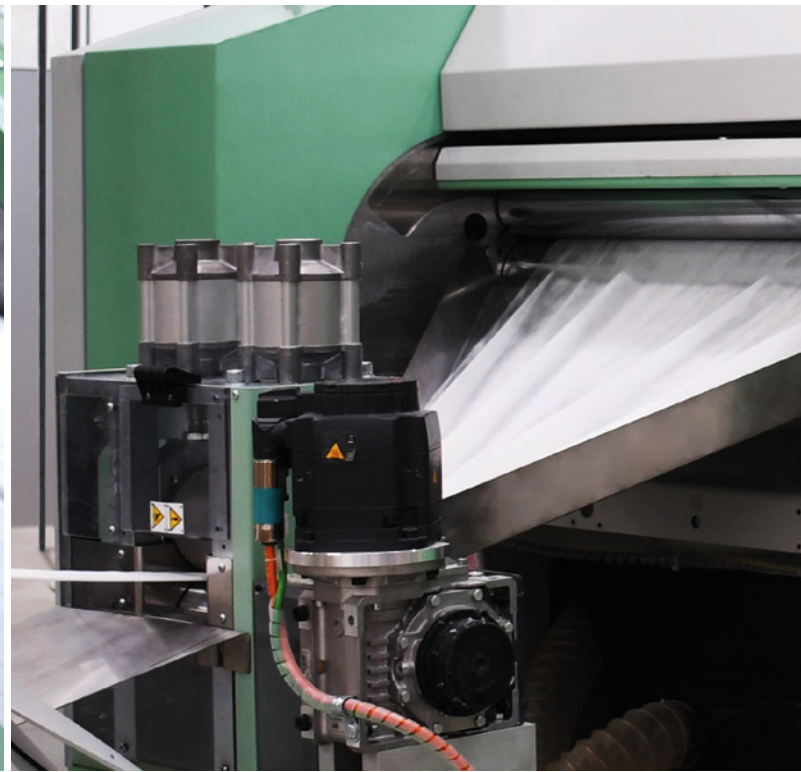

## MARZOLI C701

Marzoli C701 is a high production card with a working width of 1,500 mm. The large pre and post carding areas can be equipped with a high number of mote knives and stationary carding flats. 32 revolving flats in working position in the main carding area guarantee the best carding performance. Marzoli C701 for nonwovens can be equipped with a web delivery

module with purposely designed applications so that the desired product can be produced in an efficient and automated way. The card can be equipped with condensing and fiber randomization rollers to increase the weight of the web up to 60 g/sqm with an actual width of the card web of 1,450 mm.

## MARZOLI LINES

Marzoli has developed strategic partnerships with selected partners in order to offer a turnkey plant for the production and packaging of hygiene and medical products. Marzoli partners offer cross lappers, calenders, automated transport systems and other specific

machines for the production of:

- Standard and perforated zig-zag. These machines, directly connected with Marzoli cards, cut the cotton-wool band, earlier folded and prepared at the desired width.

- Absorbent cotton rolls.  
These machines, directly connected with Marzoli cards, produce rolls from 25 to 1,000 g with or without interleaving paper. They can also be equipped with a special external group to make cotton rolls of precut material so that single pads may be stripped. Embossing units are also available to emboss a drawing at customer's choice on the material.
- Cotton pads with standard or special shapes, e.g. rectangular or squared, to minimize production waste. Depending on the needs of the client, these machines can cut at the same time 3, 4 or 5 cotton pads.
- Cotton balls. These machines can be fed by cans or be directly connected to the card. Different levels of automation and productivity to cover all market requests



## ■ SPUNLACE LINES

Drawing on a full Marzoli line on spunlace projects entails several advantages:

- Unmatched quality, in terms of evenness and cleanliness from any kind of impurity with any kind of fiber.
- High isotropy: MD/CD close to 1:1 thanks to the implementation of state-of-the-art cross lappers.
- High productivity through a card web width of 1,450 mm, high performance cross lappers and drafters especially on light webs.
- Possibility to produce stratified webs.  
The arrangement of 3 or more cards and the possibility to feed them with separate feed lines allows to process different blends on each card. This allows to process one type of fiber for the external layers, the ones at contact with human skin, and another type of fiber for the inner layers.
- Perfect synchronization of the entire line and easy management through a monitor displaying all relevant production parameters.



MARZOLI  
INTERNATIONAL, INC.  
USA

MARZOLI MACHINES  
TEXTILE SRL  
Italy

MARZOLI INDIA  
MTMM PVT. LTD.  
India

- Legend**
- Marzoli premises
  - Sales & service network
  - Sales affiliates

**Marzoli Machines Textile S.r.l.**  
Via Sant'Alberto, 10  
25036 Palazzolo sull'Oglio (BS)  
Italy  
Tel. +39 030 73091  
sales@marzoli.it

**Marzoli International, Inc.**  
100 Corporate Dr., Suite M  
Spartanburg, SC 29303  
U.S.A.  
Tel. +1 864 599 7100  
Fax +1 864 599 7111  
sales@marzoli.com

**Marzoli India  
MTMM Pvt. Ltd.**  
Shed No 6, Bangalore Main Road  
SIDCO Industrial Estate  
Hosur - 635 126  
Krishnagiri District, Tamil Nadu  
India  
Tel +91 4344 400111

  
**MARZOLI**

Textile Engineering

A Camozzi Group Company  
[www.marzoli.com](http://www.marzoli.com)

