

OVERVIEW



Textile Engineering

GALILEO - BLOWROOM OPENING SECTION



Marzoli

Complete spinning line,
components and digitalized
solutions for the best performance
of the spinning process



THE ONE SOURCE FOR A FULLY-AUTOMATED AND DIGITALIZED SPINNING MILL

Marzoli, one of the major brands of the textile sector worldwide, is a unique European manufacturer of the complete line of machines for the opening, preparation and spinning of short-staple fiber. From the bale opener to the ring spinning frame, Marzoli offers the most advanced technology for a completely-automated spinning mill. Through its global sales and service network, its expertise on each type of fiber and application and the competence on the entire process, Marzoli represents a competent and reliable partner. And through its experience, know-how and commitment, it provides its customers with:

- Advanced spinning solutions through a careful activity of textile engineering. Marzoli assists its customers from the study of the spinning plan, throughout sourcing, erection and commissioning, up to maintenance of the resulting turnkey spinning plant, which can comprise Marzoli but also third-party machinery. The customer can rely on the competence and capability of a unique partner, responsible for the quality and productivity of the entire spinning mill.
- The advantages of smart spinning. No matter what the brand(s) of the machinery is, Marzoli can install its software platforms, YarNet and MRM, its hardware applications for gathering data on waste percentages and its composition, quality values, productivity indexes and other kpi data to let the customer build on the potential of Industry 4.0, optimize the entire spinning process through well-informed decisions and reach the highest performance in production operations.

OVER
160 YEARS
OF SUCCESSES

OVER
70 COUNTRIES
WITH ACTIVE CLIENTS



OPENING SECTION

- Openers & Cleaners
- Mixers & Blenders
- Card

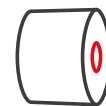

COMBING SECTION

- Draw Frames
- Lap Winder
- Comber
- Lap Transport



SPINNING SECTION

- Roving Frame
- Ring Spinning Frame
- Bobbin Transport System

BLOWROOM LINE

Fine & gentle opening of the feedstock at high production

KEY POINTS

- EFFECTIVE OPENING
- EXCELLENT CLEANING AND PERFECT BLENDING
- EFFICIENT DE-DUSTING
- HIGH PRODUCTIVITY (UP TO 1,600 Kg/h)
- LOW FIBER STRESS
- LOW AMOUNT OF GOOD FIBER IN THE WASTE



Although the productivity of Blowroom machinery has increased steadily in the last decades, few innovations have revolutionized the concepts of blending, opening and cleaning of the fiber.

The opening of the fiber is still obtained through a strong impact between the feeding cylinder and the beater, whose speeds ratio can be as high as 150/1. The higher production in the blow room line, as well as in the cards, has been achieved through higher speed of the beaters and more aggressive carding elements: grids have been replaced by carding sectors with knives for the waste and beaters with saw tooth wires are now commonly utilized.

However, this entails drawbacks: it dramatically increases the stress on the fibers, often reducing their elasticity and natural resistance, and creates greater amounts of short

fibers, because of their breakage. Therefore, in order to preserve yarn quality spinners are often forced to increase the amount of waste, with a negative impact on the final profit. Moreover, the installed power and the quantity of air needed for cleaning and transporting the fibers are higher, and not always in proportion to the increased production.

During the design of its opening line, Marzoli has introduced innovations to avoid the drawbacks listed above and consequently achieve the following objectives:

- higher productivity;
- reduction of waste with the same quality level;
- reduction of energy consumption;
- reduction of investment costs;
- reduction of managing costs.

These goals have been achieved thanks to:

1. New concept of fiber treatment. A special accelerating cylinder between the feeding cylinders and the first beater has eliminated the violent action on the fiber, replacing it with a more controlled and progressive one that allows to:
 - increase the production of the machines and of the line without affecting the natural features of the fiber;
 - reduce the stress on the fibers;
 - prevent fiber breakages;
 - enhance quality of the final yarn;
 - feed the opening beater with open flocks, favoring trash elimination.
2. Greater carding area & number of feeding chambers. Greater carding and de-dusting areas entail more efficient and effective cleaning. A higher number of feeding chambers grants:
 - better blending;
 - the reduction of material being processed by each cylinder, making opening more effective.

In conclusion, with Marzoli's innovations, spinners can increase production while keeping the same quality level and gain significant economic benefits especially in the cost of raw material, thanks to the reduced amount of good fibers being discarded. As cotton prices are likely to grow in the future, these economic benefits will become even greater. Moreover, the great uncertainty surrounding cotton price makes the reduction of the wastage of raw material one of the best risk management activities for spinners.

Marzoli blow room line outcomes

- Excellent opening, cleaning and blending performance.
- Gentle treatment of the fibers to enhance yarn quality (avoid damages, reduce the number of short fibers and neps) and reduce the amount of good fibers in the waste.
- High productivity: a single machine can reach production levels up to 1,600 kg/h.
- Efficient de-dusting.

Marzoli Blow room line features

- Marzoli Blowroom line allows to process all short-staple fibers:
 - all types of cotton;
 - man-made and synthetic fibers;
 - technical fibers;
 - short wool;
 - gin notes.
- The modular design of the machines allows to reduce the cost of the complete line.
- All working parameters are set through electronic panels located on the machines.
- Easy cleaning and maintenance thanks to optimal accessibility of working organs.
- All machines are equipped with Marzoli Green Technology.



MARZOLI
GREEN
TECHNOLOGY

ENERGY EFFICIENCY
AND WASTE REDUCTION.
OUR COMMITMENT TO
SUSTAINABLE PROGRESS

SUPERBLENDER B12

Fine raw material plucking

KEY POINTS

- 2 BEATERS AND 2 CONVEYING ROLLERS FOR FINE OPENING OF THE RAW MATERIAL
- MINIMUM STRESS OR CURLING OF FIBERS
- PRODUCTION UP TO 1,600 kg/h
- SETTABLE FOR TWO ASSORTMENTS



Superblender B12 outcomes:

- Very small flocks thanks to 2 beaters, each with 254 tips, and to 2 moveable conveying rollers that control the material during plucking;
- smooth and continuous material plucking all the way down to the floor thanks to the free and upright movement of the detacher and to the moveable conveying rollers;
- high reliability and safety;
- production capacity with one assortment and working width of the detacher of 2,250 mm of 1,600 kg/h (depending on the processed fiber);
- suction from downstream cage condenser to avoid the formation helicoidal air flows within the transportation tubes and consequently neps formation.

TECHNICAL DESCRIPTION - LEGEND

- Photocell
- Photocell activated, detacher stops and moves upwards

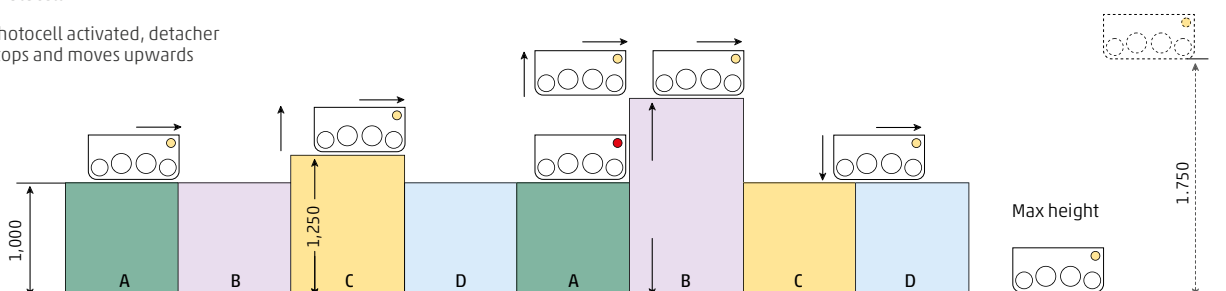

Automatic production adjustment

Vertically-movable grid with linear transducers to control tips penetration inside the bales and therefore adjust the amount of throughput (kg/h) according to:

- the height of the bales, so that all bales are leveled at the same height;
- the amount of material inside the mixer: a pressure switch, located on the mixer, acts directly on the B12 grid to increase its production when the material inside the mixer goes down, and vice versa.

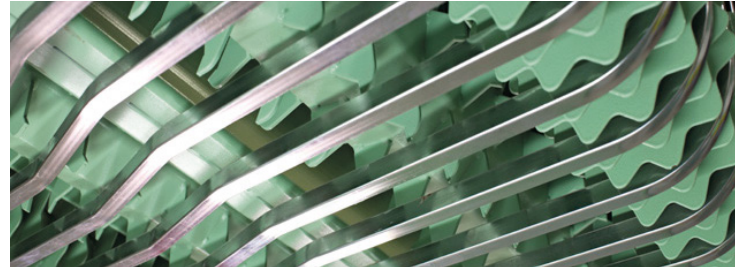

MACHINE DESCRIPTION - LEGEND

- | | |
|------------------------------------|---|
| 1 Control panel | 6 Two plucking rolls |
| 2 Bale lay-down area | 7 Two vertically-moving conveying rollers |
| 3 Detacher (1,700 mm or 2,250 mm) | 8 Conveying winding roller |
| 4 Automatic rotating tower | |
| 5 Duct for material transportation | |

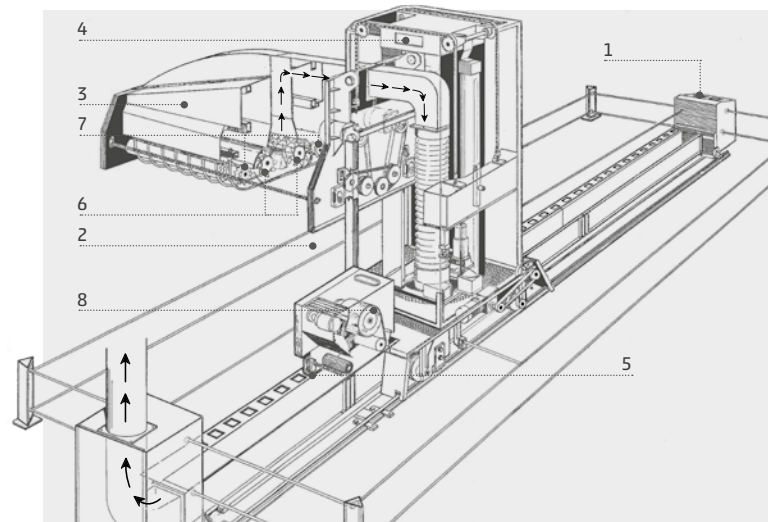

TECHNICAL DATA

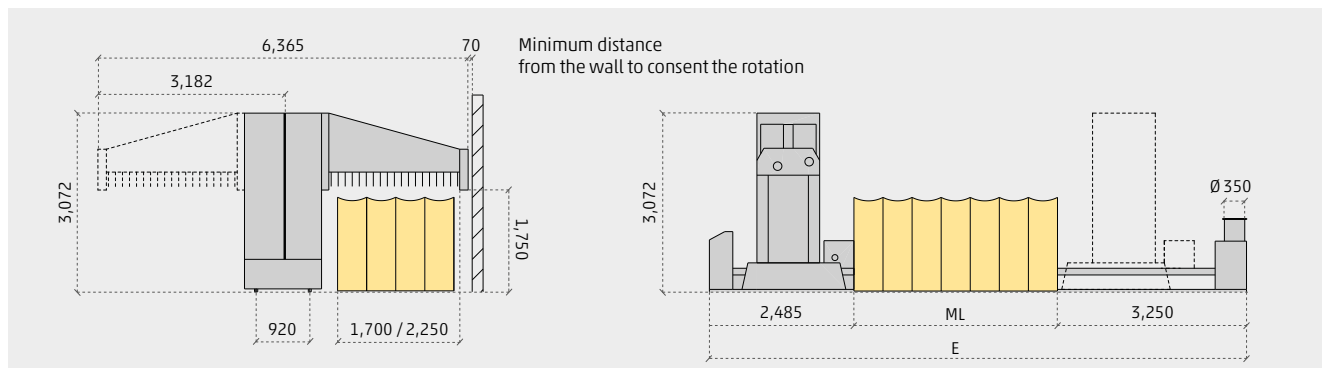

B12	
Processed raw material	Cotton, man-made fibers up to 65 mm (2 1/2")
One assortment	B12 - 1,700 mm up to 1,100 kg/h B12 - 2,250 mm up to 1,600 kg/h Production depending on the processed fibers
Two assortments	B12 - 1,700 mm up to 800 kg/h B12 - 2,250 mm up to 1,100 kg/h Production depending on the processed fibers
Installed power	B12 - 1,700 mm 7.92 total kW B12 - 2,250 mm 9.92 total kW
Space available for bales	ML= E - 5,735 mm
No. of bales each side for one assortment (according to bales dimensions):	· wide carriage (ML/B) x 1.5 or (ML/L) x 3 · small carriage (ML/B) or (ML/L) x 2 ML= space available for bales B= bale width L= bale length
Duct length	E 11.13 - 46.13 m in steps of 2.5 m
Net weight	B12 - 1,700 mm 3,500 kg B12 - 2,250 mm 3,700 kg Approx. 90 kg/m (for variable longitudinal parts)
Power Consumption to process 100 kg of raw material	0.68 kW

DUOCLEANER B390L

Excellent cleaning at twice the production rate

The B390L Duocleaner is a very efficient cleaner that can reach 1,600 kg/h while granting outstanding quality standards thanks to its innovative working concept. The material enters at the center of the first beater and it is split into two flows that are processed separately by the two halves of the two beaters. Each flow of material, thanks to special deviators, rotates four times around the first semi-beater and another four times around the second semi-beater. The two flows of material then rejoin at the center of the second beater. The B390L Duocleaner allows to achieve outstanding cleaning and productivity outcomes because:

- The material is split into two flows which entails that each section of the two beaters process a relatively small amount of material in the time unit.
- The material makes eight turns around the beaters which is the highest number among competitor openers.
- The first and the second beater have different point densities, different speeds and different settings of the grids. This entails a progressive opening action for a more gentle treatment of the fibers and a thorough cleaning activity.

Machine features

- Production up to 1,600 Kg/h depending on the processed fiber;
- beaters with different rotating speeds and tips numbers (faster and more populated the second one);
- independent speed setting of the beaters;
- grids with a different number of segments with a total area of 2.24 m²;
- independent setting of the four grids;
- total dedusting area of 1.6 m²;
- two different waste chambers;
- working width of 1,600 mm for each beater

KEY POINTS

- PROGRESSIVE OPENING AND EXCELLENT CLEANING
- GREAT PRODUCTIVITY (1,600 Kg/h)
- LOW FIBER STRESS
- NO NEPS FORMATION
- EFFICIENT DEDUSTING



Low fiber stress

Excellent cleaning is possible only after effective opening: the Superblender provides the mini tufts; the Duocleaner removes trash particles, fiber fragments and dust. Since the Duocleaner has no nipping point, low fiber stress and no neps formation are achieved.

Optimized cleaning

The waste accumulated after the four grids is transferred through the two bucket wheel locks to a continuous centralized suction system.

Efficient dedusting

Dust causes many problems in the spinning mill. The B450L, placed on the top of B390L, efficiently dedusts all the flocks coming from the bale plucker, thanks to its suction system.

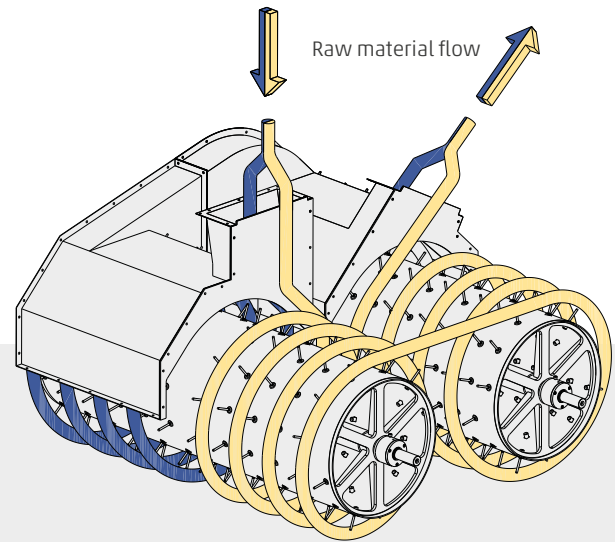
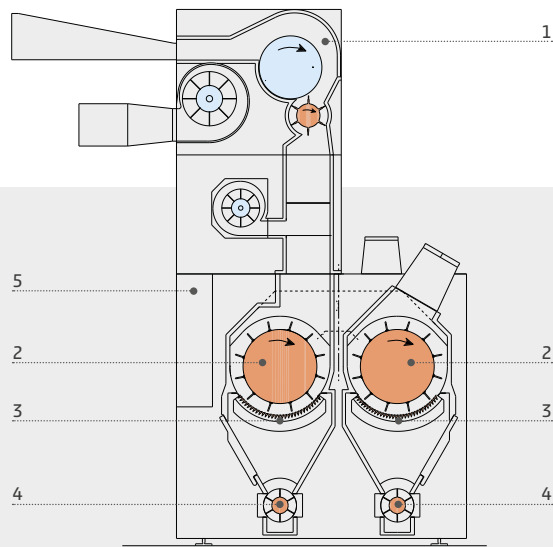

MACHINE DESCRIPTION - LEGEND

- 1 Dust Separator B450L
- 2 Double cleaning rolls
- 3 Independent adjustable grid
- 4 Bucket wheel lock
- 5 Control Panel

TECHNICAL DATA

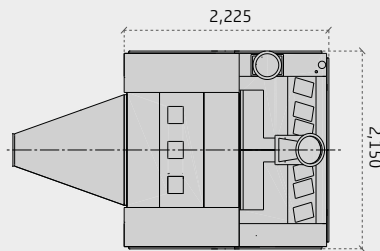
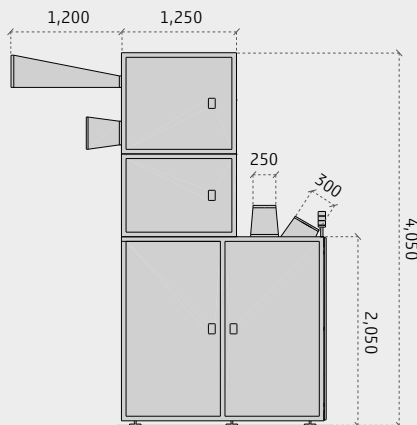

B390L

Processed raw material	Cotton, cotton waste, gin motes and blends up to 65 mm length Production up to 1,600 kg/h depending on the processed raw material
Installed power	12.25 kW
Working width	1,600 + 1,600 mm
Cleaning rolls	700 mm dia.
Speed range	Cleaning roll in 400 - 600 rpm Cleaning roll out 600 - 900 rpm
Net weight	B390L 3,400 kg B450L 1,000 kg

Power Consumption to process 100 kg of raw material 0.76 kW

AUTOMIXER B143L

Technology for effective blending and dedusting at high production levels

KEY POINTS

- TOP BLENDING PERFORMANCES AND ABSOLUTE RELIABILITY
- HIGH PRODUCTIVITY (1,600 Kg/h)
- NO NEPS FORMATION
- EXCELLENT DE-DUSTING
- LOW ENERGY CONSUMPTION



An effective blending of cottons, ensures greater uniformity and stability of the blend, thus improving its performance and its commercial assessment.

The B143L with 4 or 8 blending chambers and working width of 1,600 mm, has been designed in order to achieve the following objectives:

- Top blending performances;
- production up to 1,600 kg/h;
- absolute reliability;
- low maintenance;
- dedusting area of 10 m² (for the 8 chambers model).

Reliable performance

A smooth air stream delivers the fiber tufts to the blending chambers where the material is pneumatically compacted. A pair of grooved delivery rolls and an opening roll for each blending chamber open the raw material which is then mixed in the blending channel and sucked by the air stream of the cage condenser or the fan of the opener placed after the Automixer.

Soft treatment of the fibers

The innovative design of the transport fan allows to keep neps formation in the raw material to a minimum.

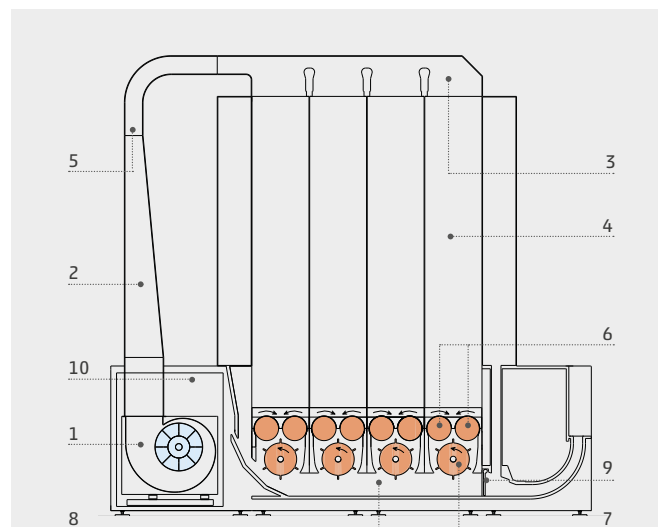

MACHINE DESCRIPTION - LEGEND

- | | |
|-----------------------|--------------------|
| 1 Motorfan B152 | 6 Delivery rolls |
| 2 Feed duct | 7 Opening rolls |
| 3 Distributing duct | 8 Blending channel |
| 4 Blending chambers | 9 Air by-pass |
| 5 Pressure transducer | 10 Microprocessor |

Design of the feeding hood

The particular design of the feeding hood allows a homogeneous distribution of the fibers among the cells of the mixer.

Large capacity

The design of the blending chambers of the B143L automixer allows production levels up to 1600 Kg/h, depending on the type of material.

De-dusting surface

The large de-dusting surface of Automixer B143L allows an excellent removal of the dust from the raw material even when working at high production volumes.



Low power consumption

Despite its high production capacity, the B143L automixer has outstandingly low installed-power and energy-consumption levels.

TECHNICAL DATA

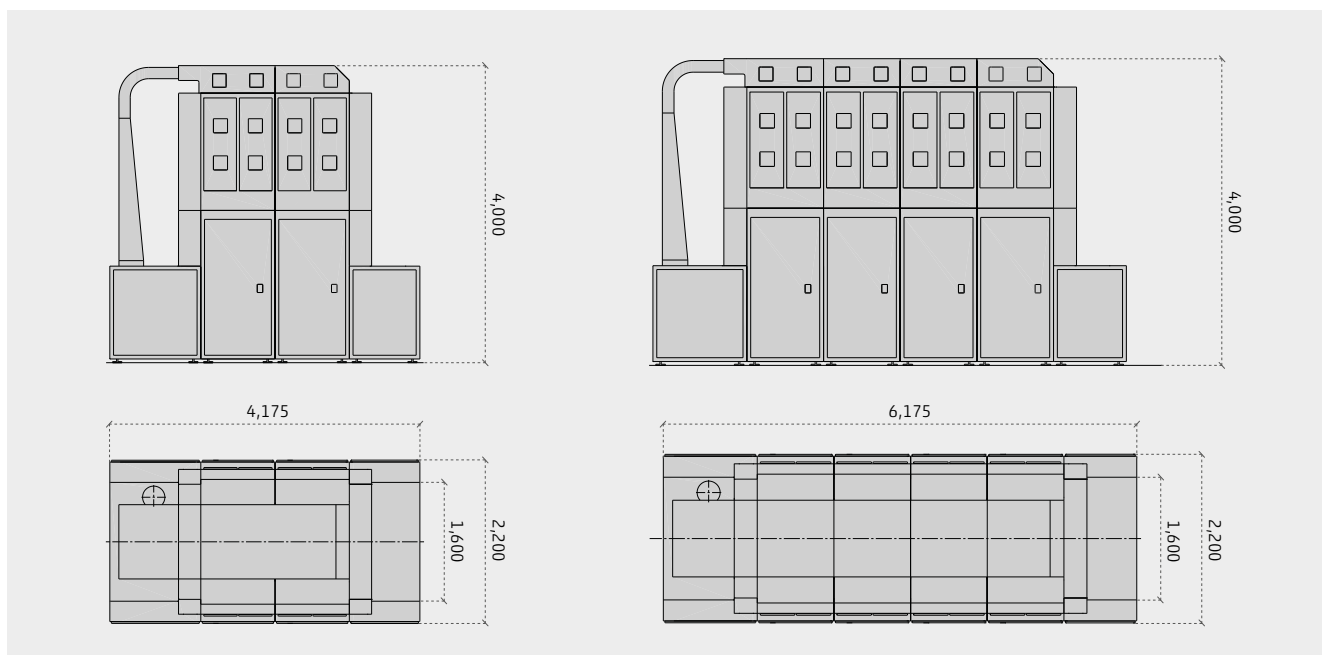

B143L

Processed material	Cotton, man-made fibres and blends up to 65 mm length Production up to 1,600 kg/h with 8 chambers depending on the processed raw material
Storing capacity	550 kg cotton fibers (8 chambers) 450 kg man made fibers (8 chambers)
Installed power including B152	11.2 kW (4 chambers) 11.4 kW (8 chambers)
Working width	1,600 mm
Net weight	4,000 kg (4 chambers) 5,200 kg (8 chambers)
Power Consumption to process 100 kg of raw material	0.71 kW

DUST SEPARATOR B450L

Effective and efficient dedusting

A smart and efficient solution to clean the raw material from dust, pepper trash and micro fibers is the innovative B450L. The tufts of raw material, coming from the B12, go through the B450L's conveyor and hit its perforated cylinder. The design of the conveyor and the large working width of the perforated cylinder ensure a strong impact of the tufts against the cylinder while the optimized air flow for fiber transportation ensures low power consumption. The perforated cylinder is sucked from both sides through an integrated motor fan. This ensures that the tufts are better distributed on the cylinder and better cleaned. The cylinder rotates and delivers the dedusted tufts to a detaching roller which collects them and makes them fall into the duct. The B450 constitutes a smart solution also because it does not curl or damage the fibers in any way.

KEY POINTS

- HIGH DEDUSTING SURFACE
- NO NEPS CREATION
- PRODUCTION ABOVE 1,600 kg/h

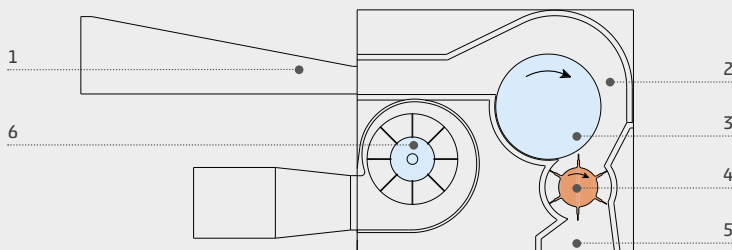

MACHINE DESCRIPTION - LEGEND

- 1 Conveyor
- 2 Feeding box
- 3 Perforated cylinder
- 4 Detaching roller
- 5 Material delivery
- 6 Motor fan

TECHNICAL DATA

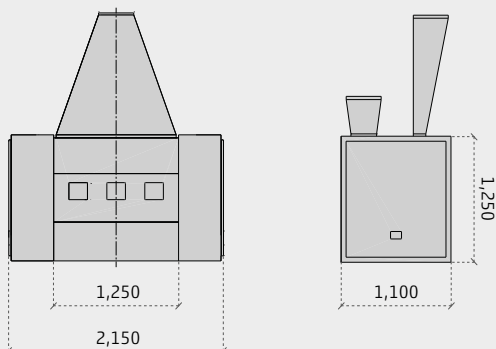

B450L

Processed material Cotton, man-made fibers and blends
up to 65 mm - Production up to 1,600 kg/h
depending on the processed raw material

Installed power 0.75 kW machine main motor
Two options for the motorfan:
7.5 kW - 11 kW

Working width 1,250 mm

Air capacity from 3,500 to 7,500 m³/h

Power Consumption to process 100 kg of raw material, included motorfan
from 0.39 up to 0.73 kW

DUO BLENDED CLEANER B380L

Technology for a gentle but intensive opening and cleaning action

Gentle but intensive opening

The B380L duo blended cleaner allows to open and clean the raw material in a gentle but intensive way while working at high production levels. This is possible thanks to the progressive opening and carding action, which reduces the stress on the fibers without affecting the opening and cleaning outcome.

Fibers in the B380L are freely delivered to the first beater without being held by the nipping mechanism that traditionally occurs between the feeding roller and the feeding table.

The special pre-opening rolls reduce the fiber stress caused by the speed difference between the feeding roller and the beater.

The two beaters, with different pins densities, rotate at different speeds in order to further open the material but always with low stress on the fibers.

KEY POINTS

- GENTLE BUT INTENSIVE OPENING
- EXCELLENT CLEANING, WASTE REDUCTION AND HIGH FLEXIBILITY
- EFFICIENT DEDUSTING AND EFFECTIVE BLENDING
- EASY MAINTENANCE & CLEANING
- PRODUCTION UP TO 1,000 Kg/h



EXCELLENT CLEANING

The independent speed of the two beaters, controlled by inverter, can be set by keyboard, according to the processed raw material. The quality and quantity of the waste can be easily modified with a simple setting of the deflector blades.

WASTE REDUCTION

The progressive opening and carding action improves the selection of the fibers, thereby reducing the amount of waste with the same cleaning efficiency of the raw material.

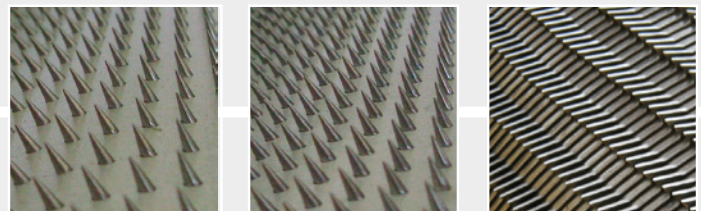

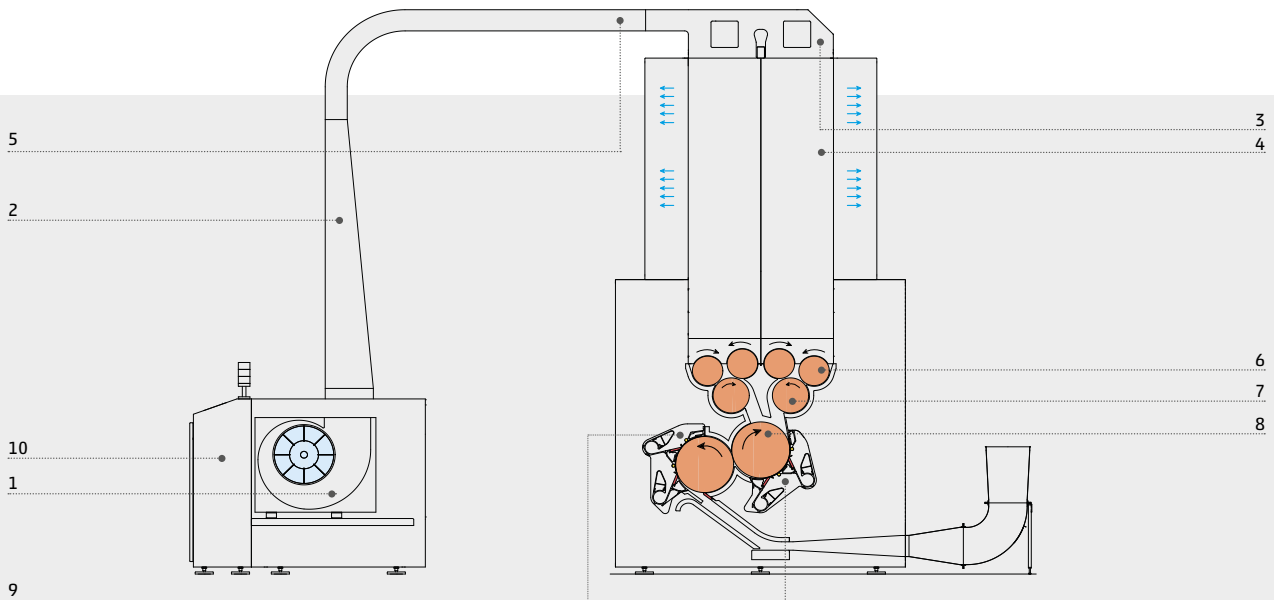

MACHINE DESCRIPTION - LEGEND

- 1 Motorfan B152
- 2 Feed duct
- 3 Distributing duct
- 4 Blending chambers
- 5 Pressure transducer
- 6 Delivery rolls
- 7 Preopening rolls
- 8 Beaters
- 9 Opening grids
- 10 Microprocessor

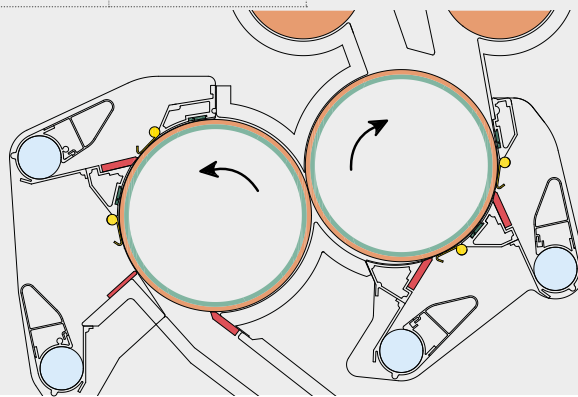

- KNIVES
- DEFLECTORS
- SEGMENTS

High flexibility

The customer can choose between several types of beaters (pinned, needle and sawtooth) according to the fiber to process.

Moreover, the hoods with knives, the flaps and the suction pipes of the B380L duo blended cleaner can be opened in order to guarantee the highest level of accessibility of the machine and to allow a fast replacement of the beaters. This allows the customer to process several types of materials with the same machine always with the highest performances. Moreover, in blow room lines with several opening and cleaning points, it is possible to use only B380L with different configurations, instead of various types of machines. This reduces the number of necessary spare parts, with a great economic advantage for the customer.

Efficient dedusting

The B380L, thanks to its two blending chambers with a surface of 3 sqm, dedusts the processed material

before it enters into the machine. The trash particles and dust, removed during the opening action, are conveyed by the suction hoods to the client's centralized suction system. Permanent suction considerably improves dedusting of cotton.

Effective blending

The B380L, through its two separated blending chambers, mixes the raw material. In blow room lines with one or more fine openers, the blending action of the B380L adds up to the blending capacity of the mixer and allows to obtain perfect blends.

Easy cleaning & maintenance

The B380L geometry guarantees the maximum accessibility to all the working organs. This makes cleaning and maintenance easy and effective, allowing the machine to always work at its best.



TECHNICAL DATA

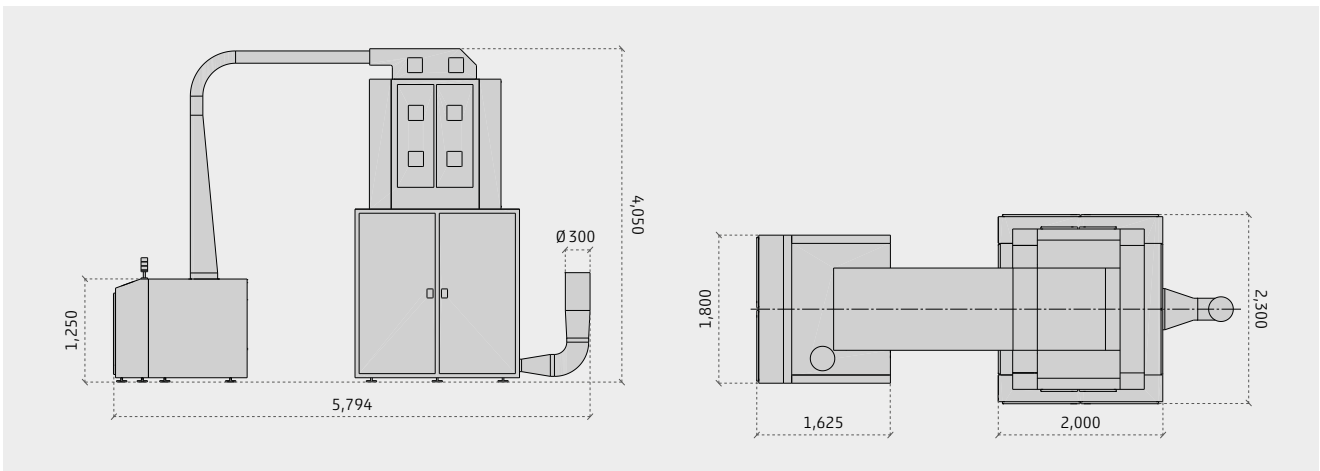

B380L

Processed material	Cotton, man-made fibers and blends up to 1,000 kg/h depending on the processed material
Installed power	16.62 kW
Frame width	1,600 mm
Opening roll	400 mm dia.
Speed range	600 - 1,100 rpm
Net weight	4,340 kg
Power Consumption to process 100 kg of raw material	1.62 kW

B13 AND B23 TUFT BLENDING INSTALLATION

The quality of blending is far better than other systems

An effective solution for tuft blending is the combination of two or more B13 weighing bale openers and one B23 tuft blender.

Thanks to the optimum weighing precision and self-calibration of the weighing pan this solution ensures perfect blends. The operator, through a display presets the target weights for each B13 in order to achieve the desired tuft blend. Once production has begun, each B13 works until it reaches its target weight and then it stops. Once all B13 stop, they discharge the processed material which falls on the conveyor belt of the B23, placed underneath. After all the B13 have discharged, the conveyor belt of the B23 moves and carries each layer of material under the next B13; then it stops and awaits the B13 to discharge again. Through this process the first B13 creates the first layer on the conveyor belt; the second B13 creates the second layer which lies on the first one and so on. Once the last layer is created, the conveyor belt of the B23 carries the two (or more) layers to the pressure table and the pincer roll. The layers are then opened through an opening roll and sent through a duct to the mixer.

KEY POINTS

- PERFECT TUFT BLENDING
- HIGH WEIGHING ACCURACY
- HIGH PRODUCTIONS
- SELF CALIBRATION OF THE BALANCES
- UP TO 5 COMPONENTS IN THE BLEND
- PERFECT SOLUTION FOR FLEXIBLE PRODUCTION PROGRAMS



High weighing accuracy

The B13 weighing bale opener fills up at high speed and then reduces the speed as it approaches the pre-set target weight. Thanks to this system, the B13 weighing bale opener achieves the maximum weighing accuracy, with an average weighing discrepancy of less than 1%.

The weighing accuracy is not affected by variations in density, volume or type of fiber being processed.

High production

Thanks to the large capacity of the weigh-pans, the B13 weighing bale opener allows to reduce the number of weighing operations. The abundant material reserve reduces machine downtimes. All this guarantees excellent productivity.

USER-FRIENDLY INTERFACE

Simple operations and monitoring

- The microcomputer controls and guides the operator with simple messages;
- the microcomputer identifies malfunctions and suggests remedies;
- working programs can be stored and repeated;
- the display shows target and actual weights, cv values, production rates of shifts;
- automatic actual weight correction.

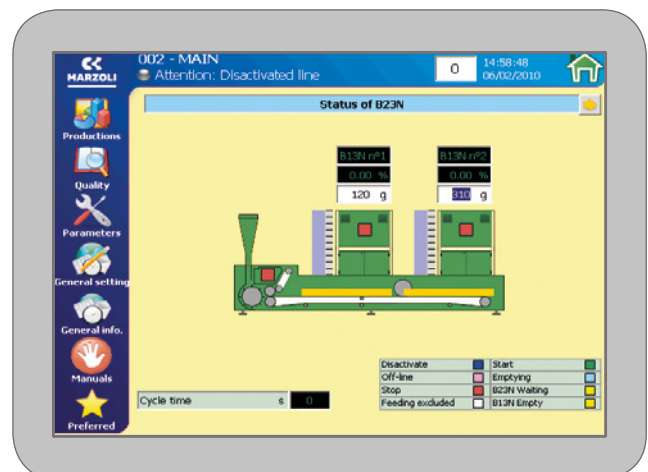

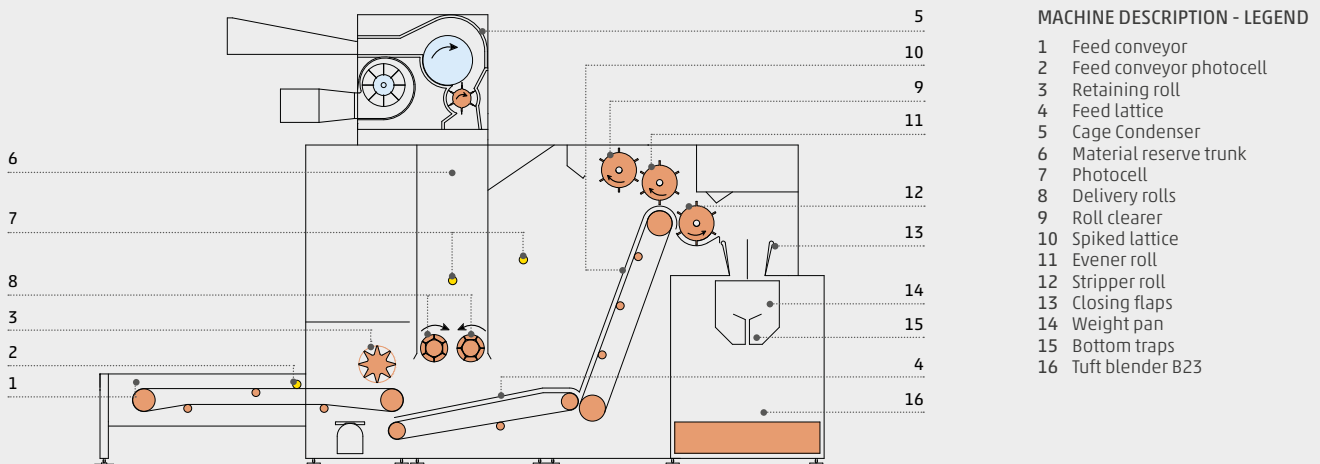

■ TUFT BLENDING INSTALLATION FOR ALL NATURAL AND MAN-MADE FIBERS

The B13 Weighing Bale Opener

- Automatic calculation of the production and of the weights;
- every 50 weighings (the number of weighings is settable) the CV calculation is automatically activated (CV%). The machine automatically adjusts the setting when the CV is beyond the preset tolerance value;
- automatic control of the turbulences produced by the fall of the material on the balance;
- possibility to operate continuously with open balance;
- possibility to choose up to 10 working programs;
- possibility to automatically set the machine production with the evener roll;
- automatic emptying of the B13 + B23 systems;
- frame width: 1,200 mm;
- the B13 Weighing Bale Opener can be fed manually and is therefore suitable for processing small lots. The length of the feed table can be adapted to the space available;
- the B13 Weighing Bale Opener can be fed also automatically (through the B450L Cage Condenser) and is therefore also suitable for processing large lots;
- consequently the B13 is the ideal solution for highly flexible installations which can be used to process large lots as well as occasional small lots;
- indirect discharge of the tufts into the weigh pan avoids weighing mistakes.

■ TECHNICAL DATA

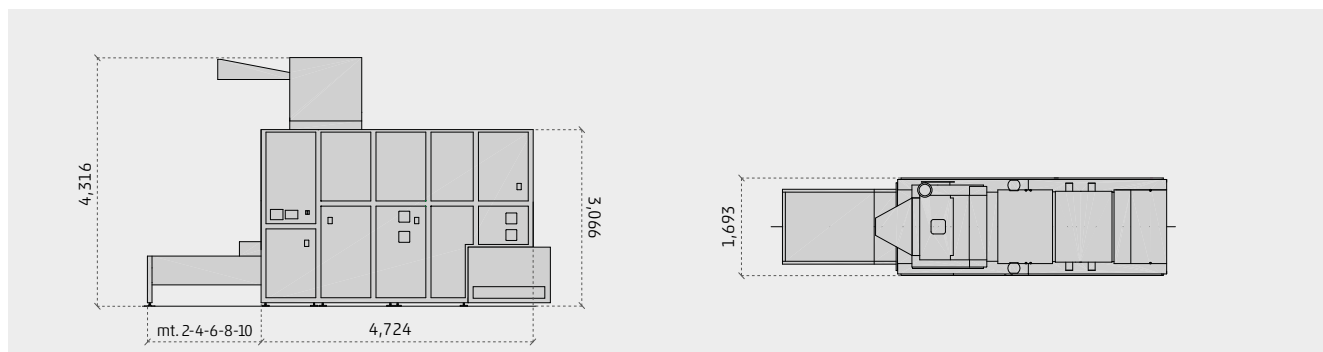

B13

Processed material	Cotton, man-made fibers and blends up to 350 kg/h Production depending on the processed fiber
Installed power	4.43 kW excluding B450
Weigh	4,100 kg excluding feeding lattice

Power Consumption to process 100 kg of raw material 1.26 kW

TUFT BLENDER B23

Up to 5 components can be weighed for precise blends



B23 Tuft blender with one delivery

- Maximum production up to 1,000 kg/h with a frame width of 1,000 mm;
- The B23 Tuft Blender can be fed by up to five B13 weighing bale openers. The weighing feeders discharge the material on the conveyor belt of the tuft blender; the different blend components are placed on top of each other in layers.

MACHINE DESCRIPTION - LEGEND

- | | |
|----------------------------|------------------|
| 1 B13 Weighing Bale Opener | 5 Pressure roll |
| 2 B23 Tuft Blender | 6 Pressure table |
| 3 Blending table | 7 Pincer roll |
| 4 Conveyor belt | 8 Opening roll |

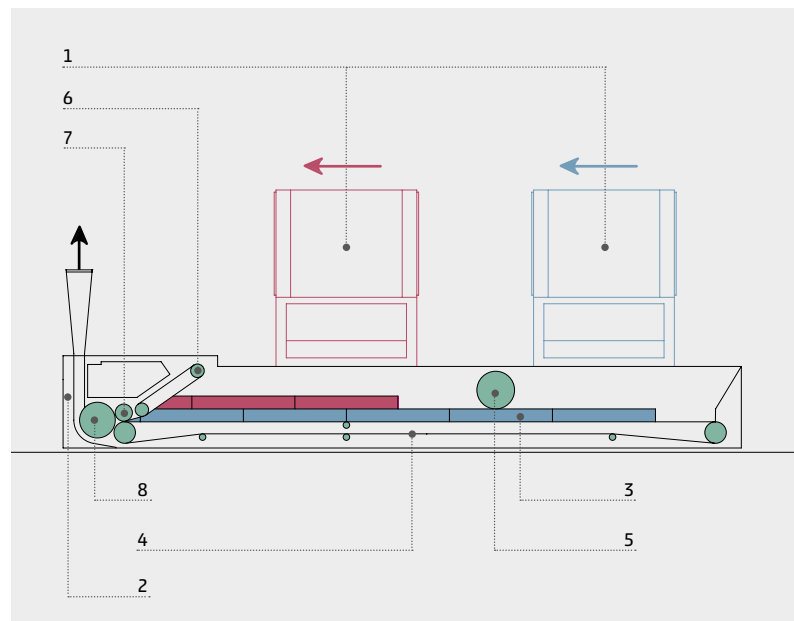

B23 TUFT BLENDER WITH TWO DELIVERIES

- The B23 with two deliveries with an additional B13 feeder (c) is the ideal solution for a better flexibility of the installation and for plants where blends frequently change.
- Line 1 can comprise three feeders (A, B and C) while line 2 includes the other two (D and E). Alternatively Line 1 can comprise two feeders (A and B) while line 2 includes the other three (C, D and E).
- In this case the minimum gauge (S) between the B13 feeders is 4,200 mm and the maximum gauge (S) is 5,400 mm;
- the 3,000 mm gauge (S) is not available.

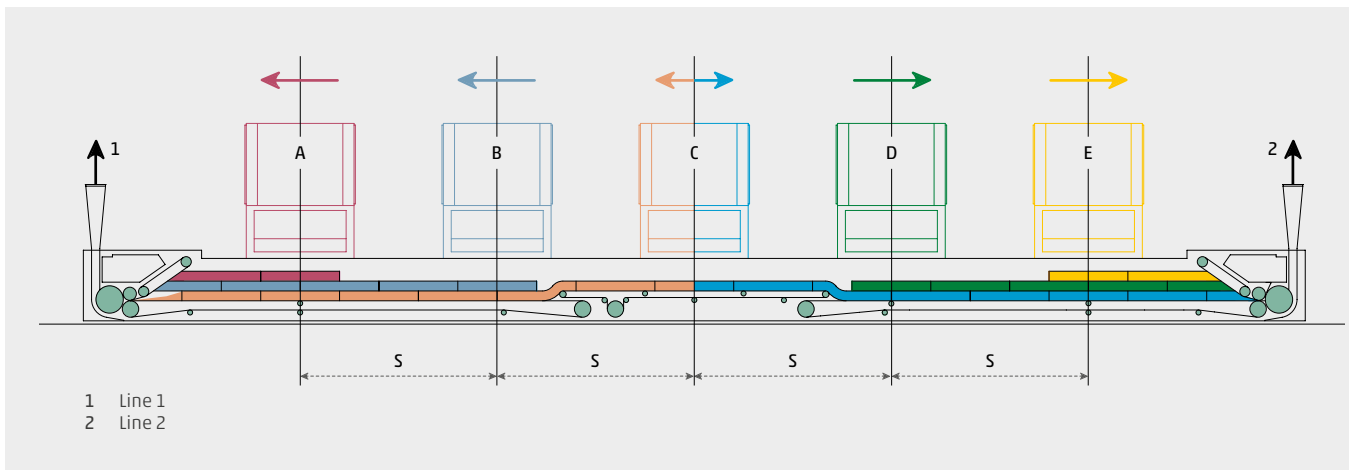

TECHNICAL DATA

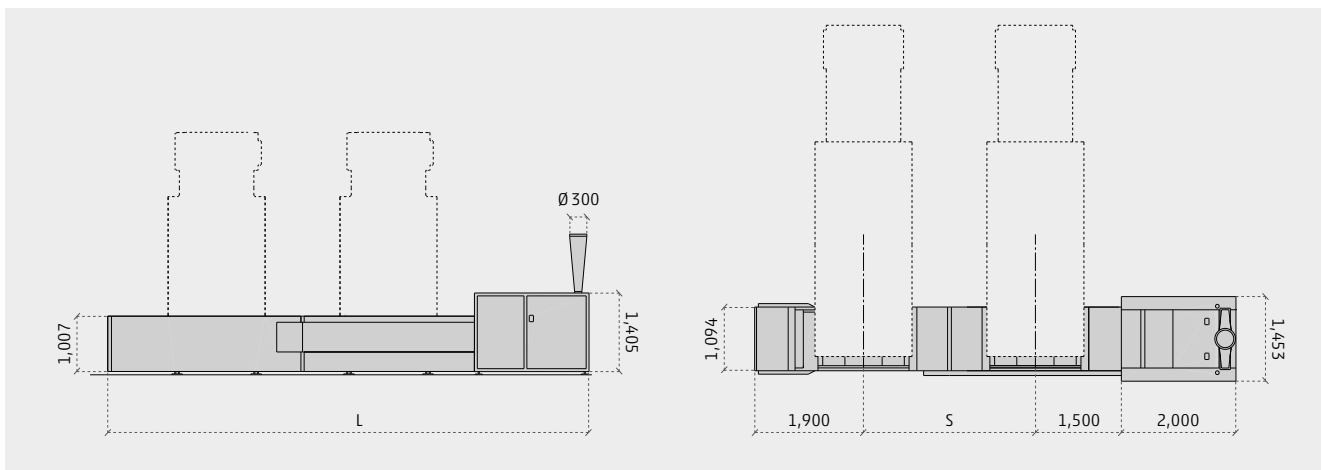

B23		Gauge S	3,000	4,200	5,400
Processed material	Cotton, man-made fibers and blends up to 1.000kg/h Production depending on the processed fiber	N° B13	L	L	L
Installed power	2.75 kW	2	8,400	9,600	10,800
Weight	From 2,210 kg to 4,110 kg according to the width	3	11,400	13,800	16,200
Power Consumption to process 100 kg of raw material	0.27 kW	4	14,400	18,000	21,600
		5	17,400	22,200	27,000

BALE OPENER B14 & PREMIXER

State-of-the-art opening technology for smaller productions

- Suitable for processing cotton and man-made fibers up to 65 mm (2 1/2") staple length;
- frame width: 1,200 mm;
- production: up to 600 kg/h with manual feeding;
- the length of the feed table can be adapted to the space available;
- it is advisable, from an economic point of view, to use the B14 bale opener and premixer when processing very small lots or when little space is available;
- the B14, in the version for cotton, is equipped with 11 adjustable knives grid and suction unit to eliminate the trash.

KEY POINTS

- PERFECT OPENING
- EFFECTIVE BLENDING
- PRODUCTION UP TO 600 kg/h
- IDEAL COMPROMISE BETWEEN PRODUCTION, COSTS AND SPACE NEEDED



MACHINE DESCRIPTION - LEGEND

- 1 Feed conveyor
- 2 Feed conveyor photocell
- 3 Feed lattice
- 4 Cage condenser
- 5 Material reserve trunk
- 6 Photocell
- 7 Delivery rolls
- 8 Roll clearer
- 9 Spiked lattice
- 10 Evener roll
- 11 Stripper roll

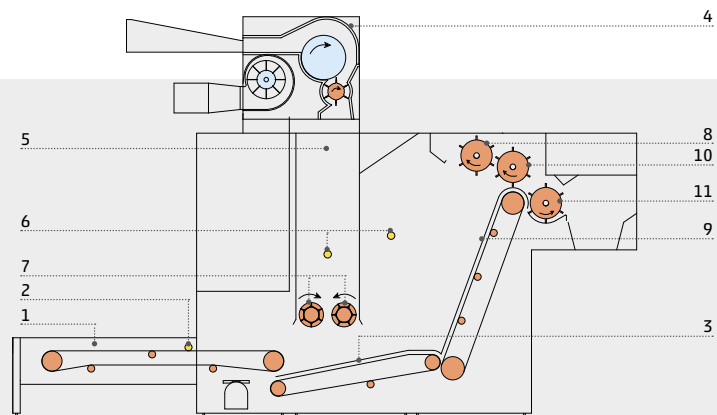

TECHNICAL DATA

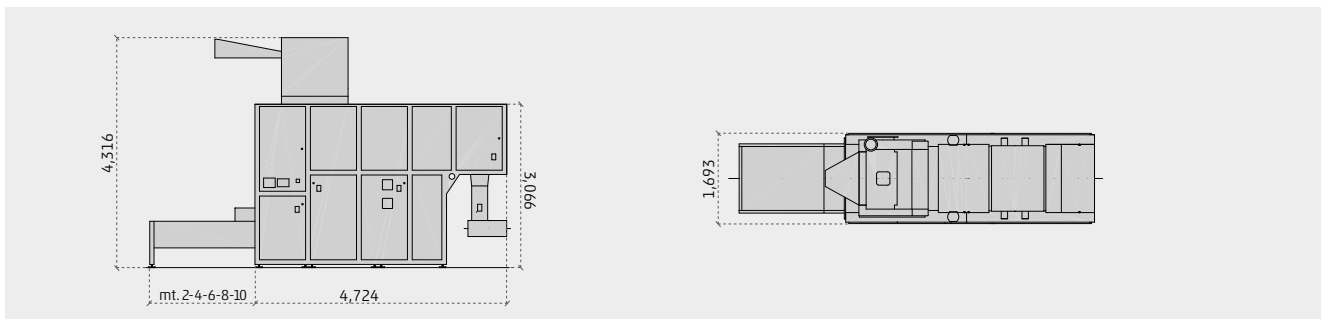

B14

Processed material	Cotton, man-made fibers and blends up to 600 kg/h. Production depending on the processed fiber
Installed power	4.43 kW excluding B450L
Weight	4,000 kg excluding B450L
Power Consumption to process 100 kg of raw material	0.44 kW

BLENDING FEEDER B15

The perfect feeder of recovered-fibers and small amounts of raw material



KEY POINTS

- PERFECT SOLUTION FOR RECOVERED FIBERS & SMALL LOTS
 - LOW INVESTMENT COST
 - HIGH EFFICIENCY
 - PRODUCTION UP TO 300 Kg/h
- The B15 blending feeder is the ideal solution to recover the good fiber that was discarded in downstream processes and to process little amounts of raw material.
 - High flexibility: easy to change from one material to another.
 - Production up to 300 kg/h as raw material feeder, 80 kg/h as recovered fiber feeder.
 - Feed conveyor from 2 to 10 meters.

MACHINE DESCRIPTION - LEGEND

- 1 Feed conveyor
- 2 Feed conveyor photocell
- 3 Feed lattice
- 4 Photocell
- 5 Spiked lattice
- 6 Evener roll
- 7 Stripper roll
- 8 Detaching roll

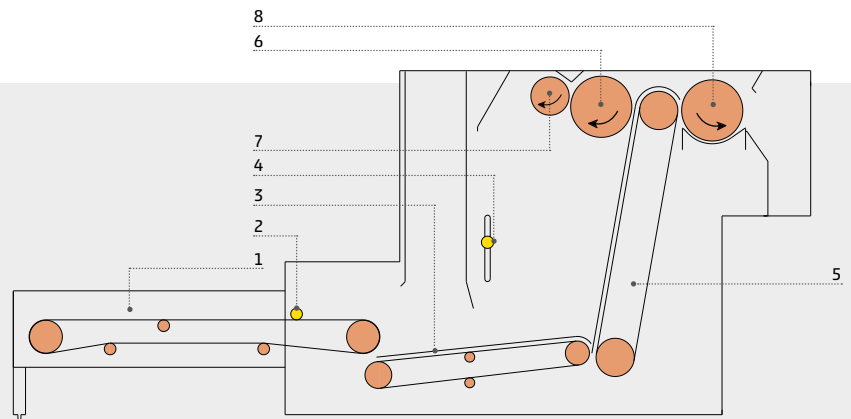

TECHNICAL DATA

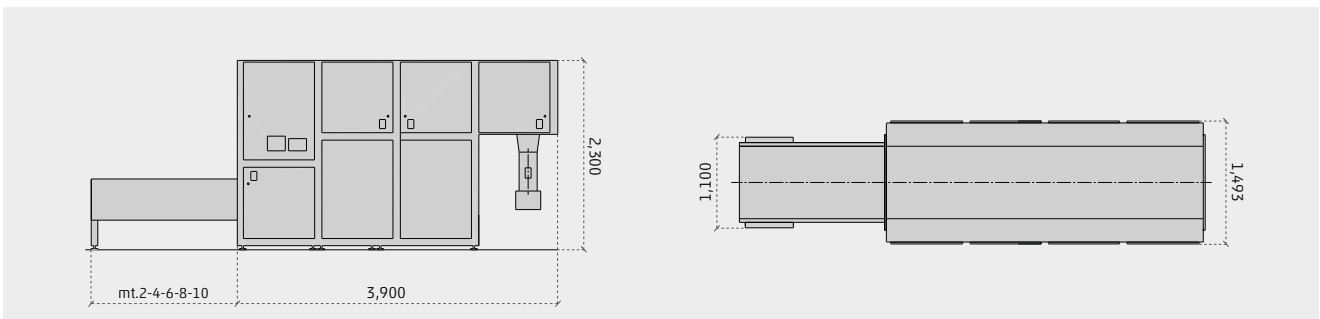

B15

Processed material	Cotton, man-made fibers and blends up to 300 kg/h. Production depending on the processed fiber
Installed power	3.12 kW
Weight	2,500 kg
Power Consumption to process 100 kg of raw material	0.91 kW

FEEDER B15 & OPENER B18

The best combination of feeder & opener for small lines

- Suitable to process cotton, man-made fibers and blends up to 65 mm (2 1/2") staple length;
- frame width: 1,000 mm;
- production up to 300 kg/h;
- The combination of the B15 feeder with the B18 opener constitutes a valuable and efficient solution to process man-made fibers and feed one or two cards simultaneously.

KEY POINTS

- HIGH INVESTMENT SAVINGS
- EFFECTIVE OPENING
- GREAT EFFICIENCY



MACHINE DESCRIPTION - LEGEND

- 1 B15 Blending feeder
- 2 B18 Opener

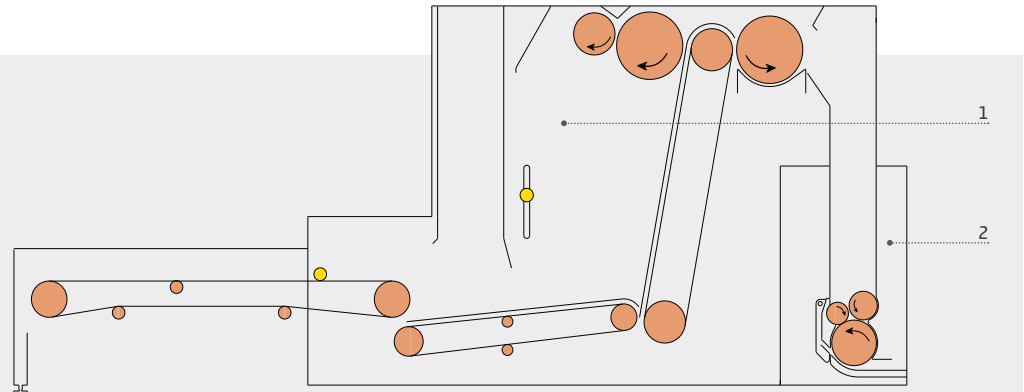

TECHNICAL DATA

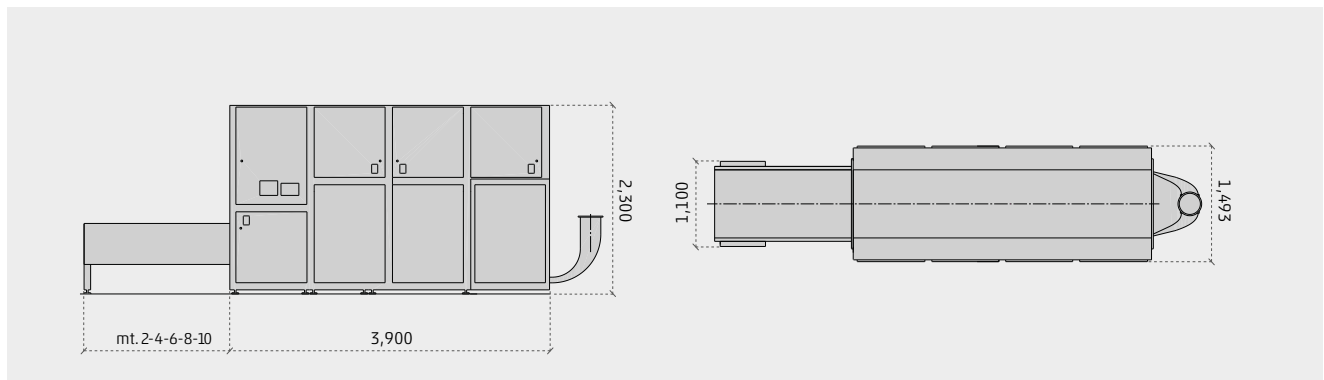

B15 - B18	
Processed material	Cotton, man-made fibers and blends up to 300 kg/h. Production depending on the processed fiber
Installed power	4.99 kW
bale opener B15	3.12 kW
Opener B18	1.87 kW
Weigth B18	620 kg
Power Consumption to process 100 kg of raw material	1.66 kW

OPENER FOR MAN-MADE FIBERS B134L

Efficient opener with throughput up to 1,600 kg/h

- Suitable to process cotton, man-made fibers and blends up to 65 mm (2 1/2") staple length;
- frame width: 1,600 mm;
- production: up to 1,600 kg/h;
- excellent approachability.

High flexibility

The B134L flexibility is obtained thanks to three interchangeable opening rolls:

- opening roll with 10,240 pins;
- opening roll with 14,880 needles;
- opening roll with sawtooth.

The opening roll is chosen according to the working material and the position of the machine in the process.

KEY POINTS

- PRODUCTION UP TO 1,600 Kg/h
- LOW INVESTMENT & PRODUCTION COSTS
- HIGH FLEXIBILITY

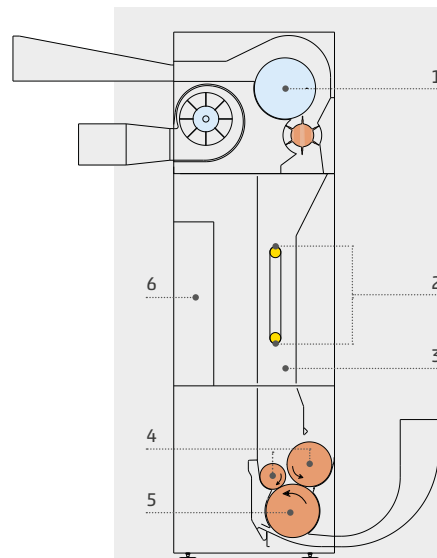

MACHINE DESCRIPTION - LEGEND

- 1 Cage Condenser B450L
- 2 Photocells
- 3 Chute feed
- 4 Feed rolls
- 5 Opening roll
- 6 Electronic Control Panel



TECHNICAL DATA

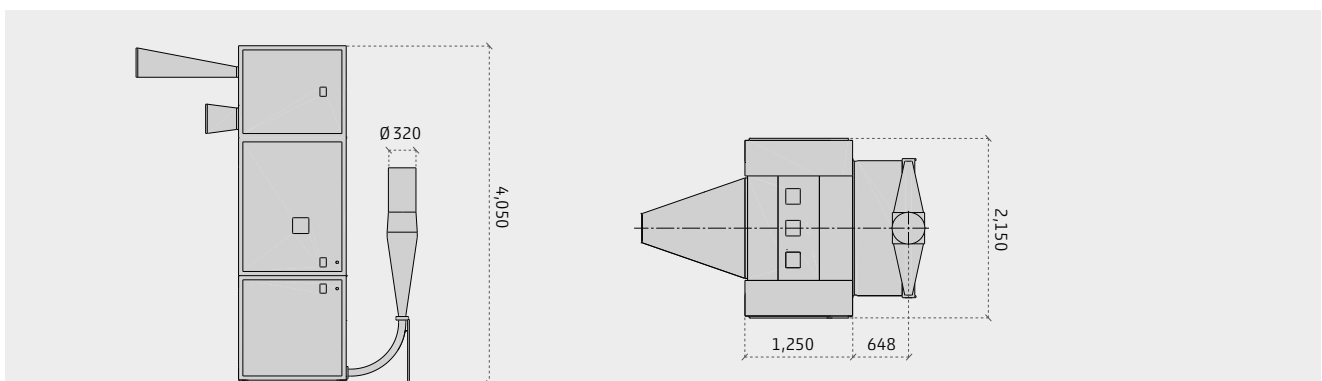

B134L

Processed material	Cotton, man-made fibers and blends up to 65mm. Production up to 1,600 kg/h depending on the processed fibers
Installed power	4.18 kW
Frame width	1,600 mm
Weight	3,400 kg
Power Consumption to process 100 kg of raw material	0.26 kW

CONTROL FEED & B153L

Card feeding system

The card feeding system is composed by a B450L dust separator and a B153L motor fan.

This system ensures constant and homogeneous feed to the cards.

- Cotton, man-made fibers and blends up to 65 mm (2 1/2") staple length;
- the controlled feed system is also adaptable to any other card.

MACHINE DESCRIPTION - LEGEND

- 1 Motorfan B152
- 2 Fine opener B380L or B134L
- 3 Dust separator B450L
- 4 Fan B153L
- 5 Pressure transducer
- 6 Control unit
- 7 Control feed duct
- 8 Chute feed C701

KEY POINTS

- HIGH INVESTMENT SAVINGS
- EFFECTIVE OPENING
- GREAT EFFICIENCY

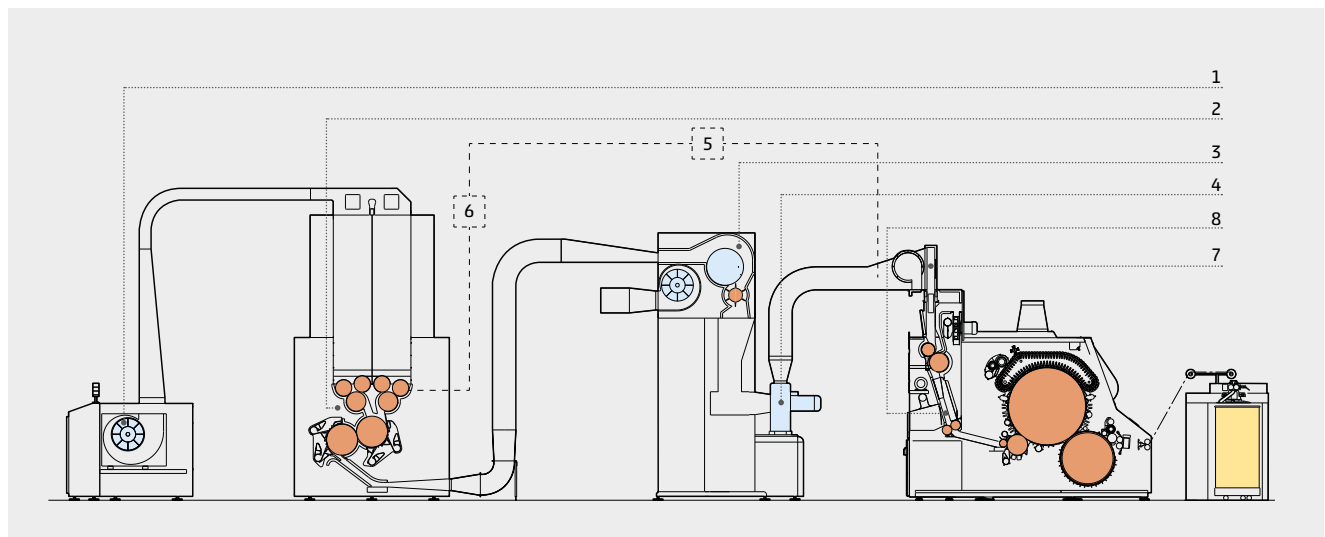

Motorfan B153L

Processed material	Cotton, man-made fibers and blends up to 800 kg/h. Production depending on the processed fibers
Installed power	4 kW
Fan diameter	425 mm
Fan speed	1,200 - 2,400 rpm
Air flow	Maximum 4,000 m ³ /h
Weight	100 kg

SOFTWARE PLATFORMS

END2END PRODUCTION MANAGEMENT PLATFORM: YARNET

YarNet is Marzoli production management software. It enables the monitoring of production levels, efficiency rates and downtime for both individual machines and the entire spinning mill. Comparisons between machines on selected periods of time are made very simple so that improvement opportunities can be easily identified. YarNet enables the operator to edit production recipes, downloading and uploading them between any machine and their computer. He can also export them in Excel format to share with colleagues as necessary. YarNet gathers and analyses data about production and energy consumption, giving a visual representation of the tradeoffs (kW/kg).

MRM

MRM is Marzoli software to continuously monitor the operating conditions of textile machines. It can identify developing malfunctions before a fault occurs and highlight improvement opportunities on efficiency rates and energy consumption levels. Data about temperature, power consumption, speed and vibration are collected from PLCs (programmable logic controllers) and sensors installed on each machine. The software verifies the monitored parameters are within the nominal operating ranges; it can even adjust for room temperature variations to ensure continuous optimisation. If any parameter is out of tolerance, an automatic email alert is sent to the customer. The customer can also access the dedicated online portal to see information for predictive maintenance and of the overall efficiency of the plant. Through dedicated modules (Optimisation Tools) it is possible to optimise the performance of every machine, in particular on energy consumption and levels of efficiency. If required, Marzoli's customer service team can access the data to diagnose actual and developing problems and recommend appropriate actions.

KEY POINTS

- EASY & FAST CONTROL OF EVERY STAGE OF THE SPINNING PROCESS
- IMPROVED SPEED OF RESPONSE IN PRODUCTION OPERATIONS
- EASY MANAGEMENT OF PRODUCTION RECIPES
- SUPERIOR, EASIER AND FASTER MAINTENANCE

YARNET

Marzoli Production Management

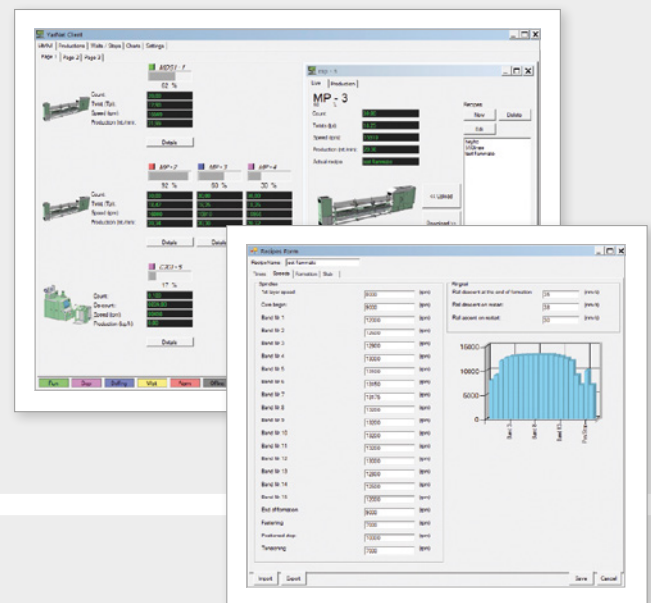

MRM

Marzoli Remote Maintenance

IoT Platform by Microsoft®

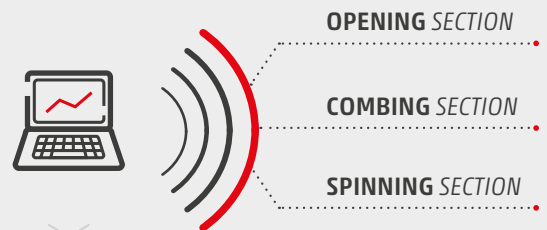

BENEFITS

- Higher productivity
- No machines unplanned downtimes
- Prevention from major machine failures
- Longer plant lifespan
- Higher efficiency
- Complete reliability
- Trouble free spinning experience
- Better maintenance planning

GALILEO BLOW ROOM LINES

Cotton with trash content up to 3%
Production 1,000 kg/h

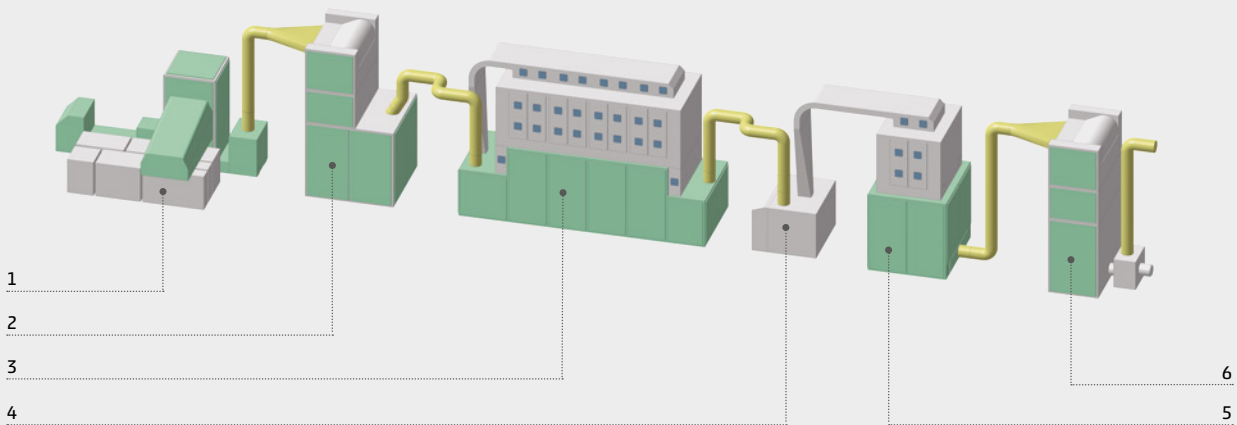

TECHNICAL DESCRIPTION - LEGEND

- | | |
|----------------------------------|----------------------|
| 1 B12 - 1,000 kg/h | 4 B152 - 1,000 kg/h |
| 2 B390L - 500+500 kg/h | 5 B380L - 1,000 kg/h |
| 3 B143L, 8 chambers - 1,000 kg/h | 6 B153L - 1,000 kg/h |

Blending	8 x 2 = 16
Cleaning efficiency	Up to 70%

Cotton with trash content up to 3%
Production 1,600 kg/h

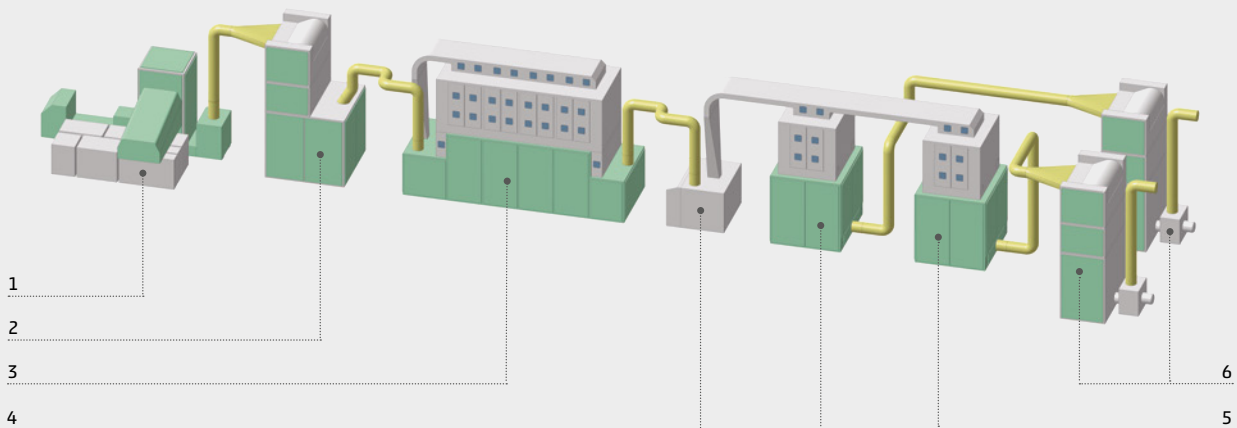

TECHNICAL DESCRIPTION - LEGEND

- | | |
|----------------------------------|---------------------|
| 1 B12 - 1,600 kg/h | 4 B152 - 1,600 kg/h |
| 2 B390L - 800+800 kg/h | 5 B380L - 800 kg/h |
| 3 B143L, 8 chambers - 1,600 kg/h | 6 B153L - 800 kg/h |

Blending	8 x 4 = 32
Cleaning efficiency	Up to 70%

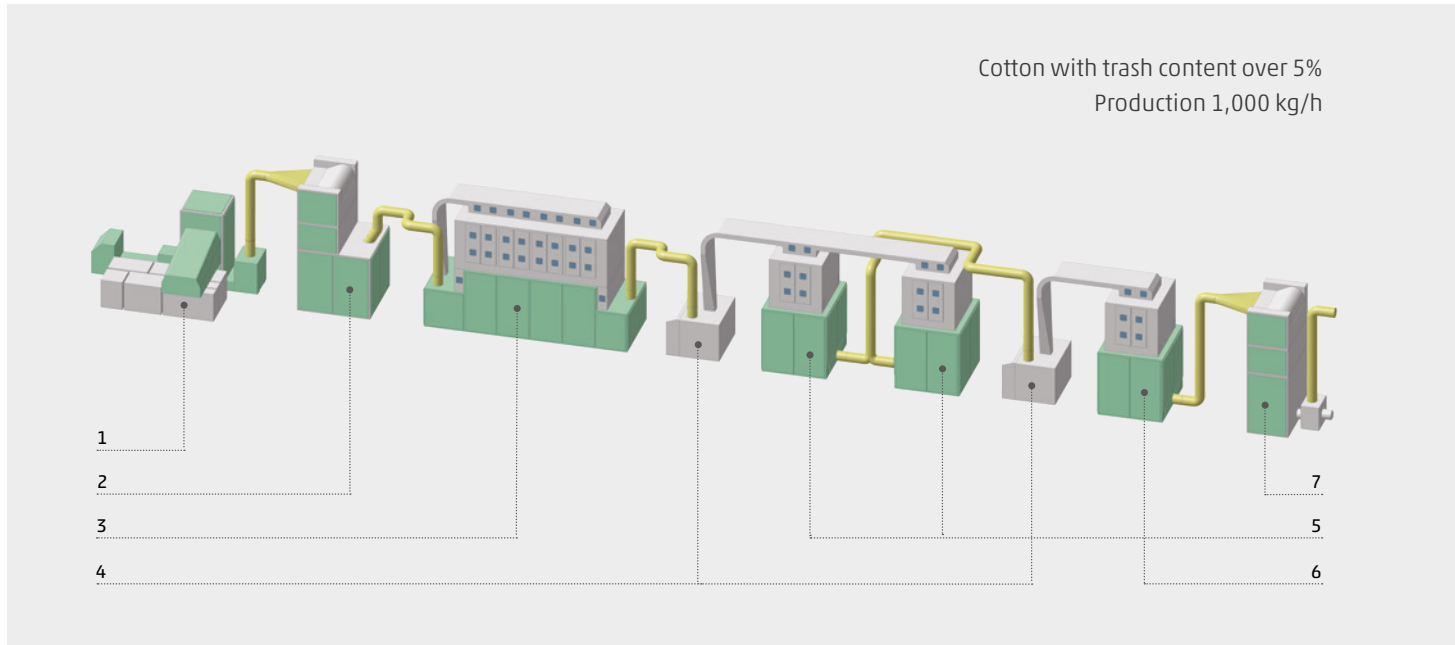

TECHNICAL DESCRIPTION - LEGEND

- | | |
|----------------------------------|----------------------|
| 1 B12 - 1,000 kg/h | 5 B380L - 500 kg/h |
| 2 B390L - 500+500 kg/h | 6 B380L - 1,000 kg/h |
| 3 B143L, 8 chambers - 1,000 kg/h | 7 B153L - 1,000 kg/h |
| 4 B152 - 1,000 kg/h | |

Blending	8 x 4 x 2 = 64
----------	----------------

Cleaning efficiency	Up to 80%
---------------------	-----------

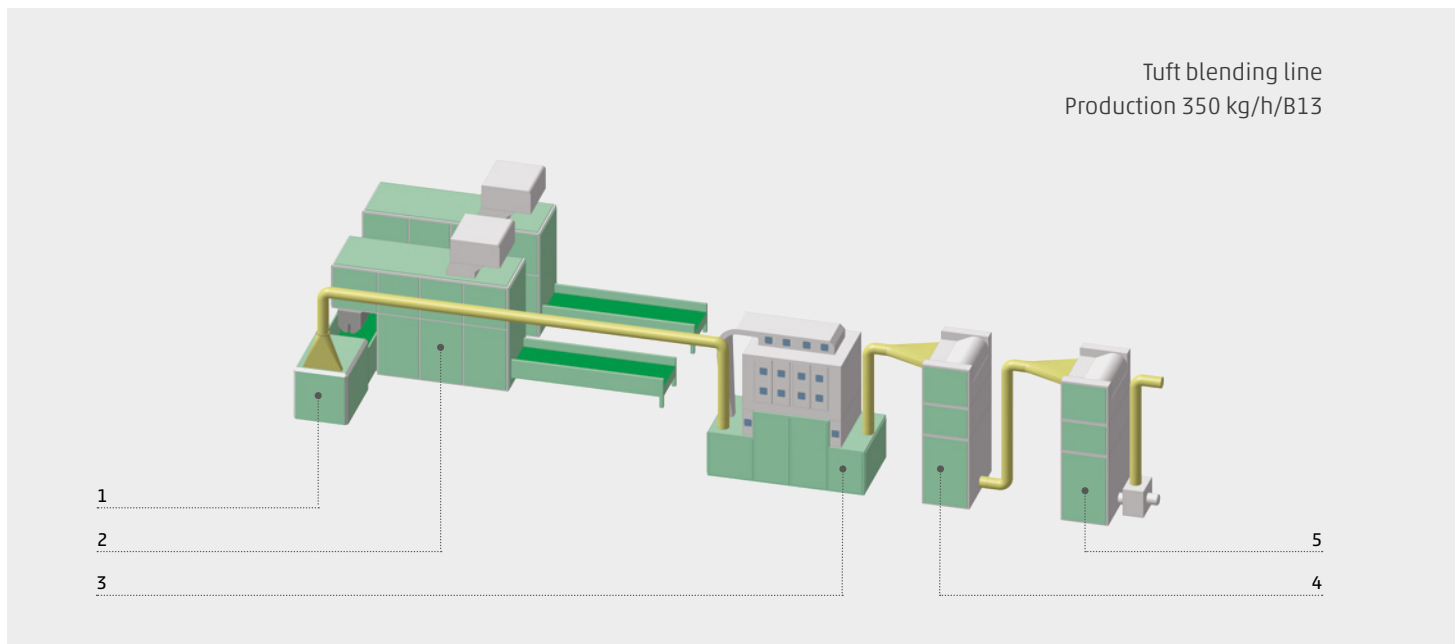

TECHNICAL DESCRIPTION - LEGEND

- | | |
|---------------------|---------|
| 1 B23 | 4 B134L |
| 2 B13 | 5 B153L |
| 3 B143L, 4 chambers | |

Tuft blending	Up to 5 components
---------------	--------------------

Blending accuracy	Discrepancy <1%
-------------------	-----------------

MARZOLI
INTERNATIONAL, INC.
USA

MARZOLI MACHINES
TEXTILE SRL
Italy

MARZOLI INDIA
MTMM PVT. LTD.
India

- Legend**
- Marzoli premises
 - Sales & service network
 - Sales affiliates

Marzoli Machines Textile S.r.l.
Via Sant'Alberto, 10
25036 Palazzolo sull'Oglio (BS)
Italy
Tel. +39 030 73091
sales@marzoli.it

Marzoli International, Inc.
100 Corporate Dr., Suite M
Spartanburg, SC 29303
U.S.A.
Tel. +1 864 599 7100
Fax +1 864 599 7111
sales@marzoli.com

**Marzoli India
MTMM Pvt. Ltd.**
Shed No 6, Bangalore Main Road
SIDCO Industrial Estate
Hosur - 635 126
Krishnagiri District, Tamil Nadu
India
Tel +91 4344 400111

MARZOLI
Textile Engineering

A Camozzi Group Company
www.marzoli.com