

P7300HP

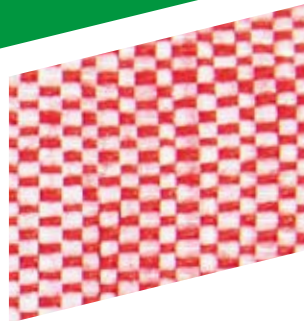

itema

P7300HP

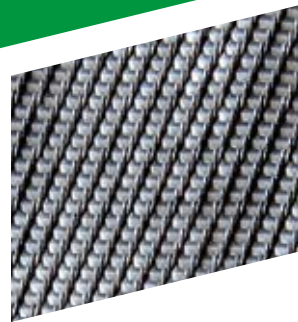
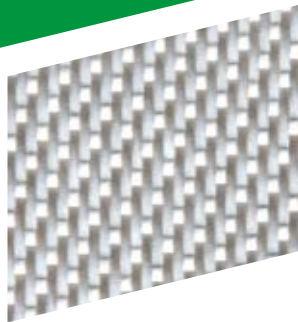
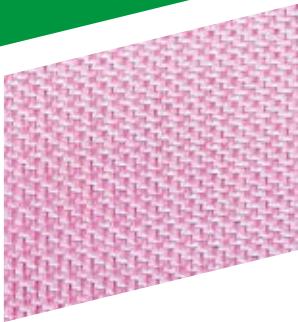
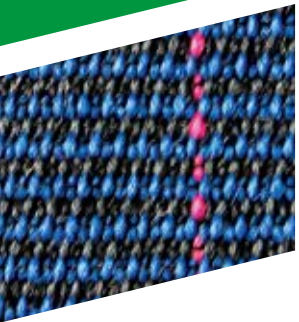
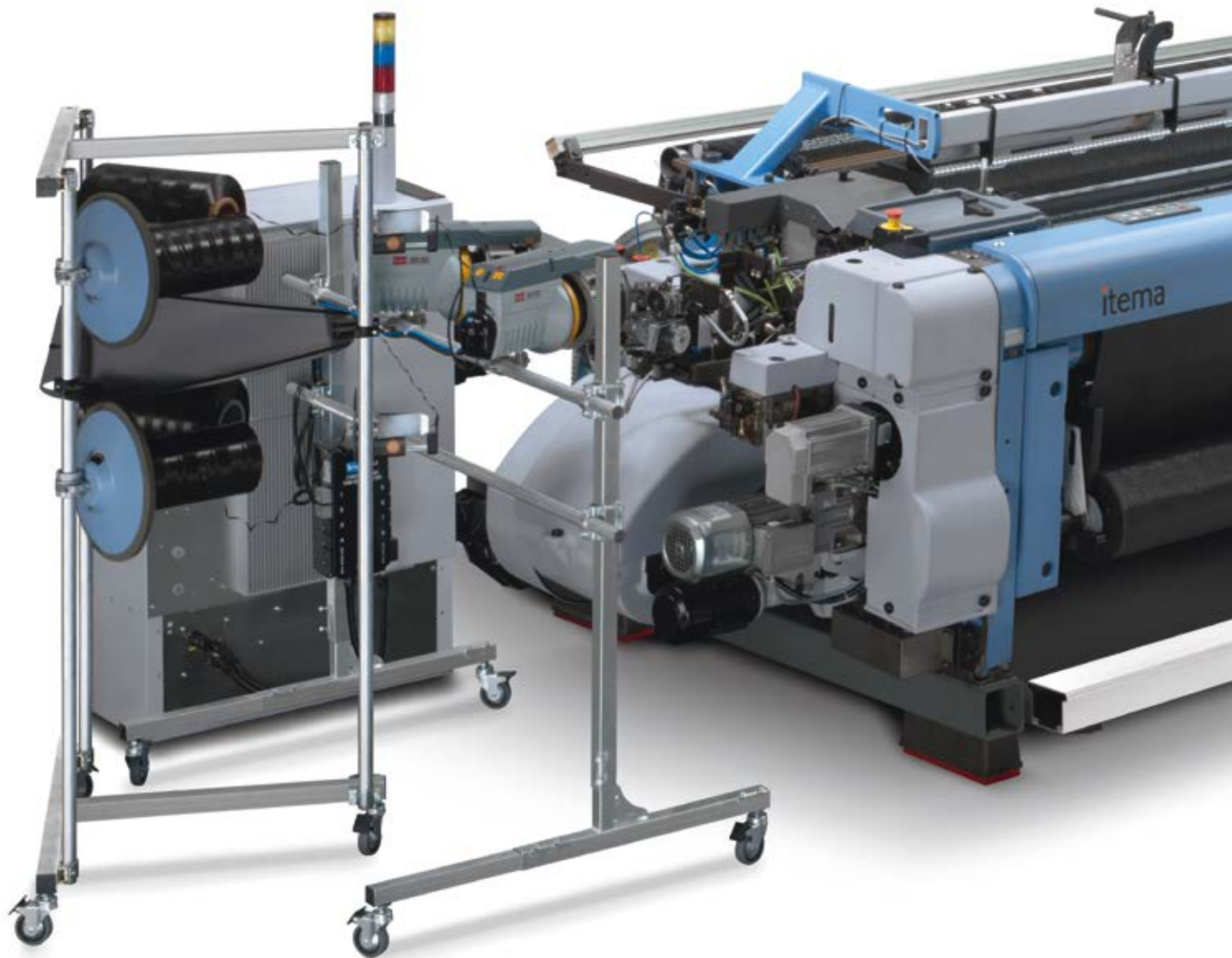



P7300HP

- Itema exclusive positive weft insertion system
- Sturdy and robust machine frame
- Unique weaving widths up to 655 cm
- Longest life span (over 50 years) unique in the weaving industry
- Highest fabric quality, low warp/weft stop rate, high flexibility on market needs
- Lowest yarn waste among all insertion technologies
- Unrivalled for technical textiles and high-quality denim
- Low spare parts consumption
- Low power consumption
- Easy operation
- High reliability



itema

P7300HP V8 Projectile Weaving Machine

Exclusive, unique, unsurpassed – the projectile P7300HP V8 is a timeless and unmatched technology and the choice of excellence for the most sophisticated weavers worldwide.

Itma is the only weaving machine manufacturer that offers the projectile weaving insertion system and this is for us a source of genuine pride. We are extremely satisfied to be the only producer to provide the market with this legendary weft insertion system, inherited from the excellence of Sulzer and continually improved in recent years through tireless technological advancements.

The Itma P7300HP is the essential choice for numerous weavers all over the world who opt for the undeniable advantages of this machine when it comes to fabric quality, machine reliability guaranteed by the exclusive weft insertion technology.

The working width, available in nine standard versions up to 655 cm, coupled with the machine robustness, which guarantee the longest life span in the weaving industry, set the projectile weaving machine apart from competition. Low power consumption adds to P7300HP's reputation as a great overall investment.

These unique features are further strengthened by the technical advancements implemented on the P7300HP, which make this weaving machine a cutting-edge and modern weaving machine perfectly fitting the current and future needs of our Customers.

The shed geometry together with the optimized sley movement ensure top fabric quality, effectively avoiding start marks, even weaving delicate fabrics.

Furthermore, the P7300HP combines top productivity thanks to quick style changing, easy programming and outstanding reliability.

When it comes to weaving premium fabric quality, exceeding market expectations and making a sound investment in an excellent, reliable and unrivalled weaving machine, we have the right technology for you: the projectile P7300HP.

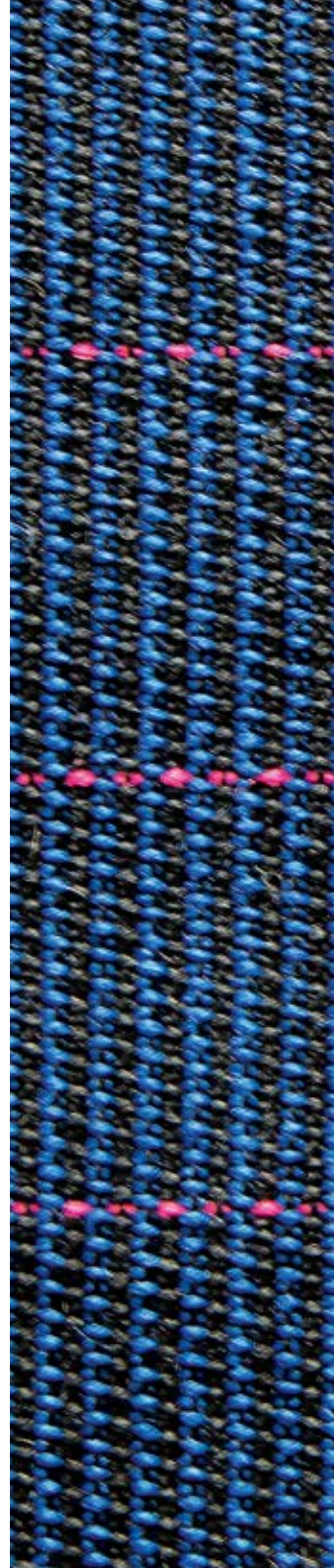

P7300HP

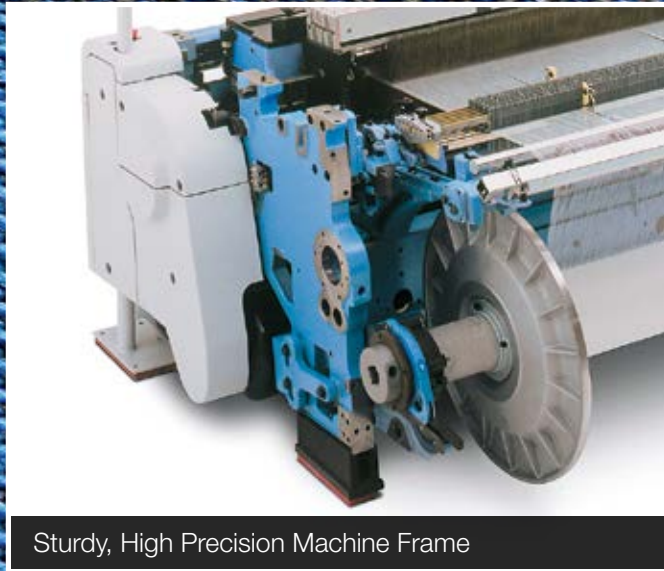

Sturdy, High Precision Machine Frame

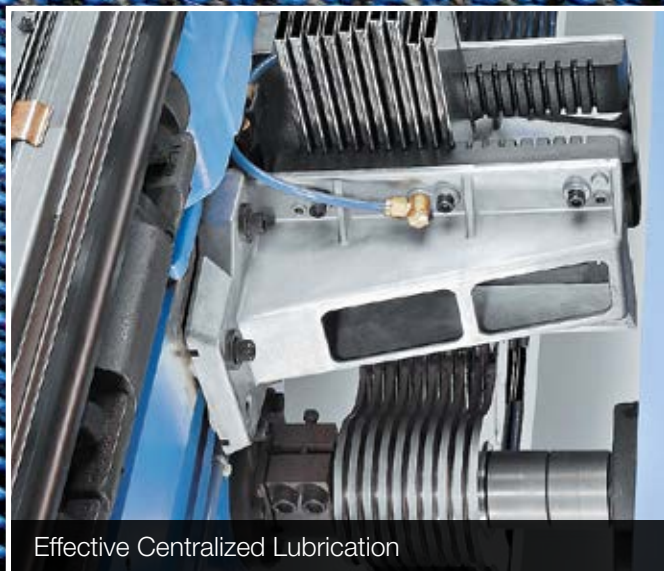

Effective Centralized Lubrication

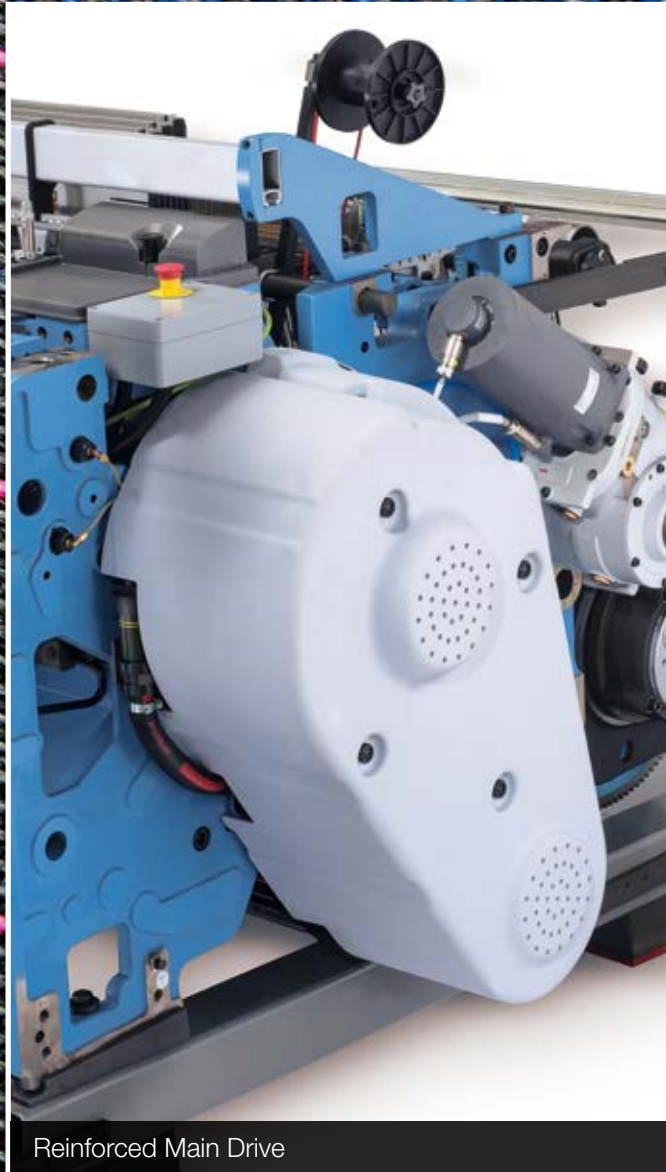

Reinforced Main Drive

High performance, reliability and exclusive advantages

Sturdy, High Precision Machine Frame

The P7300HP is the ultimate in sturdy machine concept, made with side heavy-duty frames, built to bear high loads. The machine's stability and reliability are further increased thanks to an additional cross support. These features ensure the machine's low vibration, allowing less wear and tear and guaranteeing the well-known excellence of textiles woven on projectile weaving machines.

Unique Weaving Widths

The P7300HP is available in nine working widths, from 220 cm up to 655 cm. It is the only weaving machine in the market for which 655 cm is a standard width — a real advantage in many applications, and especially so in the production of technical fabrics where the P7300HP enables weaving agrotexiles and geotextiles in larger widths, requiring fewer or no seams.

On models with large working widths, the efficiency of the P7300HP is further increased by its ability to weave several fabric runs of the same or different widths simultaneously. As a result, the maximum weft insertion rate is attained at lower machine speeds, thus reducing machine wear, lowering space requirements and saving electricity.

The benefits offered by the P7300HP projectile weaving machine are multifaceted and include:

- lowest power consumption of all weaving systems
- tucked selvedges
- no warp and weft material wastage
- quick warp and style changing
- low spare parts consumption
- high reliability
- oil bath-immersed, practically maintenance-free sub-units, to name just a few.

Effective Centralized Lubrication

Machine components are lubricated by a centralized unit that enables the individual lubrication of several aggregates. The lubrication system is adjustable through the terminal and can be reproduced on all machines allowing an easy and smooth setting.

The fixed cycle, with minimal lubrication due to rotating pistons and oil flow control through bypass screw, is active only when the part to be lubricated is in line with the lubrication outlet, thus ensuring low operating costs and better fabric quality thanks to reduced oil consumption and fabric soiling.

Centralized automatic greasing system controlled through the terminal reduces further the maintenance work on the machine.

Reinforced Main Drive

The electro-magnetic machine brake and the pneumatically driven machine clutch with automatic pressure control allow a consistent reduction of the load on the weaving machine during the stop phase. The overall system is optimized to have less mechanical strain on the whole machine, leading to low maintenance and reduced spare parts costs.

The Longest Life Span

The projectile P7300HP is the only weaving machine in the market which can claim the longest life span, with an average of over 50 years. The solidity of the machine and the sturdiness of its components guarantee low maintenance costs and an excellent lifespan of the machine.

P7300HP

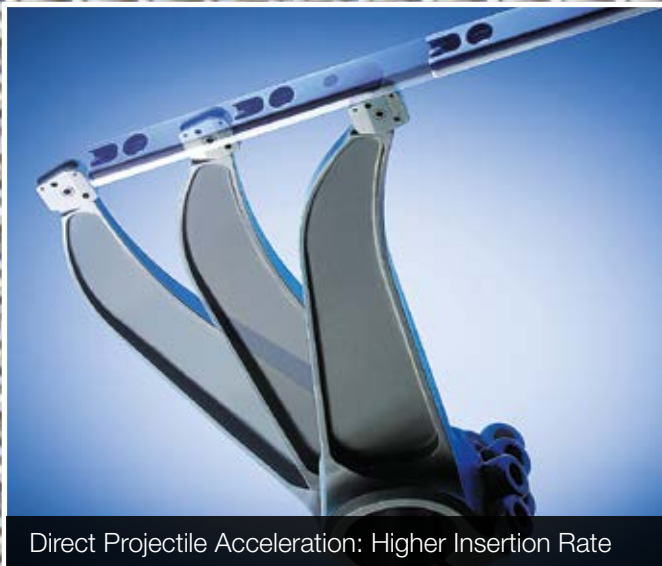

Direct Projectile Acceleration: Higher Insertion Rate



Adaptive Selvages to Minimize Yarn Waste



Projectile Weft Insertion: Reliable and Controlled



A unique, exclusive weft insertion system

Direct Projectile Acceleration: Higher Insertion Rate

The projectile P7300HP is a high-performance weaving machine in which optimized motion sequences and direct projectile acceleration result in a weft insertion rate of as much as 1570 m/min.

Projectile Weft Insertion: Reliable and Controlled

In the P7300HP the weft is guided in a positive controlled manner in every phase of weft insertion: from weft transfer to the projectile, passing through insertion into shed, all the way through to beat-up.

The projectile weaving machine reliably grips a wide variety of threads, tapes or monofilament yarn and inserts them into the shed. Reflecting the varying requirements for different weft yarns, projectile grippers with various clamping forces and surface areas are available.

One outstanding feature of projectile technology is that the weft is inserted without central transfer, avoiding additional acceleration and braking.

With this unique insertion technology, the P7300HP inserts all weft yarns in a guided and controlled way with minimum yarn stress, ensuring maximum reliability in the production of high quality fabrics.

The new main drive of the P7300HP is a further point of excellence, since it requires considerably less servicing and maintenance thanks to the pneumatic clutch pressure system.

The Weaving Machine for Tomorrow's Needs

The versatility of the P7300HP is unrivalled, both in its standard equipment and in the many optional extras available. With accessories tailored to the application it can be customized to meet the weavers' exact needs.

With the P7300HP you are investing in a future oriented, upgradeable weaving system. Thanks to its modular design, the machine can be adapted at low cost to meet new requirements. Thus it is a machine that can "grow" with your customers' needs. Expanding the color selector from two to four is just as simple as switching from tappet motion to dobbie for shed formation.

P7300HP

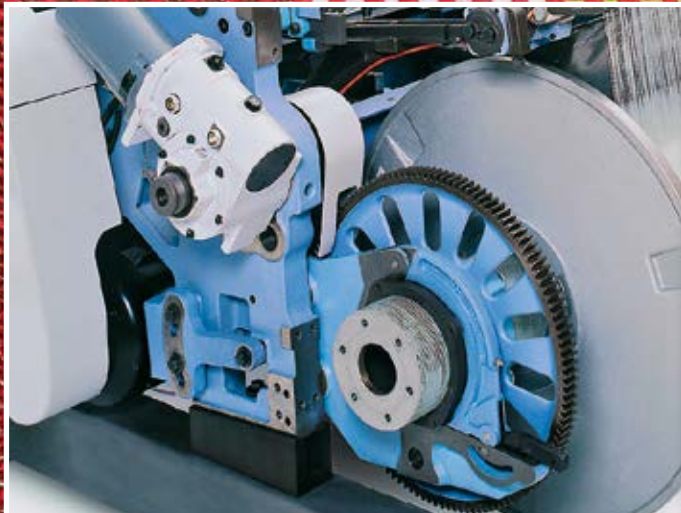
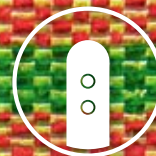

Optimized Warp Let-Off and Fabric Take-Up



No Limits to Fabric Patterns:
Quick and Easy Setting of the Shed

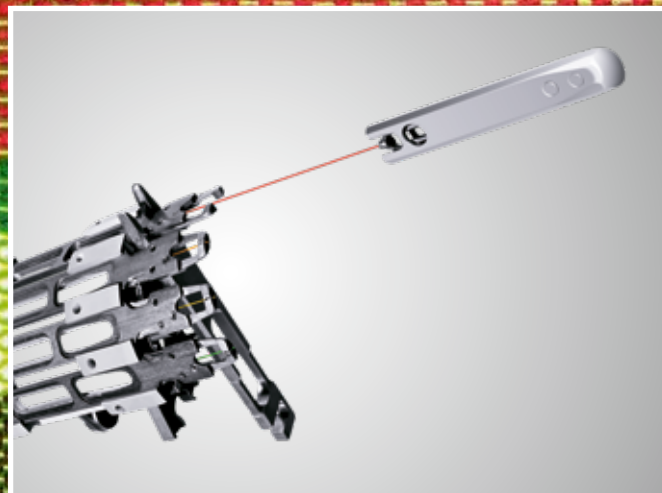

No Limits to Fabric Patterns:
Color Selector Up to 4 Weft Colors

Quality, versatility, reliability: the P7300HP keywords

Adaptive Selvedges to Minimize Yarn Wastage

In both single and multi panel weaving, every selvedge can be tucked by lateral or intermediate tucking units. The width of the tucked selvedges can be chosen from 18 mm and for special applications up to 35 mm. Accurate weft measurement ensures zero yarn wastage. Instead of tucking units, the P7300HP can be equipped with devices for producing leno or melted selvedges. In the case of leno selvedges, the Selvedge Saver feature eliminates auxiliary selvedges, thus saving warp and weft yarn, further maximizing efficiencies for the weaver.

Optimized Warp Let-Off and Fabric Take-Up

The interplay of shed formation, warp and weft run is crucial for a flawless appearance of the fabric. By entering just a few data points at the terminal, the fabric take-up, shed leveling and warp let-off are optimally coordinated. In this way, start marks are reliably and effectively avoided, even when working with the most delicate fabrics.

The warp let-off is electronically driven, ensuring constant warp tension from the beginning to the end of the warp. With wide weaving machines or when using

two half warp beams, the machine is equipped with two warp let-off devices. The warp tension of each warp let-off is controlled by separate sensor systems.

Moreover, a variety of back rest roller and fabric take-up systems are available to suit the density and type of the fabric being woven.

The weft density is adjustable in steps of 0.1 picks per cm.

The fabric take-up, electronically controlled, with a take-up and press roller is standard equipment on the P7300HP. The floating take-up roller ensures reliable take-up even for heavy fabrics.

A decisive feature for the fabric quality is provided by the new force sensors in the warp tensioner which guarantee a perfect control of warp tension.

No Limits to Fabric Patterns

Shed formation can be fitted with either a tappet motion with up to 14 heald shafts or an electronically controlled dobby with up to 18 heald shafts. In combination with the color selector, which can handle up to 4 weft colors, there are practically no restrictions or limits when it comes to weaving in practice the best of your designers' imagination.

Minimum Maintenance Costs, Maximum Benefits

In servicing and maintenance, the P7300HP sets new benchmarks of efficiency and low-cost operation. Substantially longer servicing and oil change intervals reflect the machine's outstanding reliability and cost-efficiency. The reduced number of different lubricants saves costs through simplified logistics. All joints in the shaft drive have permanently lubricated ball bearings. Furthermore, low maintenance shaft drives (under motion) with permanently lubricated ball bearings bring the additional benefit of the high flexibility for quick and easy style changes.

The lifting levers are lubricated with grease. The new casing prevents accumulation of dust and is easy to clean.

Practical mechanical and electronic safety components provide maximum protection for operating personnel.

P7300HP

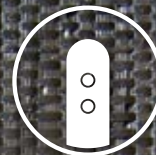

No Compromises on Fabric Quality



Leading Technology for Technical Textiles and Denim



Ace of Quality

No Compromises on Fabric Quality

In developing the P7300HP, top fabric quality was our paramount goal. We achieved it with a new shed geometry and an optimized sley movement.

The Itema projectile P7300HP produces fabrics of supreme quality, from all raw materials and for all applications. With a weft insertion rate of up to 1570 m/min, it is outstandingly cost-efficient.

With the P7300HP you can fulfil your Customers' varying requirements with precision and a tailor-made approach. The famous projectile weft insertion technology is suitable for any weft material: spun yarns made of natural and manmade fibers, filaments or tapes.

Leading Technology for Technical Textiles and Denim

When it comes to weaving technical textiles and high quality denim fabric, the Itema projectile P7300HP is the best choice in the market.

For decades, projectile weaving technology has been acclaimed as the leader in technical textiles production, from the finest filter fabrics (bolting) up to ultra-heavy coating fabrics (conveyor belts), all in outstanding quality. In the production

of fabrics from polypropylene tapes, for big bags, carpet backing, geotextiles or agrotexiles, the projectile weaving machine excels with unparalleled economy and quality.

Denim fabrics are produced worldwide and with great success on our projectile weaving machines. One outstanding feature of the projectile technology is the exclusive opportunity to weave also the heaviest denim fabric, up to 14 1/2 oz., thus allowing the weaver to unleash his or her creativity in producing high quality denim.

Projectile Machine For Special Applications

The Itema unique projectile insertion system can be customized and reinforced to provide the perfect solution to weave extreme dense woven fabrics — up to 15'000 N/m, reed beat-up force — for filtrations, conveyors belts, geo-reinforcement.

P7300HP



State of the Art Technology



Integration in Networks to Optimize the Weaving Process



Full Color Touch Screen

Top marks in user-friendliness

State of the Art Technology

The perfect interaction of a technologically mature design and cutting-edge computer technology puts the P7300HP in a class of its own. Its versatility and fast adaptability further enhance the great overall investment thanks to the opportunity to tailor the machines to your demanding weaving needs in just a few moves.

The P7300HP combines top productivity thanks to quick style changing, easy programming and high speed, as well as outstanding reliability.

Integration in Networks to Optimize the Weaving Process

Corporate integration in local and global networks can sometimes be a big challenge for the textile industry. Itema's answer: control systems architecture embedded in our weaving machines.

Fast responsiveness while maintaining high fabric quality are the essential pre-conditions for gaining and maintaining competitive advantages in the rapidly evolving global marketplace. In order to satisfy these demanding criteria the new projectile weaving machine has been equipped with a pioneering weaving machine control system.

In the P7300HP, latest generation micro processors with Canbus control, monitor and regulate all major machine functions, thus ensuring consistently high quality throughout the weaving process.

Full Color Touch Screen

A touch-screen terminal is the clear, user-friendly, man-machine interface. This user interface is based on internet browser technology. Thanks to ergonomically arranged keys with clear, easy to understand symbols, operation of the P7300HP is simplicity itself.

Besides machine parameters and pattern data which can be programmed at the terminal or transferred via production management systems and USB key, also statistical, help and diagnosis functions are available to simplify operation.

These functions include:

- automatic adjustment of the weft detector
- optimal adjustment of the projectile brake
- semi-automatic warp pull-through with synchronized drives
- extended statistical functions
- simple, accurate diagnosis
- additional help functions.

P7300HP



Weaving width

2200 mm
2800 mm
3300 mm
3600 mm
3900 mm
4300 mm
4600 mm
5400 mm
6550 mm

Machine width (A)

4780–5060 mm
5410–5700 mm
5920–6200 mm
6250–6540 mm
6510–6790 mm
6900–7170 mm
7290–7570 mm
8030–8310 mm
9140–9420 mm

Overall depth (B)

2000–2300 mm
2000–2300 mm
2000–2300 mm
2000–2300 mm
2000–2300 mm
2000–2300 mm
2000–2300 mm
2000–2300 mm
2000–2300 mm

Depending on machine equipment.

Without mobile warp beam step, but including deflection roller. Depending on warp beam diameter and cloth beam winding.

Layout drawing

only applicable to P7300HP
with EP and SP

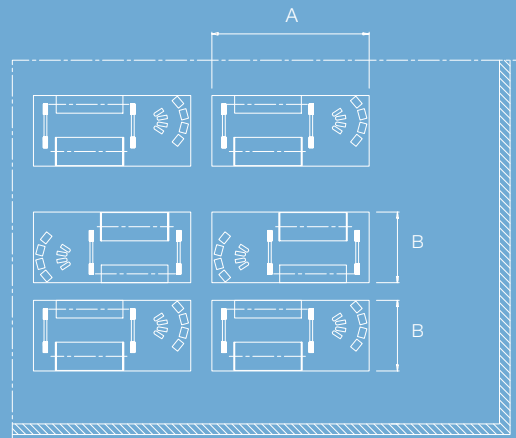

Dimensions (mm)

P7300HP V8

B**360****N****4****EP****D12****R**

Raw Materials

- B *Cotton*
- S *Synthetics (filament yarns)*
- W *Wool*
- P *Polypropylene*

Nominal Machine Width (cm)

220, 280, 330, 360, 390, 430, 460, 540, 655

Design

- N *low-build weaving machine (without healdframe superstructure)*

Weft Colors

- 2 *two-weft colors, pick sequence control with electronically controlled magnet*
- 4 *four-weft colors with electronic pick sequence control*

Shedding

- EP *positive tappet motion max. 14 heald frames*
- SP *positive dobby, electronically controlled max. 18 heald frames*
- J *Jacquard machine, electronically controlled*

Projectile Circuit

- D12 *steel projectile with small cross-sectional area and large clamp*
- D2 *steel projectile with large cross section area for heavy yarns*

Supplementary Equipment

- R *equipment for weaving heavy fabrics*
- RSP *equipment for weaving heavy and dense fabrics*
- R3 *equipment for weaving extremely heavy and dense fabrics*

Another perspective

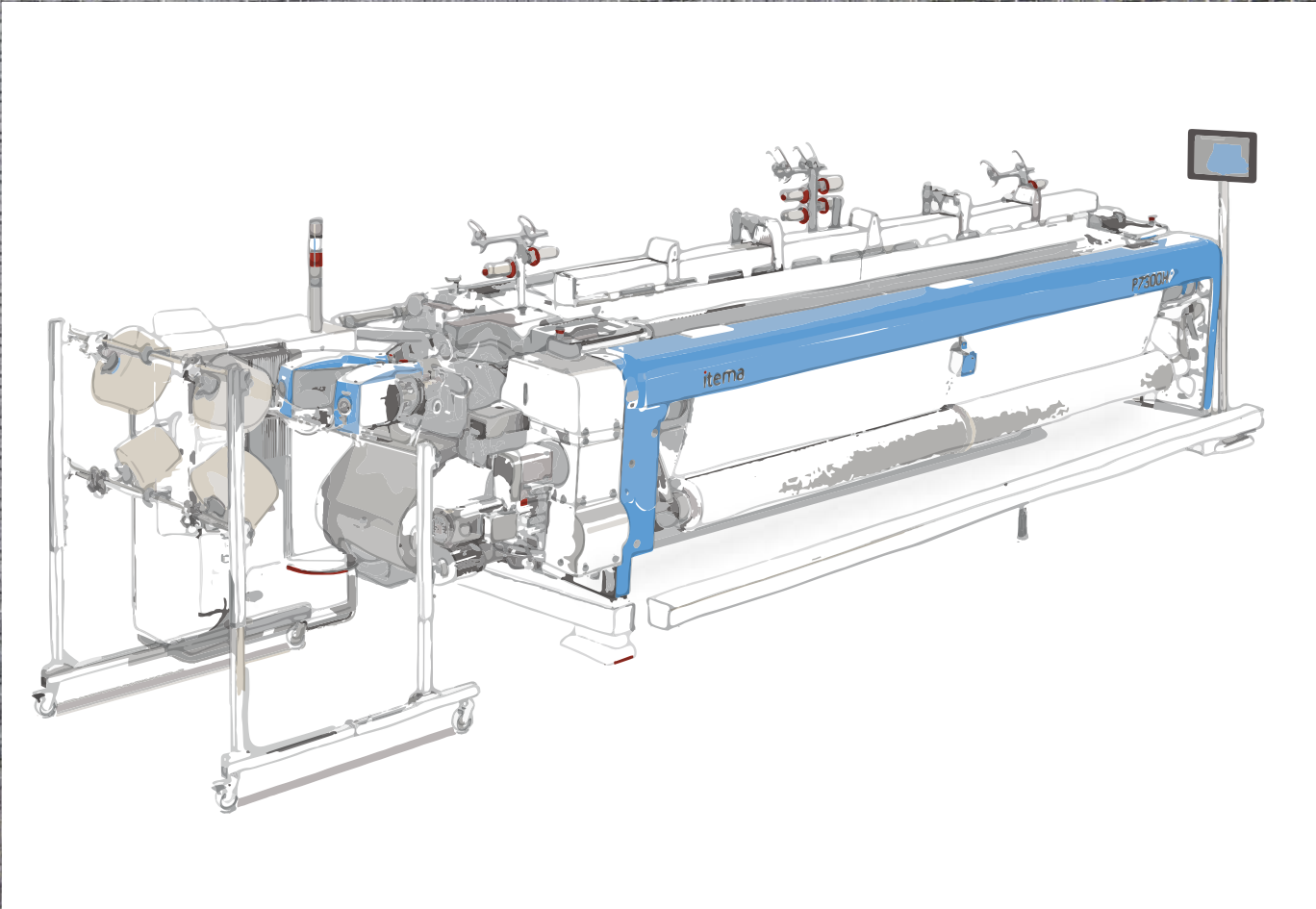

P7300HP



Unique weft insertion system. Ideal for technical fabrics, premium quality denim, wide width applications.



PROJECTILE



feel the future

Specifications subject to change without notice. 43.136.09 Bar - EN



www.itemagroup.com
contact@itemagroup.com

itema

Italy · Switzerland · China · Hong Kong · India · Japan · USA · Dubai

