

OVERVIEW



Textile Engineering

## **GALILEO - FT6E & FT7E** **ROVING FRAMES**



**Marzoli**

Complete spinning line,  
components and digitalized  
solutions for the best performance  
of the spinning process





# THE ONE SOURCE FOR A FULLY-AUTOMATED AND DIGITALIZED SPINNING MILL

Marzoli, one of the major brands of the textile sector worldwide, is a unique European manufacturer of the complete line of machines for the opening, preparation and spinning of short-staple fiber. From the bale opener to the ring spinning frame, Marzoli offers the most advanced technology for a completely-automated spinning mill. Through its global sales and service network, its expertise on each type of fiber and application and the competence on the entire process, Marzoli represents a competent and reliable partner. And through its experience, know-how and commitment, it provides its customers with:

- Advanced spinning solutions through a careful activity of textile engineering. Marzoli assists its customers from the study of the spinning plan, throughout sourcing, erection and commissioning, up to maintenance of the resulting turnkey spinning plant, which can comprise Marzoli but also third-party machinery. The customer can rely on the competence and capability of a unique partner, responsible for the quality and productivity of the entire spinning mill.
- The advantages of smart spinning. No matter what the brand(s) of the machinery is, Marzoli can install its software platforms, YarNet and MRM, its hardware applications for gathering data on waste percentages and its composition, quality values, productivity indexes and other kpi data to let the customer build on the potential of Industry 4.0, optimize the entire spinning process through well-informed decisions and reach the highest performance in production operations.

OVER  
**160** YEARS  
OF SUCCESSES

OVER  
**70** COUNTRIES  
WITH ACTIVE CLIENTS



#### OPENING SECTION

- Openers & Cleaners
- Mixers & Blenders
- Card

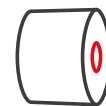

#### COMBING SECTION

- Draw Frames
- Lap Winder
- Comber
- Lap Transport



#### SPINNING SECTION

- Roving Frame
- Ring Spinning Frame
- Bobbin Transport System

# STATE OF THE ART TECHNOLOGY FOR ROVING PRODUCTION

## KEY POINTS

- INDEPENDENT DRIVES
- UP TO 240 SPINDLES
- RELIABLE STOP IN CASE OF ROVING BREAK
- NO SUCTION NECESSARY
- 3 OPTIONS FOR DOFFING



Marzoli FT6E and FT7E are a fully-updated version of its market-leading roving frames. Equipped with all the most advanced technology, they represent technological excellence for productivity and efficiency.

The drives for the drafting system, the flyers, the spindles and the bobbin rail are independent and coordinated by the central CPU. This simplifies the machine, guaranteeing perfect coordination, reducing the number of components, lowering friction, vibrations and mechanical wear.

The higher number of spindles, the FT6E and FT7E roving frames can respectively reach 240 and 192 spindles, allows to reduce investment and operational costs while boosting productivity per machine.

The roving sensors, one for each spinning position, (option) allow to immediately detect any roving breakage and promptly stop the machine, even in case of roving overlap. This makes suction not necessary: the machine can be supplied without suction box (option) and the client can save up to 4 kWh per machine.

The FT6E and FT7E roving frames present 3 different options for doffing: semi-automatic doffing, fully-automatic doffing, pre-arrangement for automatic doffing upgrade.

In the semiautomatic version the bobbin rail lowers and tilts out for easy bobbin collection; there is also a parking for empty tubes just in front of the rail for easy replacement.

In the fully-automatic version full bobbins are collected by the doffer rail and forwarded to the transport system. Empty tubes are inserted on the spindles and brought into working position before the machine restarts. All these operations are carried out automatically, with no human intervention, in less than 3 minutes.

The roving frame with pre-arrangement for the automatic doffing upgrade is a whole new option. Although very similar to the semi-automatic one, this version allows to undertake a cost-efficient upgrade to the fully-automatic version at any time.

## MACHINE DESCRIPTION

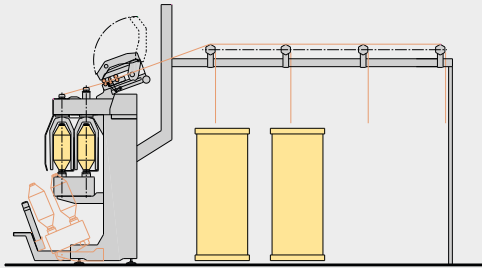

Roving frame with semiautomatic doffing

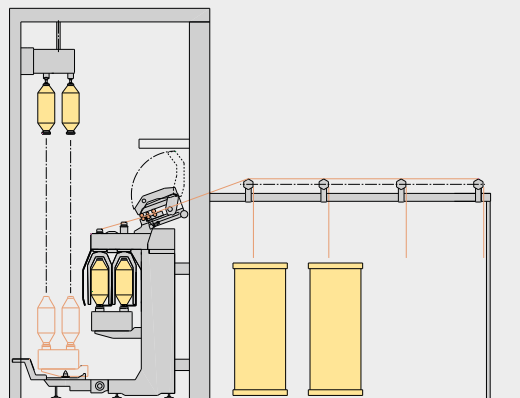

Roving frame with automatic doffing

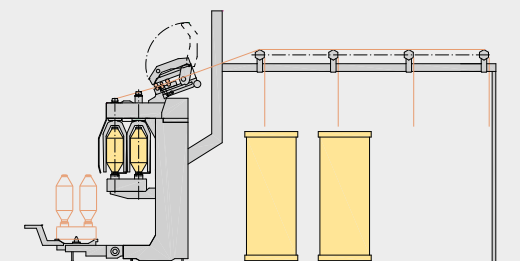

Roving frame with pre-arrangement  
for automatic doffing upgrade

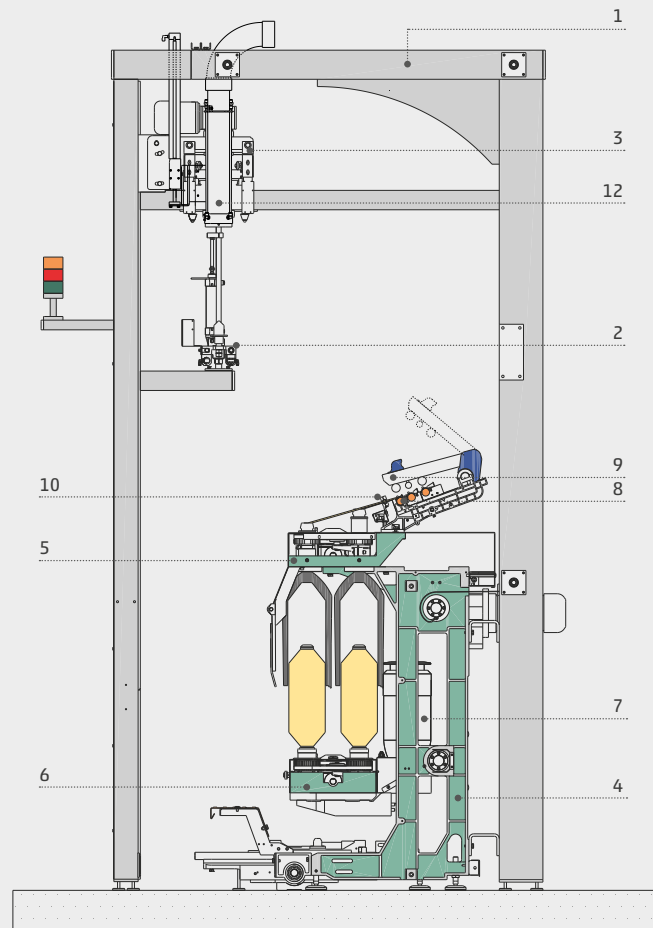

### MACHINE DESCRIPTION - CAPTION

- 1 Supports and doffing columns
- 2 Exchanger
- 3 Doffer rail
- 4 Intermediate leg
- 5 Flyer rail
- 6 Bobbin rail
- 7 Bobbins motor
- 8 Cylinder
- 9 Pressure arm
- 10 Sensors for roving breakages
- 11 Suction ducts if installed
- 12 IBC

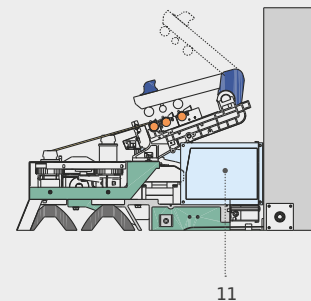

# FT6E & FT7E DRIVES SYSTEM

## Perfect synchronization of all working organs

The updated FT6E and FT7E roving frames draw on the most advanced and reliable electronics in order to perfectly synchronize all the motors driving the working organs (spindles, flyers, bobbin rail and drafting unit).

Mechanical transmission is, therefore, reduced and this grants the following benefits:

- High speed and high quality roving thanks to the elimination of uncontrolled vibrations.
- Low energy consumption thanks to the reduction of mechanical friction.
- High reliability because of the fewer components and the reduced mechanical wear.
- High flexibility because the machine can be easily set electronically through the touch screen interface.

### Mechanical features

The spindles and the flyers drives of the FT6E roving frame include:

- IE3 motors to drive the spindles. One every 32 spindles.
- 1 motor for the flyers drive. 7.5 Kw up to 160 spindles; 11 Kw over 160 spindles.

The spindles and the flyers drives of the FT7E roving frame include:

- IE3 motors to drive the spindles. One every 24 spindles.
- 1 motor for the flyers drive. 7.5 Kw up to 144 spindles; 11 Kw over 144 spindles.

This configuration allows to:

- Reduce machine power consumption.
- Obtain a higher efficiency of the transmission system.
- Reduce noise.
- Reduce maintenance.

### KEY POINTS

- REDUCED POWER CONSUMPTION
- REDUCED VIBRATIONS AND FRICTION
- LOWER MAINTENANCE
- LOW NOISE

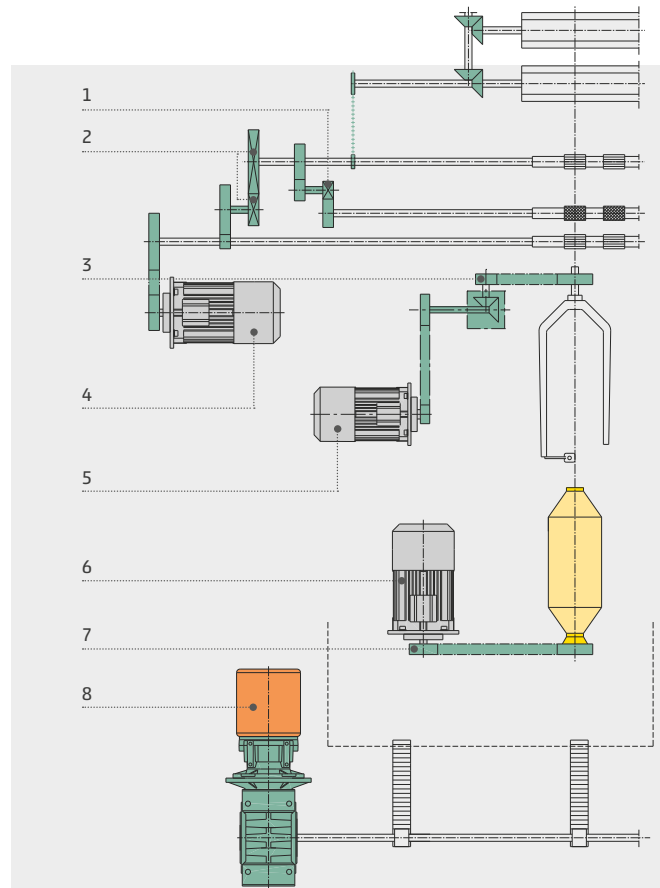

MACHINE DESCRIPTION - CAPTION

- |   |                           |   |                       |
|---|---------------------------|---|-----------------------|
| 1 | Break draft               | 5 | Flyers motor          |
| 2 | Total draft gears         | 6 | Spindles motor        |
| 3 | Timing belt               | 7 | Timing belt           |
| 4 | Motor for drafting system | 8 | Motor for bobbin rail |





# FT6E & FT7E DRAFTING SYSTEM

## Perfect control and uniform draft

The drafting system of the FT6E and FT7E roving frames ensures a constant load for every spinning position for a perfect control and uniform draft of the slivers. It is available in different configurations in order to effectively address any market request:

- Three-over-three or four-over-four
- 32 mm or 27 mm cylinder diameters
- Pneumatic or mechanical pressure arms
- Rubber scraper or revolving felt belt for drafting rollers cleaner
- Rubber fins or revolving felt belt for top roller cleaner
- Auxiliary drafting drive

### Cylinder cleaner

For the drafting cylinders of its FT6E and FT7E roving frames Marzoli offers two options: hard rubber scrapers placed beneath the cylinders, revolving self-cleaning felt belts. Both solutions ensure high cleaning efficiency at each spinning position, guaranteeing top effectiveness of the drafting system and preventing any overlap of the roving on the cylinders.

### Top roller cleaners

For the top rollers Marzoli offers two options: cleaners with rubber fins (*Figure A*), revolving self-cleaning felt belts (*Figure B*). Both solutions guarantee an effective cleaning of the top rollers assuring their effectiveness during draft.

### Auxiliary drafting drive

Marzoli offers an auxiliary drafting drive to avoid any vibration and reduce torque and torsion of the drafting rollers on extra long roving frames or when spinning man made fibers that are hard to draft. This driving box is located in the tail stock.

### KEY POINTS

- PERFECT DRAFT OF THE SLIVERS
- SEVERAL OPTIONS FOR THE DRAFTING SYSTEM
- HIGH CLEANING EFFECTIVENESS FOR CYLINDERS & TOP ROLLERS



Figure A



Figure B

# INNOVATIONS ON COMPONENTS

## Smart solutions to boost efficiency & productivity

Marzoli has always dedicated great attention to every detail of its machines and, from the meticulous design of each component and the drive towards continuous innovation, some simple but effective solutions to boost efficiency and productivity have been found.

### Automatic piecing-up after doffing

Thanks to a velcro strip located on the top of the tubes Marzoli roving frames can perform an automatic piecing-up of the roving when restarting production after doffing.

### Tube diameter of 48 mm

Possibility to use tubes with diameters of 48 mm, instead of standard tubes with diameters of 53.5 mm. This solution allows to increase the amount of roving on the tube and therefore reduces the number of doffing cycles, boosts productivity of the roving frame and reduces the bobbin changes at the spinning frame.

### Hexagonal aluminum creel rollers & sensors to detect sliver breakages

The feeding creel can be equipped with four, five or six rows of cans of 20" or 24" of diameter. The positively driven creel, made of four, five or six rollers with hexagonal shape, prevents false drafts of the slivers. A set of photocell sensors immediately detects any possible breakage of the slivers and promptly stops the machine.

The FT6E and FT7E roving frames are equipped with a settable creel. The aluminum rollers position can be longitudinally set while the support can be vertically adjusted in order to change the height of the creel and facilitate the access to the slivers feeding area.

### KEY POINTS

- AUTOMATIC PIECING-UP OF THE ROVING AFTER DOFFING
- THINNER TUBES FOR HIGHER BOBBIN CAPACITY
- HEXAGONAL CREEL ROLLERS TO PREVENT SLIVER FALSE DRAFTS
- IMMEDIATE STOP OF THE MACHINE IN CASE OF SLIVER/ROVING BREAKAGE

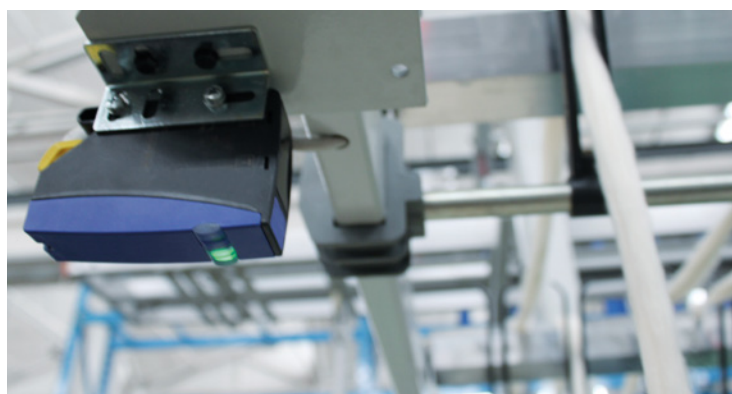
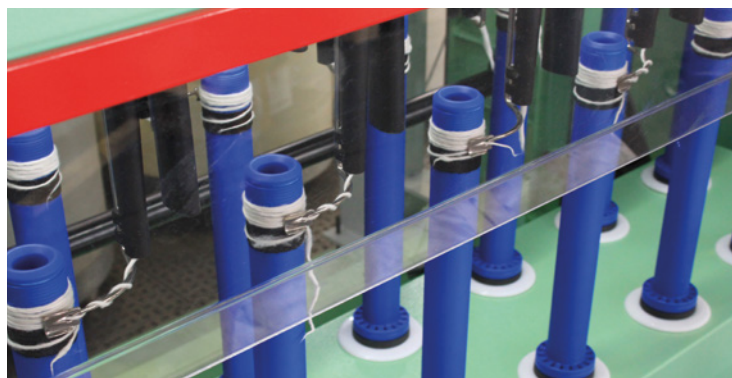



### Individual sensors to detect any roving breakage (option)

Marzoli roving frames can be equipped with special sensors, one for each spinning position, that allow to immediately identify any roving breakage and to promptly stop the machine. These sensors overturn the way the photocell on the standard machine works: the photocell stops the machine if it detects the breakage of the roving; the individual sensor stops the machine if it does not detect the presence of the roving.

This discloses the following advantages:

- In case of overlap of any roving, the individual sensors guarantee the machine stop, avoiding waste of roving and damages to the drafting cylinders.
- In case dust passed in front of the sensors, the machine would continue to work, whereas with the photocell the machine would stop.
- Suction is no longer required. In order to let the photocell detect the broken roving, suction systems are needed to guide the roving in front of the photocell. Thanks to the individual sensors Marzoli roving frames can work without suction, allowing the client to save up to 4 kWh.

These sensors allow to calculate the total number of roving breakages per spindle during a formation cycle or a preset period of time (e.g. a day, a week, etc.). This allows the client to immediately identify malfunctions on particular spindles and undertake well-aimed maintenance operations in order to boost productivity with the minimum machine downtime.

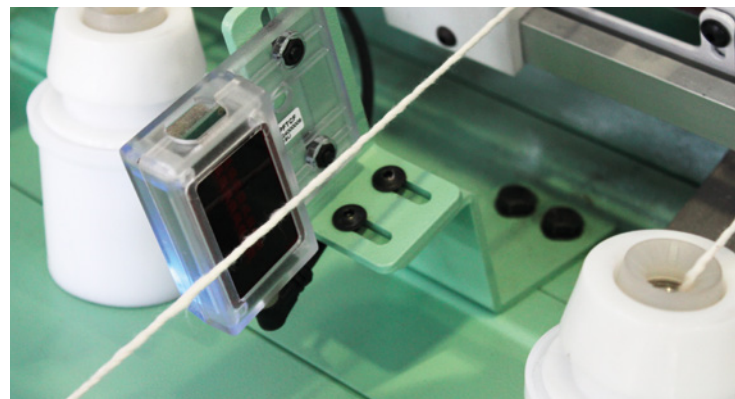

### Integrated sensor for roving tension control

Marzoli integrated sensors for roving tension constantly monitor the fluctuations of the roving in order to evaluate its tension. If the device detects an average tension outside the preset parameters, it adjusts the speed of the spindles in order to bring the value back inside the desired range.

## USER-FRIENDLY INTERFACE

The FT6E and FT7E roving frames are managed by a modern PC microprocessor: all the production data and working parameters are controlled and saved during the production cycle.

The multi-language touch screen is user-friendly and permits a simple use with clear diagrams, detailed monitoring pages and step by step troubleshooting procedures.

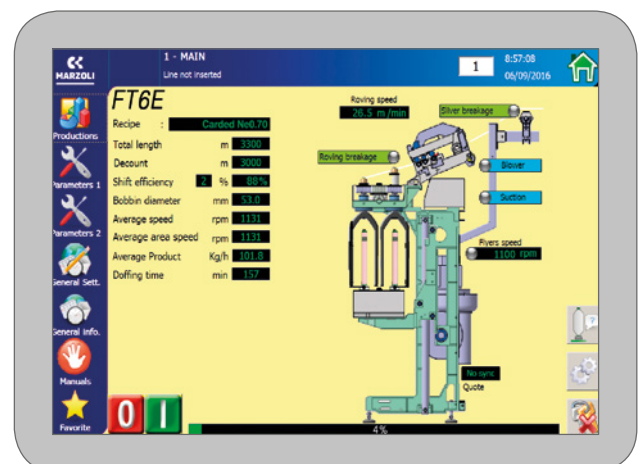

# FT6E&FT7E AUTOMATION

## Three options for doffing

### Semiautomatic doffing

Marzoli roving frames with semiautomatic doffing represent an outstandingly ergonomic machine. The description of the doffing cycle will help understand why:

- End of bobbin build up: the roving frame automatically stops after having reached the preset length
- The bobbin rail lowers and tilts out to allow an easier collection with no poor handling of the full bobbins
- The full bobbins are collected and the empty tubes are taken from the parking area and placed on the spindles.
- The bobbin rail tilts back and the machine restarts automatically.

### Automatic doffing

The highest degree of automation with the consequent benefits in terms of labor savings and quality of roving are achievable with the fully-automatic version of Marzoli roving frame. Hereafter the description of the doffing cycle:

- End of bobbin build up: the roving frame automatically stops after having reached the preset length. A coil at the top or at the bottom of the bobbins is done to prevent unwinding during transportation to the spinning frames.
- The bobbin rail lowers and slides out horizontally while the doffer rail with empty tubes lowers.
- Full bobbins are collected, the doffer rail goes up, moves one position forward, lowers again, leaves the empty tubes on the spindles and goes all the way up.
- The bobbin rail moves back to its working position and the roving frame restarts automatically.

### KEY POINTS

- ERGONOMIC SEMIAUTOMATIC DOFFING
- FULL AUTOMATIC DOFFING IN LESS THAN 3 MINUTES
- PRE-ARRANGEMENT FOR AUTOMATIC-DOFFING UPGRADE



### Pre-arrangement for automatic-doffing upgrade

With the release of the FT6E and FT7E Marzoli offers also a third option: the roving frame with the pre-arrangement for automatic-doffing upgrade. During doffing the bobbin rail lowers and slides out horizontally, just like the fully-automatic model. Besides permitting an easy collection of the full bobbins, this solution allows an easy and cost efficient upgrade the machine to the fully-automatic version.

## MARZOLI TRANSPORT SYSTEMS

In order to ensure the highest efficiency level in internal logistics Marzoli has launched its own-branded bobbin transport systems:

- The MTR – Marzoli Random Creeling Solution: the bobbins are carried by a closed circuit overhead chain along the aisles between the spinning frames.
- The MTT – Marzoli Block Creeling Solution: the full roving bobbins are brought to the reserve row located on both sides of the spinning frame or directly inside the creel by trolley trains (one train per creel row).

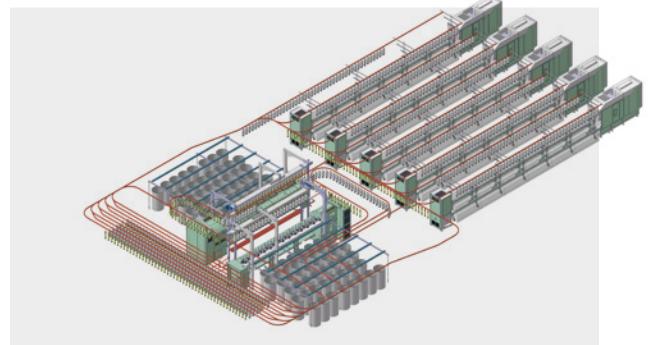
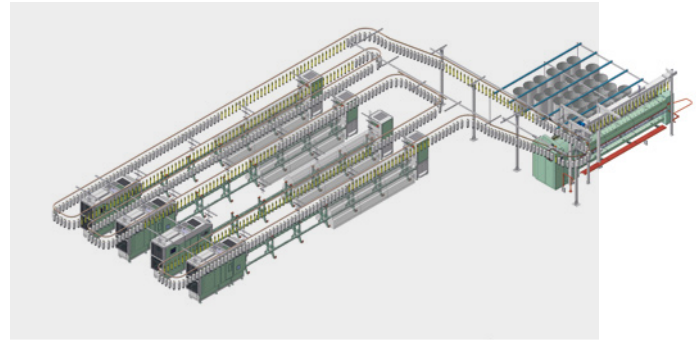

### **MARZOLI IBC**

Bobbin stripper integrated on the exchanger, the IBC gives the spinner the following benefits:

- lower investment and maintenance costs: a separated bobbin stripper is no longer necessary
- Reduced cleaning time (< 10 s for 2 layers on the tube) and fewer stops of the chain to boost the efficiency of the entire spinning section.
- Less strain on the tubes holders as each tube is taken only once for both cleaning and exchanging operations



### **MARZOLI MRE**

MRE (Marzoli patent) is a new solution to boost efficiency on the operations of exchanging and cleaning of empty tubes. With Marzoli MRE two full bobbins and two tubes are taken simultaneously from the doffer rail and the transport rail. After an intermediate step in which the tubes are cleaned by two integrated IBCs, Marzoli MRE places the empty tubes on the doffer rail and the full bobbins on the transport rail. With this system the process can be done two times faster than single exchangers

(cleaning and exchanging of 240 bobbins /hour), an aspect that can underpin higher efficiency rates on long roving frames and/or when coarse counts are produced. Marzoli MRE can be installed on roving frames of either 110mm or 130mm and exchange bobbins with transport systems with any of the main available gauges.

It can be installed on either the head or the tail stock to save on transport systems and IBC suction ducts.



**TECHNICAL DATA**

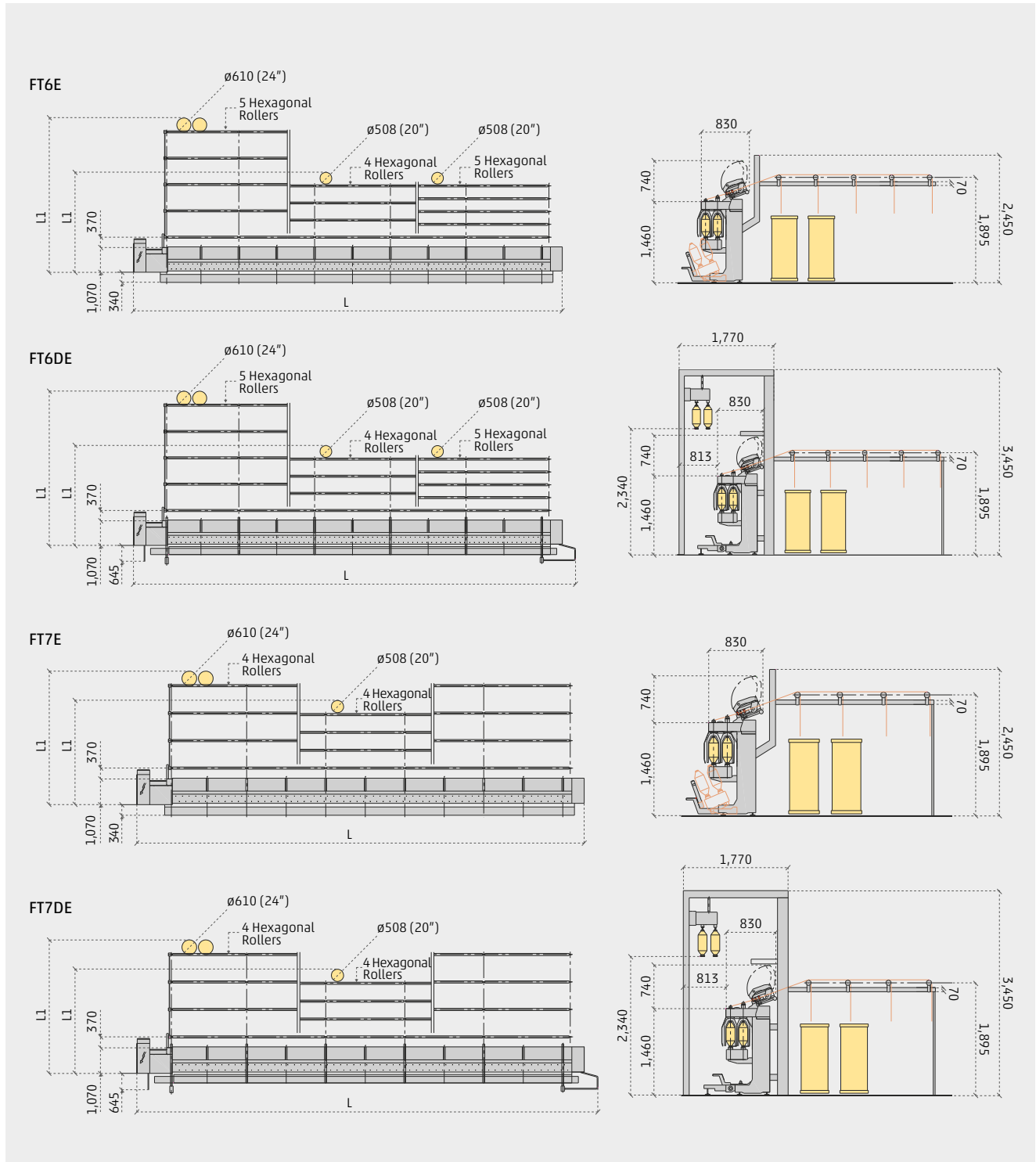

Roving Frame FT6E / FT7E		FT6E	FT6DE	FT7E	FT7DE
Material	Cotton, man-made fibers and blends, up to 60 mm	110 mm	110 mm	130 mm	130 mm
Roving count range	Ne 0.40 - 3.5 / Nm 0.7 - 5.9 / Tex 170 - 1,470	16	16	12	12
Roving twist range	Tw/\"	240	240	192	192
Draft	4 - 20	6\"	6\"	7\"	7\"
		no	yes	no	yes

Roving Frame FT6E / FT7E	
Flyer speed	(mechanical) up to 1,500 rpm
Delivery speed	up to 50 m/min

FT6E/FT6DE		
	SEMI-AUTOMATIC DOFFING	AUTOMATIC DOFFING
Cylinders drive motor	4 kW	4 kW
Bobbin rail drive motor	3.77 kW	3.77 kW
Bobbin rail outward motion drive motor	//	0.37 kW
Doffer rail drive motor	//	1.85 kW
Belt drive motor	//	0.25 kW
Spindles drive motors	3 kW every 32	
Flyers drive motor	7.5 kW up to 160 spindles; 11 kW over 160 spindles	
Suction drive motor (OPTIONAL)	+ 4 Kw	

FT7E/FT7DE		
	SEMI-AUTOMATIC DOFFING	AUTOMATIC DOFFING
Cylinders drive motor	4 kW	4 kW
Bobbin rail drive motor	3.77 kW	3.77 kW
Bobbin rail outward motion drive motor	//	0.37 kW
Doffer rail drive motor	//	1.85 kW
Belt drive motor	//	0.25 kW
Spindles drive motors	3 kW every 24	
Flyers drive motor	7.5 kW up to 144 spindles; 11 kW over 144 spindles	
Suction drive motor (OPTIONAL)	+ 4 Kw	

FT6E Total length = 1565+ No.spindles*110mm+TS		FT7E Total length = 1565+ No.spindles*130mm+TS	
	TS		TS
Semiautomatic doffing <b>without</b> suction	395	Semiautomatic doffing <b>without</b> suction	345
Semiautomatic doffing <b>with</b> suction	625	Semiautomatic doffing <b>with</b> suction	575
Automatic doffing	1,170	Automatic doffing	1,120

Can Diameter (inches)	No. Rollers	Rows of cans	L1 (mm)	Can Diameter (inches)	No. Rollers	Rows of cans	L1 (mm)
20"	4	5	4,670	20"	4	4	4,150
	5				5		
	6				6		
24"	4	6	5,820	24"	4	5	5,310
	5				5		
	6				6		

## OUTSTANDING ENERGETIC PERFORMANCES

Marzoli aims at reducing the environmental impact of its processes and products during all phases of the product life cycle, starting from production to machinery use within the client's plant. Marzoli FT6E and FT7E roving frames fully embrace this business philosophy and deliver outstanding energetic performances throughout their service life.

The FT6E and FT7E, thanks to their innovative technology, do not need suction. This, along with the high efficiency motors and an overall design intended to minimize friction, entails an energy saving of over 4 kWh with a reduction of the kW/kg ratio of over 10%.

### REDUCTION IN POWER CONSUMPTION IN THE LAST 20 YEARS NEO.80

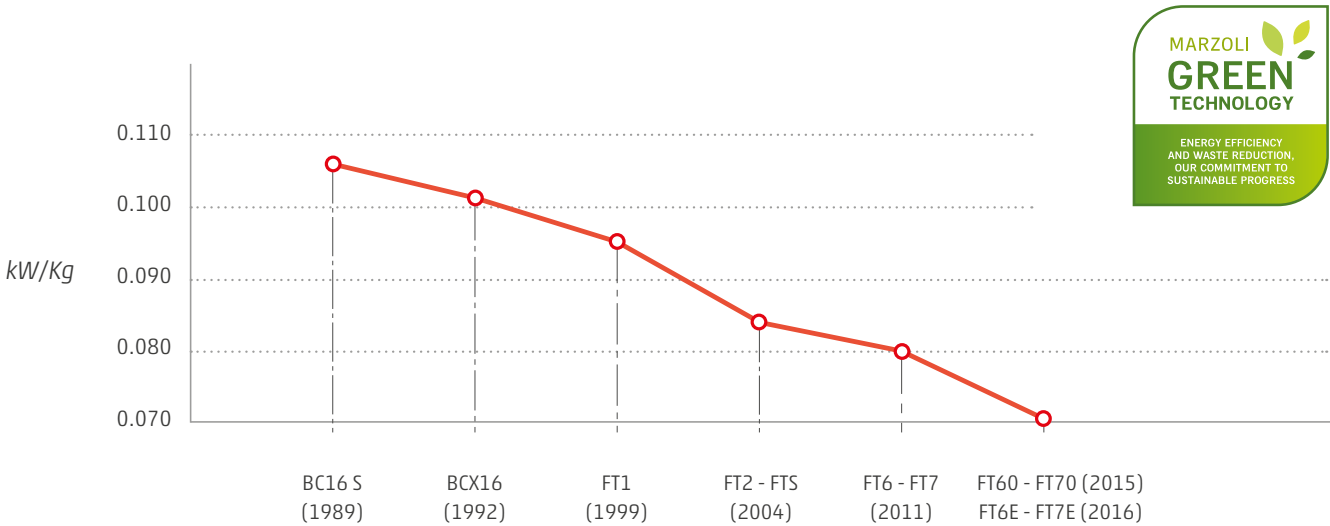

FT6E - FT7E power consumption				
Roving count Ne	0.5	0.8	1.2	1.5
Speed Rpm	1,050	1,200	1,220	1,250
Production gr/sp/h	1,900	1,210	640	460
kW/kg	0.035	0.070	0.128	0.187

The kW/kg values may vary according to the operational conditions of the machines.



# SOFTWARE PLATFORMS

## END2END PRODUCTION MANAGEMENT PLATFORM: YARNET

YarNet is Marzoli production management software. It enables the monitoring of production levels, efficiency rates and downtime for both individual machines and the entire spinning mill. Comparisons between machines on selected periods of time are made very simple so that improvement opportunities can be easily identified. YarNet enables the operator to edit production recipes, downloading and uploading them between any machine and their computer. He can also export them in Excel format to share with colleagues as necessary. YarNet gathers and analyses data about production and energy consumption, giving a visual representation of the tradeoffs (kW/kg).

## MRM

MRM is Marzoli software to continuously monitor the operating conditions of textile machines. It can identify developing malfunctions before a fault occurs and highlight improvement opportunities on efficiency rates and energy consumption levels. Data about temperature, power consumption, speed and vibration are collected from PLCs (programmable logic controllers) and sensors installed on each machine. The software verifies the monitored parameters are within the nominal operating ranges; it can even adjust for room temperature variations to ensure continuous optimisation. If any parameter is out of tolerance, an automatic email alert is sent to the customer. The customer can also access the dedicated online portal to see information for predictive maintenance and of the overall efficiency of the plant. Through dedicated modules (Optimisation Tools) it is possible to optimise the performance of every machine, in particular on energy consumption and levels of efficiency. If required, Marzoli's customer service team can access the data to diagnose actual and developing problems and recommend appropriate actions.

## KEY POINTS

- EASY & FAST CONTROL OF EVERY STAGE OF THE SPINNING PROCESS
- IMPROVED SPEED OF RESPONSE IN PRODUCTION OPERATIONS
- EASY MANAGEMENT OF PRODUCTION RECIPES
- SUPERIOR, EASIER AND FASTER MAINTENANCE

## YARNET

Marzoli Production Management

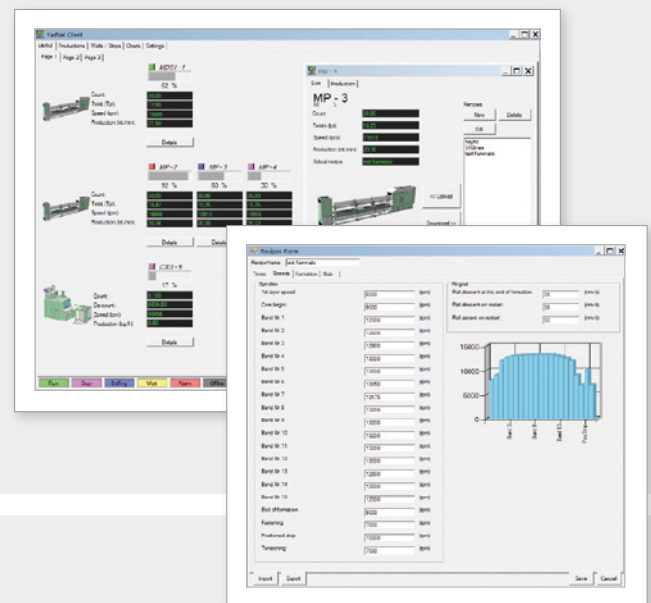

## MRM Marzoli Remote Maintenance

IoT Platform by Microsoft®

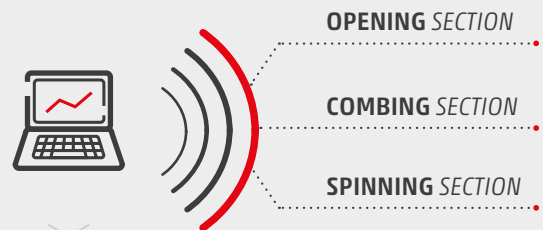

## BENEFITS

- Higher productivity
- No machines unplanned downtimes
- Prevention from major machine failures
- Longer plant lifespan
- Higher efficiency
- Complete reliability
- Trouble free spinning experience
- Better maintenance planning

MARZOLI  
INTERNATIONAL, INC.  
USA

MARZOLI MACHINES  
TEXTILE SRL  
Italy

MARZOLI INDIA  
MTMM PVT. LTD.  
India

- Legend**
- Marzoli premises
  - Sales & service network
  - Sales affiliates

**Marzoli Machines Textile S.r.l.**  
Via Sant'Alberto, 10  
25036 Palazzolo sull'Oglio (BS)  
Italy  
Tel. +39 030 73091  
sales@marzoli.it

**Marzoli International, Inc.**  
100 Corporate Dr., Suite M  
Spartanburg, SC 29303  
U.S.A.  
Tel. +1 864 599 7100  
Fax +1 864 599 7111  
sales@marzoli.com

**Marzoli India  
MTMM Pvt. Ltd.**  
Shed No 6, Bangalore Main Road  
SIDCO Industrial Estate  
Hosur - 635 126  
Krishnagiri District, Tamil Nadu  
India  
Tel +91 4344 400111

  
**MARZOLI**  
Textile Engineering

A Camozzi Group Company  
[www.marzoli.com](http://www.marzoli.com)