



Testa
group



**Inspection
Machines**

SINCE 1969

**Our solutions
for traditional
fabric inspection.**

**Versatile,
precise and resistant
inspection machines**

Our solutions for traditional fabric inspection include essential models, for a greater degree of dexterity in operations, and automated models, which require an operator only to check the fabric. All models own specific technical features depending on the fabric to be processed. They are modular and can be integrated with optionals on request. They are equipped with certified metric counting devices, a simple and functional operator interface and remote control for assistance in real time.

**Management
of fabric defects
control**

Our inspection machines are equipped with a software for the acquisition of the data of the defects present in the individual rolls, which are communicated directly to the customer's ERP system. The software allows the production of detailed reports showing the characteristics of each roll, ensuring an optimal level of traceability of production data.

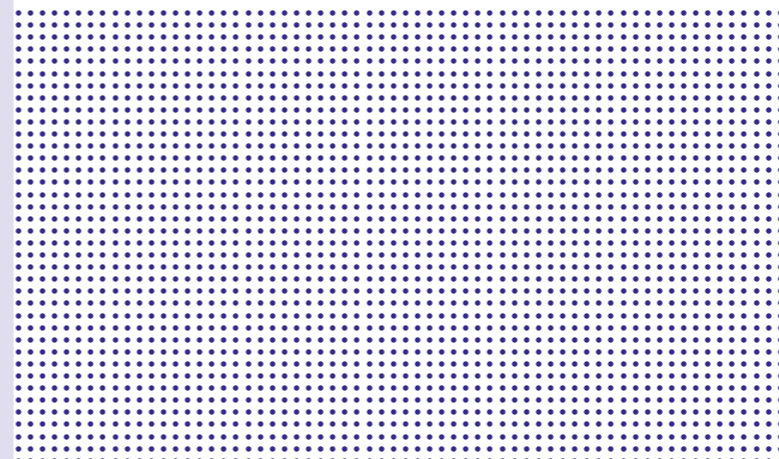
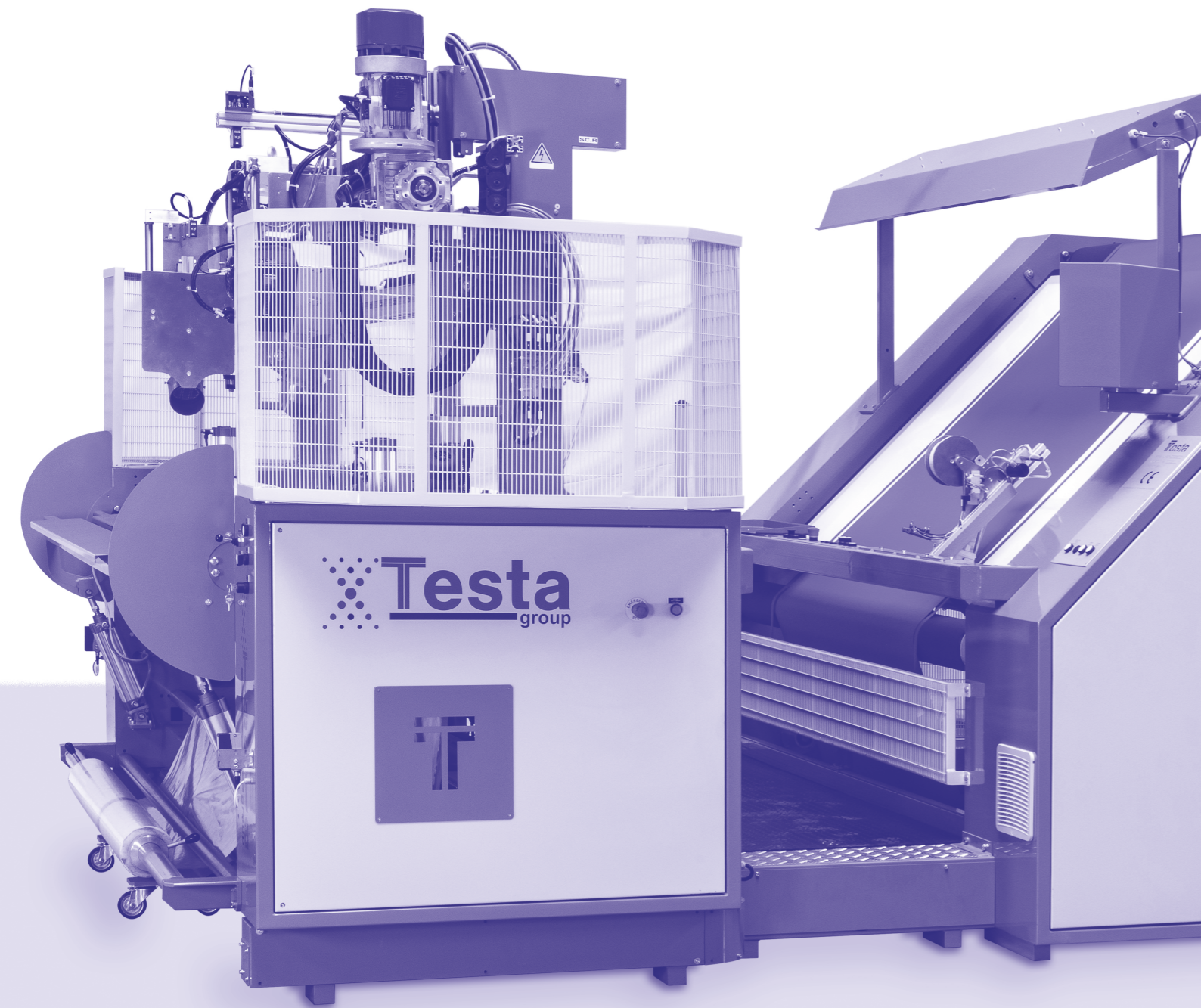

Fabric doubling triangle

This very important device is able to double the fabric in the same machine used to inspect, roll and, possibly, pack rolls. The triangle, vertically assembled, is placed at the inlet of the machine: that allows to save much space. It can align the fabric by means of an electronic synchronization system working through photocells, feeler pins and double alignment.

The main technical features of this machine allow one to:

- inspect the fabric in its maximum width and to wind it in open width
- inspect the fabric in its maximum width and to wind it doubled.

The fabric doubling device can be applied in the different machine models produced by Testa Group.

Exclusive system that allows to pass from the fabric lengthwise winding, to the fabric doubled winding and vice versa, without having to draw the fabric out of the machine

This exclusive device allows a varied use of the plant, even for the customers dealing with a mixed production of lengthwise and doubled fabric.

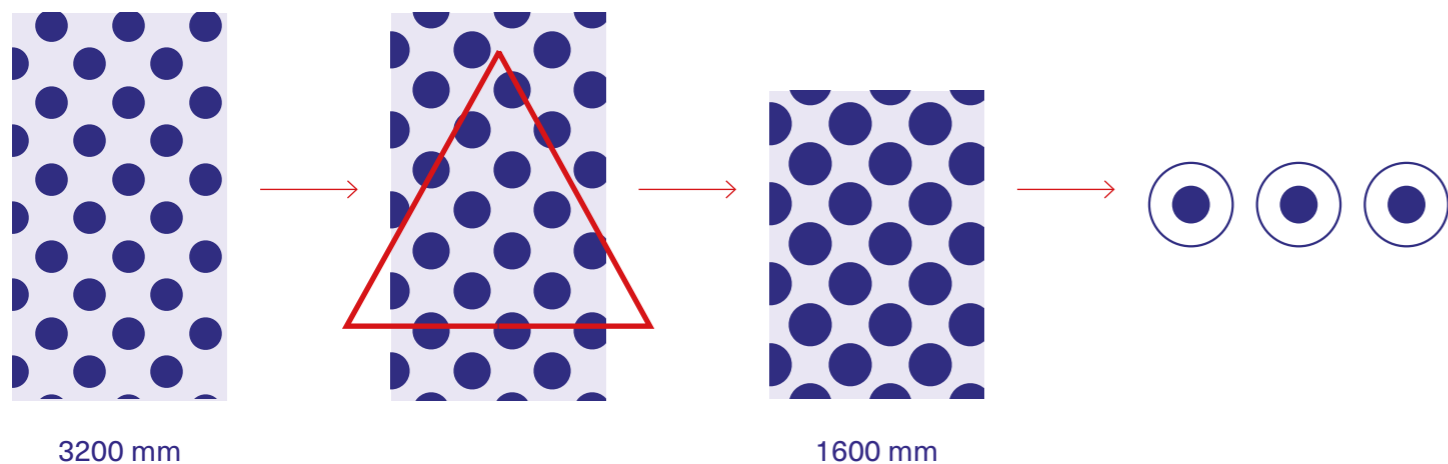

Schematization of roll-making at pre-set metres with first-rate rolls

1. Meters are set in the PC in order to have all the rolls of the same length. Example: mt 50.
2. At the beginning-end of each fabric fault, the operator presses the button of fault beginning-end. The defective fabric meters are automatically cut and discarded by the machine. This operation must be carried out whenever one wants to discard defective fabric.
3. Defective fabric cut-discard
4. First-rate fabric joint by means of overlapping laps or laps joined by cutting-sewing machine or thermo welding.
5. Carrying on of first-rate fabric rolling until the set meters have been reached.
6. All the production will consist of first-rate rolls with pre-set length.

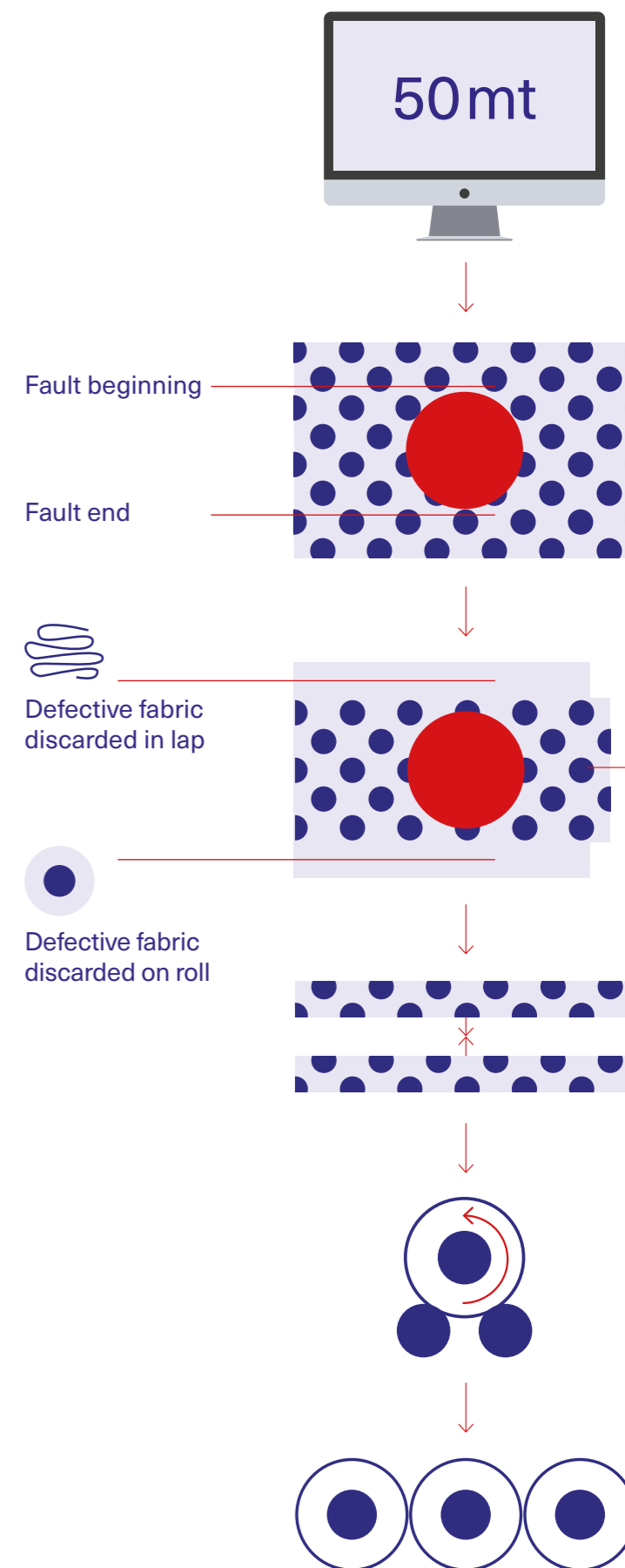

Mod. 109

Compact and versatile model that allows the inspection of any type of fabric and the winding of the roll in front of the operator. It can be placed

as an end of line to work online with production machines, it guarantees compliance with the fabric tension and precision in metric counting.

Types of machine inlets

- Small roll towed or driven in a motorized cradle
- Large towed or driven roll
- Folded fabric
- J- Box

Functionality

- Adjustable fabric tension
- Adjustable roll hardness
- Perfect alignment of the fabric by means of a mobile trolley
- Certified electronic meter counter
- Cross cut at programmed meters or at seam



6

MOD. 109

DRIVEN CYLINDER

IDLER ROLL

SCROLL CYLINDER

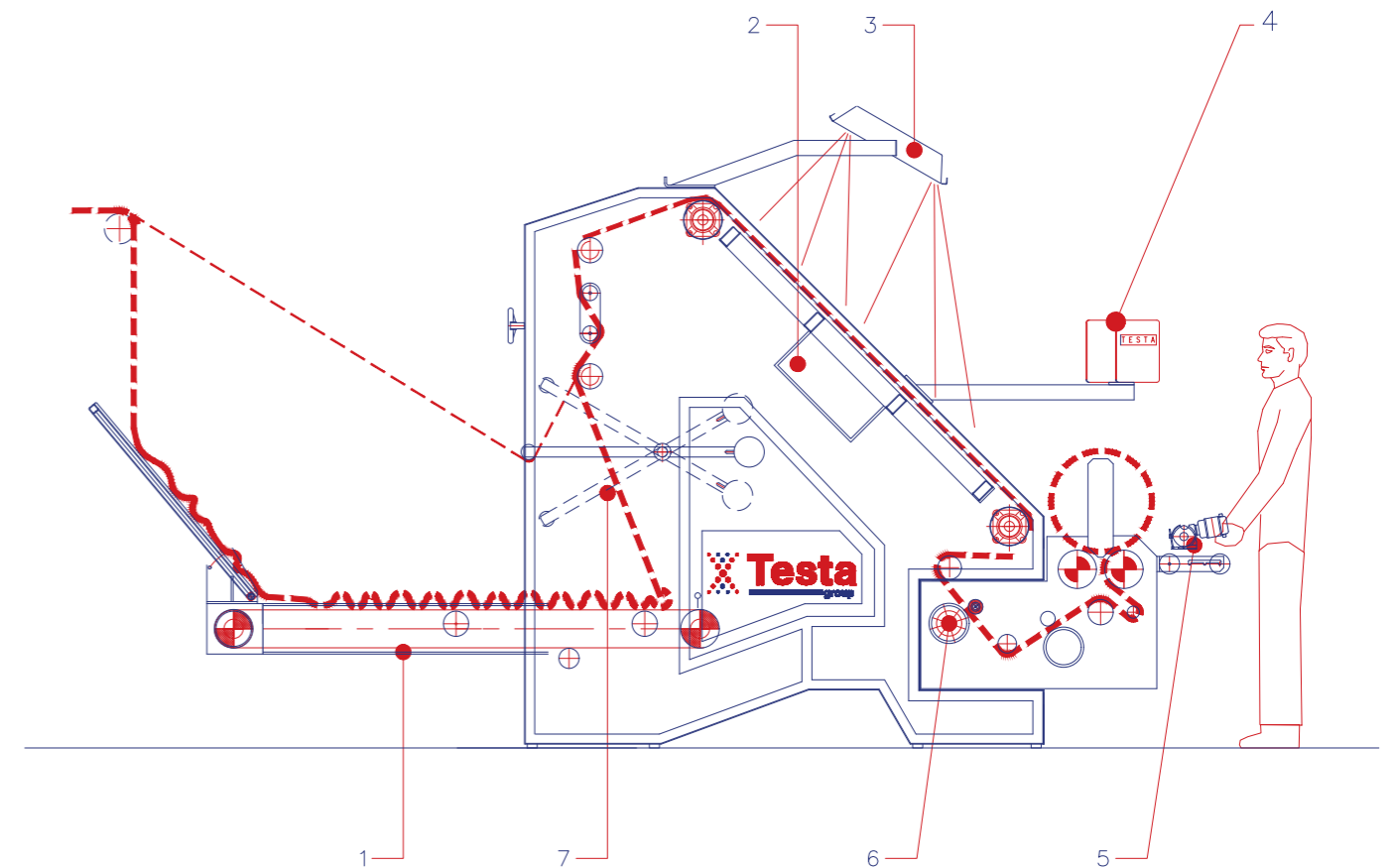

1. input by conveyor
2. internal light
3. external light
4. touchscreen
5. manual cutting
6. meter counter
7. compensator

7

Mod. 111

Simple and versatile model that allows the inspection of any type of fabric and the winding of the roll behind the operator. Ideal for the knit and stretch fabrics market, it respects the tension of the fabric and guarantees precision in metric counting.

Types of machine inlets

- Small roll towed or driven in a motorized cradle
- Large towed or driven roll
- Folded fabric
- J- Box

Functionality

- Adjustable fabric tension
- Adjustable roll hardness
- Perfect alignment of the fabric by means of a mobile trolley
- Certified electronic meter counter
- Cross cut at programmed meters or at seam



MOD. 111

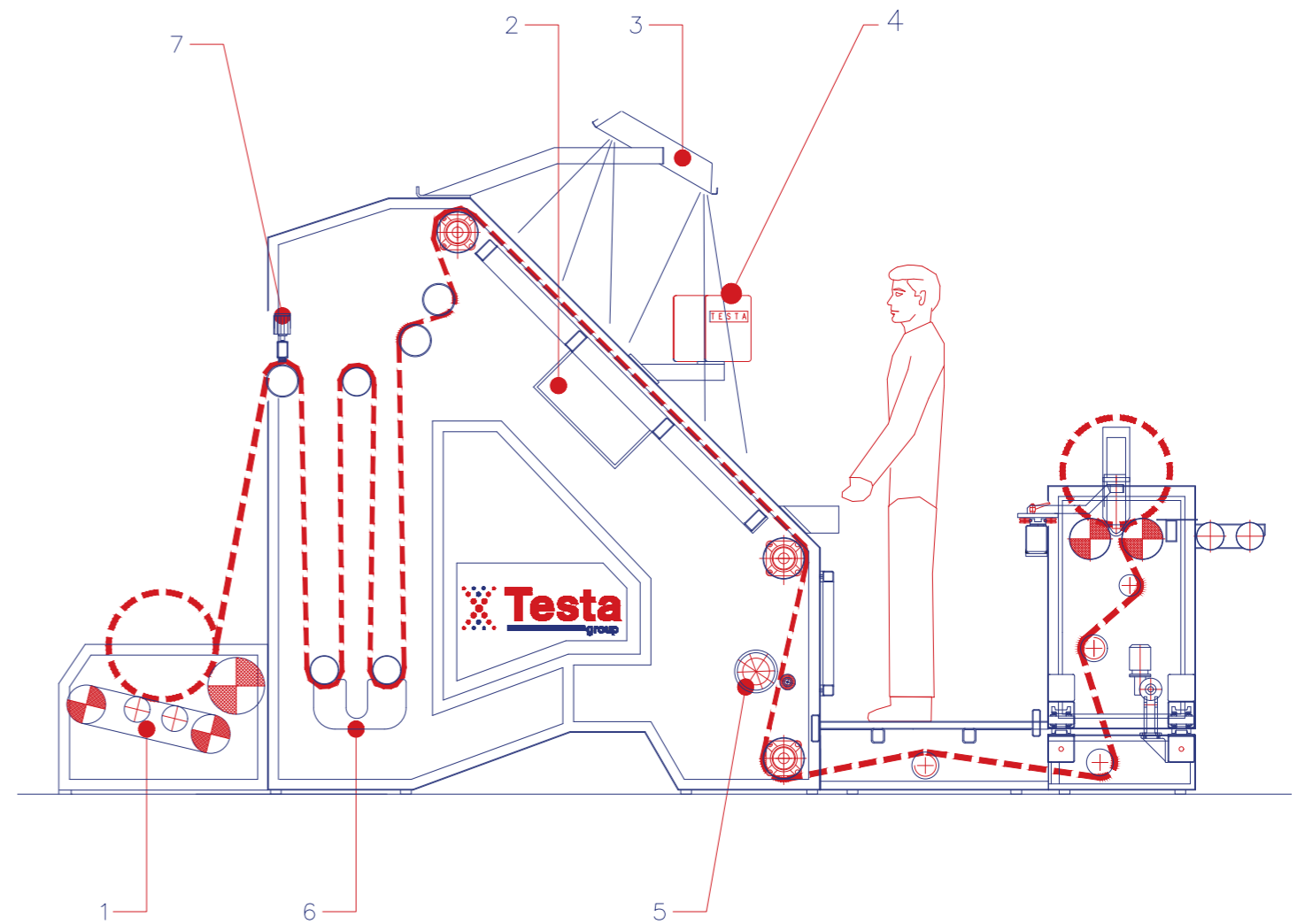
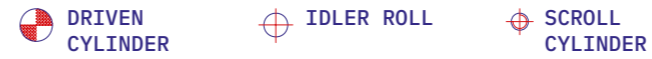

- 1. input by small driven roll
- 2. internal light
- 3. external light
- 4. touchscreen

- 5. meter counter
- 6. compensator
- 7. stop fabric device

Mod. 111 Eureka

First introduced to the market by Testa in 1992, it includes semi-automatic or fully automated models that integrate inspection, winding, cutting and packing of fabric rolls. They allow work cycles

such as the rejection of the defective fabric, the automatic resumption of the fabric after cutting, the packaging of the rolls with plastic film and the final labeling procedures.

Dedicated to traditional textiles and technical articles.

Types of machine inlets

- Small roll towed or driven in a motorized cradle
- Large towed or driven roll
- Folded fabric
- J- Box
- Accumulation driven belt

Optional

- Inspection table inclination: 30°, 45°, 60° or adjustable as needed
- Internal table light, antistatic bar, defect markers, sewing reader, width reader, semi-automatic or automatic hopper
- Automatic restart of the new roll with hot melt or without adhesive support
- Zig-Zag device
- Inner scale
- Double automatic feeding of polythene based on the width of the fabric
- Automatic internal or external labeling of the roll (on the body or on the head) or both.
- Sample labeling
- Data exchange with the host in real time

Benefits

- Perfect roll hardness, alignment, fabric measurement
- Variable (non-fixed) cut of the sample and waste
- Possibility of wrapping the second choice on a tube
- Integrated packaging. There is no need to close the roll with adhesive tape
- Perfect packaging, adherent, suitable for exports.
- Saving of plastic film thanks to the precise calculation of the diameter of the rolls
- Space saving compared to the traditional solutions they provide conveyor belts
- Labor saving: Only one operator required for fabric inspection. No operator expected in the absence of inspection
- Energy saving



Eureka 1

It allows fabric cutting at pre-set meters.



Eureka 2

It allows seam cutting/defective fabric in lap cutting. (Point 11 in the layout)

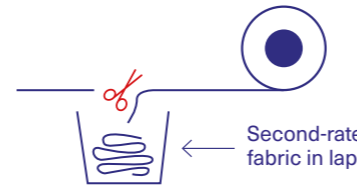

Eureka 3

It allows seam cutting and automatic discard/defective fabric in lap or on roll cutting and discard/sample fabric cutting and discard (hoses). (Points 11 and 12 in the layout)

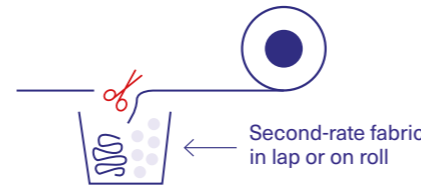

Eureka 4

It allows seam cutting and automatic discard/defective fabric in lap cutting and discard ! sample fabric cutting and discard (hoses). (Point 10 in the layout) Besides, this machine can retake first-rate fabric in automatic mode in order to carry on rolling until the set meters have been reached.

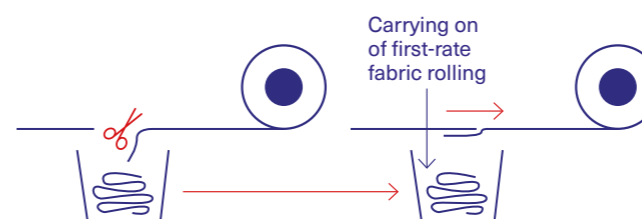

Eureka 5

It allows seam cutting and automatic discard/defective fabric in lap or on roll cutting and discard / sample fabric cutting and discard (hoses).(Points 10 and 11 in the layout) Besides, this machine can retake first-rate fabric in automatic mode in order to carry on rolling until the set meters have been reached.

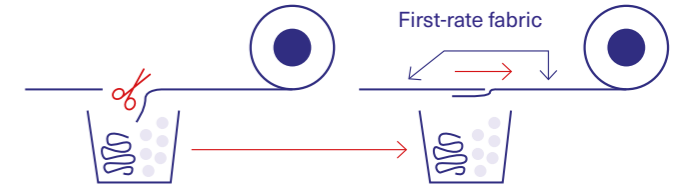

Eureka 6

It allows seam cutting and automatic discard/defective fabric in lap or on roll cutting and discard / sample fabric cutting and discard (hoses).(Points 10 and 11 in the layout) Besides, this machine can retake first-rate fabric in automatic mode in order to carry on rolling until the set meters have been reached. First-rate fabric can also be automatically jointed by automatic sewing machine or by thermo welding. (Point 16 in the layout)

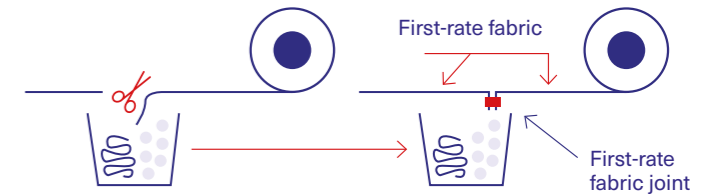

Eureka 7

It allows the automatic retake of first/second-rate fabric, with the winding of several first-rate fabric pieces on the same roll and of several second-rate fabric pieces always on roll. This revolutionary system allows the automatic winding of first/second-rate fabric on roll thanks to a device able to lift the second-rate fabric roll and to park it while the machine is winding first-rate fabric rolls. The various second-rate fabric types are wound on roll without seams or joints, but thanks to the overlapping of fabric ends. The machine is also capable of automatically passing from the first-rate fabric winding to the second-rate one. Besides, it is possible to count the already wound first-rate fabric meters as well as the second-rate fabric ones, whether in roll or in lap. If necessary, the second-rate fabric roll is also weighed, labelled, packed, just like any other roll, by means of operations automatically carried out by the machine itself.

- Second-rate roll parked
- Device for the automatic change for first/second-rate fabric winding
- The first-rate fabric is parked awaiting winding on a roll of the second-rate fabric
- Winding of several second-rate fabric pieces on one roll by overlapping
- Not marketable second-rate fabric
- Winding of the first-rate roll up to the pre-set meters

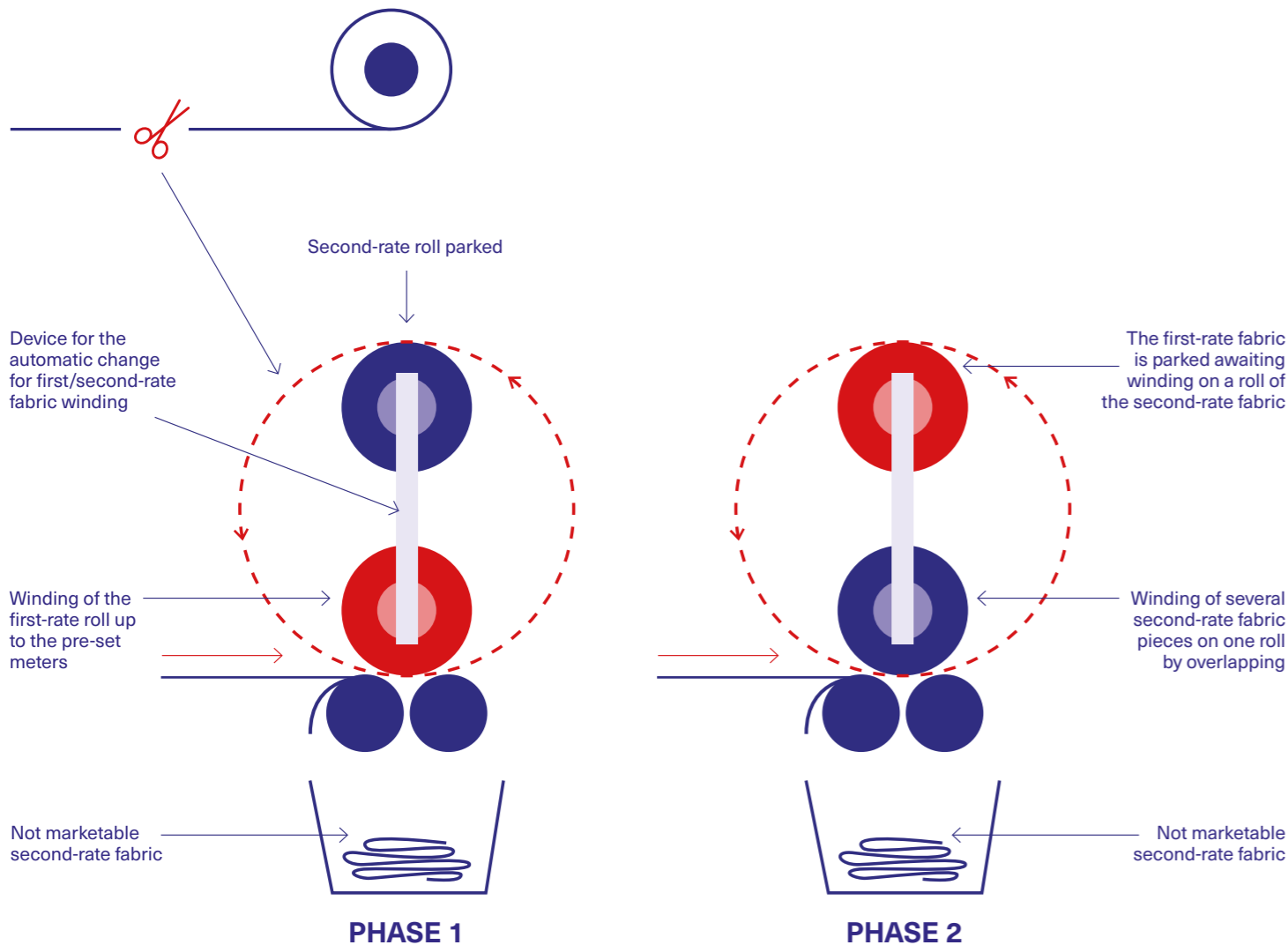

Eureka 8



It allows the automatic retake of first/second-rate fabric, with the winding of several first-rate fabric pieces on the same roll and of several second-rate fabric pieces always on roll. This revolutionary system allows the automatic winding of first/second-rate fabric on roll thanks to a device able to lift the second-rate fabric roll and to park it while the machine is winding first-rate fabric rolls. The various first/ second-rate fabric pieces are wound on roll and automatically joined by means of an automatic seaming device, (cutting-sewing machine or thermal welding system). (Point 15 in the layout) The machine is also capable of automatically passing from the first-rate fabric winding to the second-rate one. Besides, it is possible to count the already wound first-rate fabric meters as well as the second-rate fabric ones, whether in roll or in lap. If necessary, the second-rate fabric roll is also weighed, labelled, packed, just like any other roll,

by means of operations automatically carried out by the machine itself.

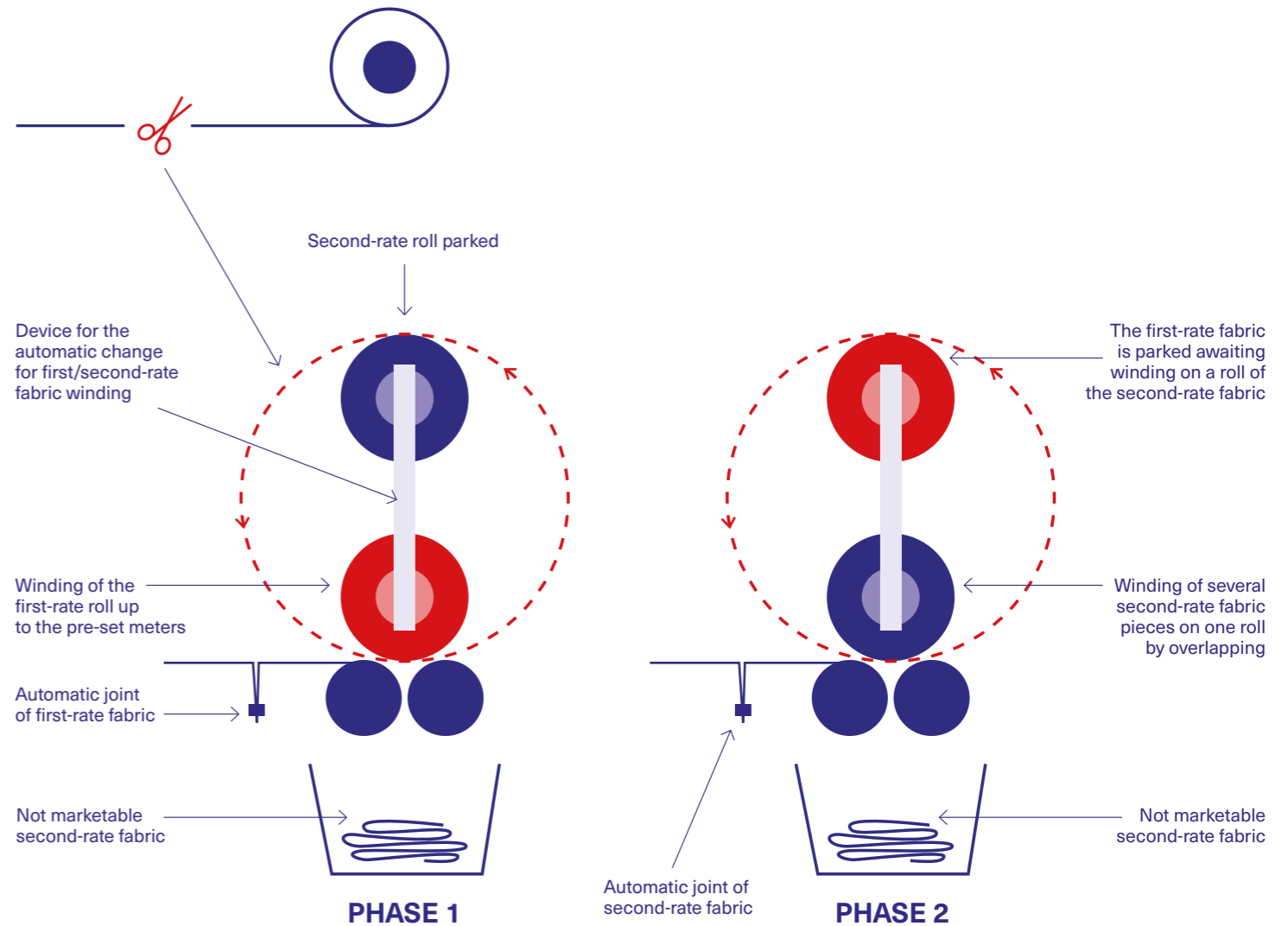
- Second-rate roll parked
- Device for the automatic change for first/second-rate fabric winding
- The first-rate fabric is parked awaiting winding on a roll of the second-rate fabric
- Winding of several second-rate fabric pieces on one roll by overlapping
- Not marketable second-rate fabric
- Automatic joint of second-rate fabric
- Winding of the first-rate roll up to the pre-set meters
- Automatic joint of first-rate fabric



MOD. 111 EUREKA 1,2,3

-  DRIVEN CYLINDER
-  IDLER ROLL
-  SCROLL CYLINDER

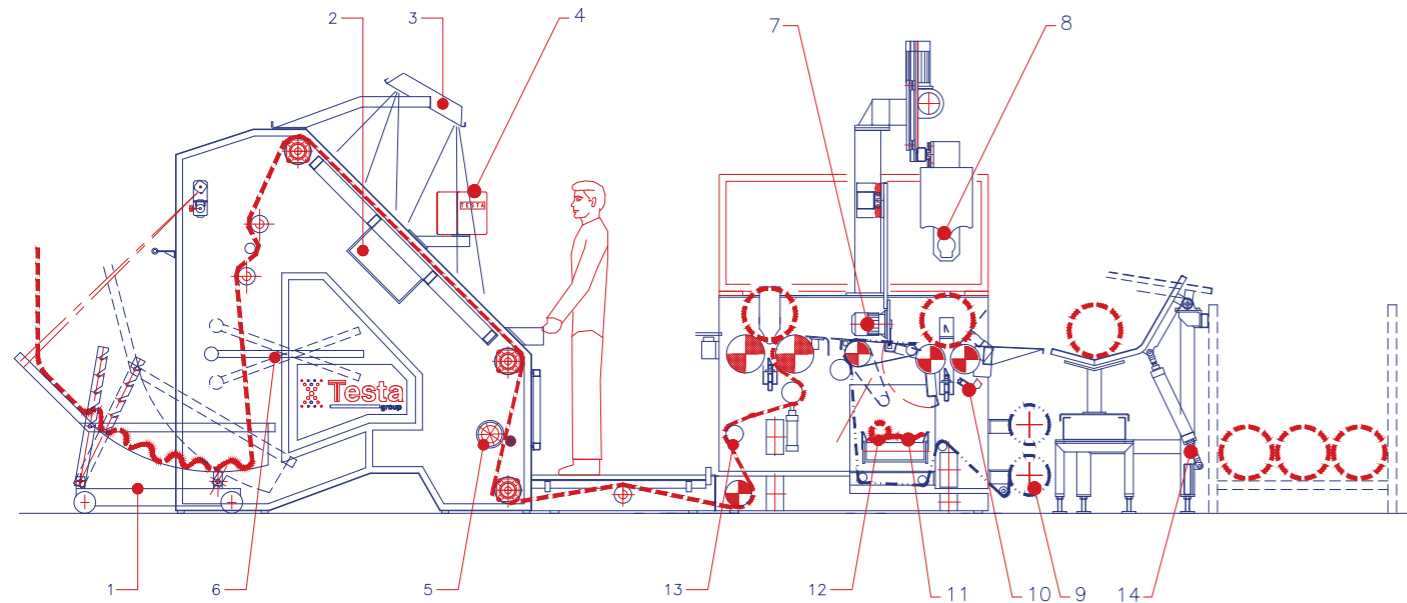

- | | |
|---|--|
| <ul style="list-style-type: none"> 1. input by j-box 2. internal light 3. external light 4. touchscreen panel 5. meter counter 6. compensator 7. automatic cutting | <ul style="list-style-type: none"> 8. lateral closing 9. plastic 10. longitudinal closing 11. rejection in flap 12. rejection on roll 13. zig-zag system 14. tilting device |
|---|--|

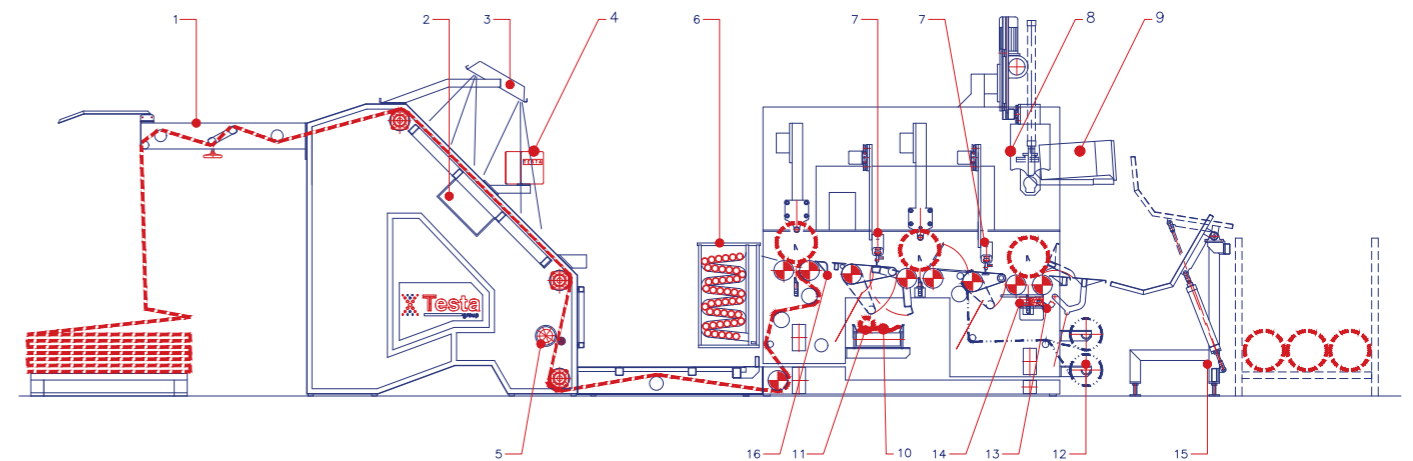

MOD. 111 EUREKA 4,5,6

-  DRIVEN CYLINDER
-  IDLER ROLL
-  SCROLL CYLINDER



- | | |
|---|--|
| <ul style="list-style-type: none"> 1. input by flap 2. internal light 3. external light 4. touchscreen panel 5. meter counter 6. automatic hopper 7. automatic cutting 8. lateral closing | <ul style="list-style-type: none"> 9. labeller 10. rejection in flap 11. rejection on roll 12. plastic 13. longitudinal closing 14. weighing device 15. tilting device 16. cutting-sewing device |
|---|--|

MOD. 111 EUREKA 7,8

 DRIVEN CYLINDER
  IDLER ROLL
  SCROLL CYLINDER

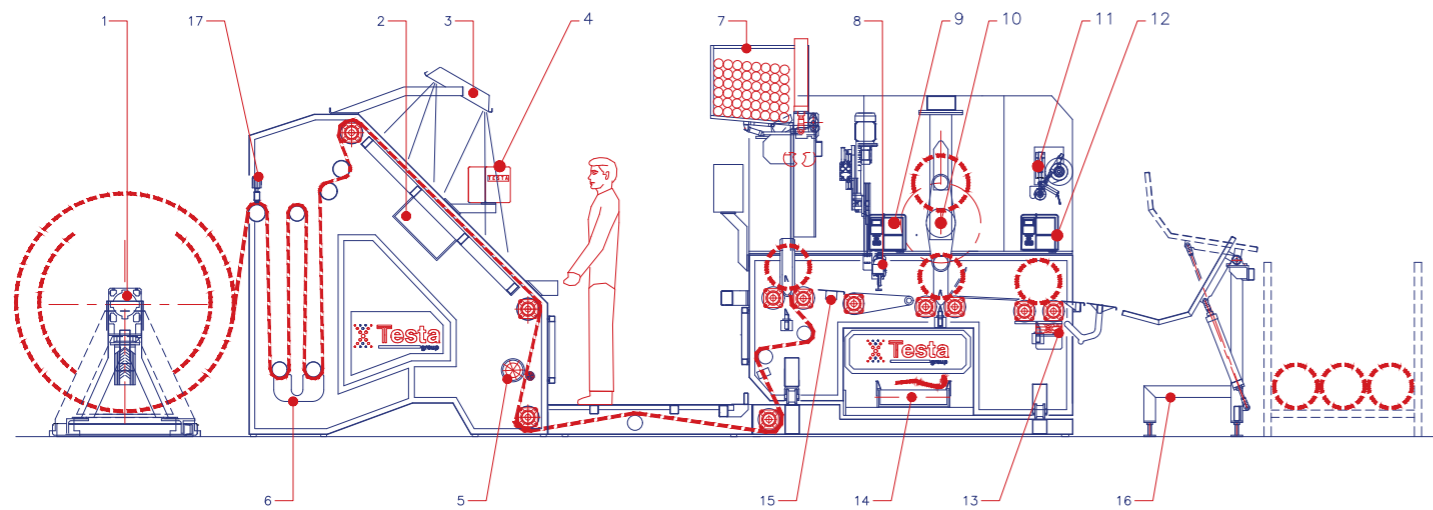

- | | |
|----------------------|-------------------------------------|
| 1. input by big roll | 10. robot for second choices |
| 2. internal light | 11. radial taping |
| 3. external light | 12. labeller |
| 4. touchscreen panel | 13. weighing device |
| 5. meter counter | 14. conveyor for rejection |
| 6. compensator | 15. automatic cutting-sewing device |
| 7. automatic hopper | 16. tilting device |
| 8. automatic cutting | 17. stop-fabric device |
| 9. samples labeller | |

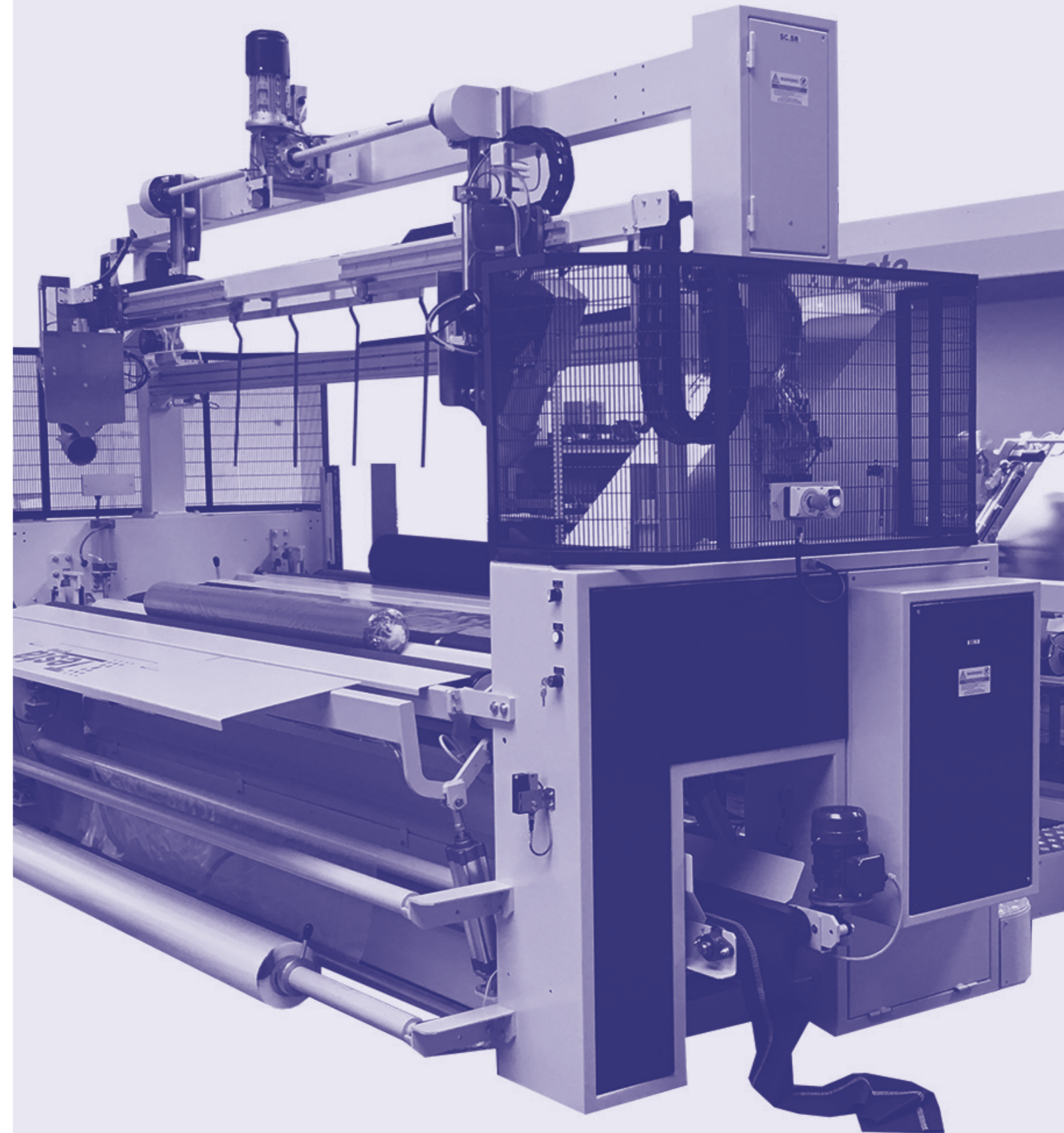

Our certifications
Le nostre certificazioni



Testa Group S.r.l.
Via Crema, 8/C - 24050, Zanica (BG) Italy
+39 035 670444
info@testagroup.eu



[testagroup.eu](https://www.testagroup.eu)