

SANTEX  
RIMAR  
GROUP

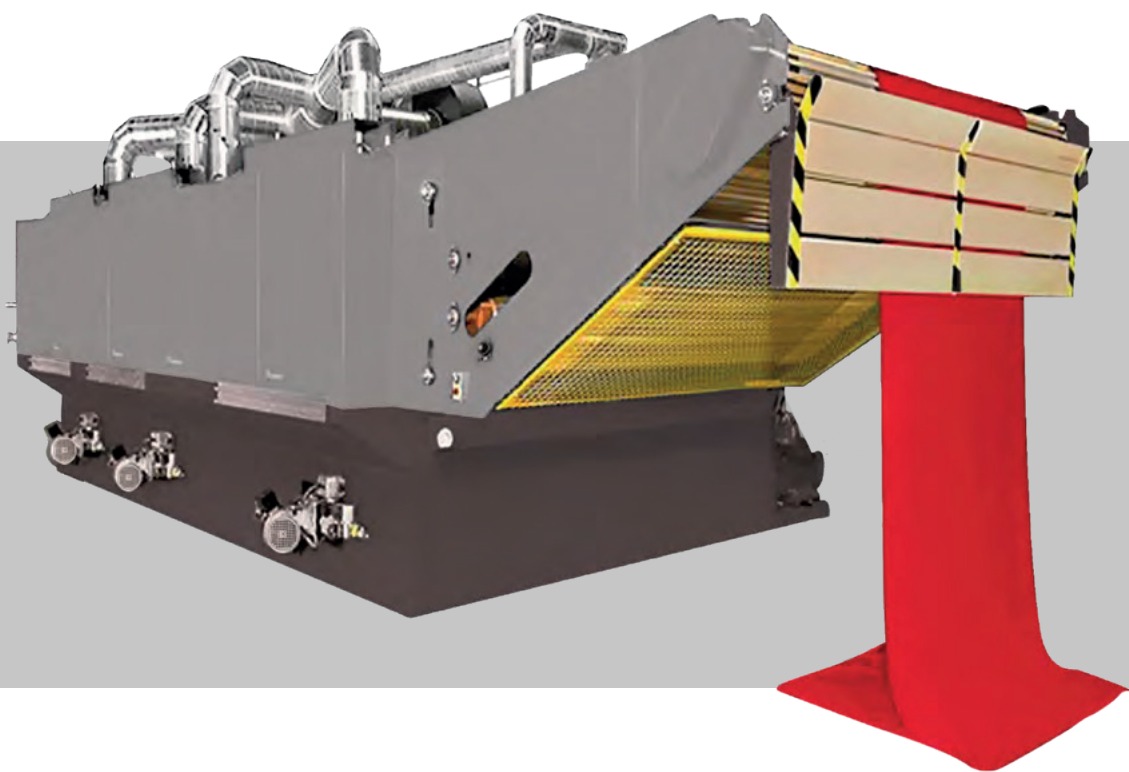

# SANTASHRINK

TENSIONSLESS DRYING,  
SHRINKING AND RELAXING

# SANTASHRINK

## Tensionless shrinking and relax drying of tubular and open width knitted fabrics in a wide variety of versions

The length of the drier or number of chambers is chosen according to the required drying capacity.

The fabric is laid on the transporting belt at the feeding unit, which includes the overfeeding roller and a special apron. The fabric is ideally guided in wave form through the drier.

The nozzle alignment forces the fabric to a fast and intensive drying, which includes tumbling effect.

The moisture control inside chambers is optimized for energy saving reasons.

A steaming and vibration chamber enhances the bulkiness and the shrinking process.

The exit unit is composed of an inclined wooden lathed belt to cool down the fabrics before plaiting.

Every chamber is equipped with manual lint filters, which can be easily cleaned during operation. Optionally, an automatic lint filter system can be built in instead.

The process control is easily monitored via Santavision, HMI equipped with touch screen panel.

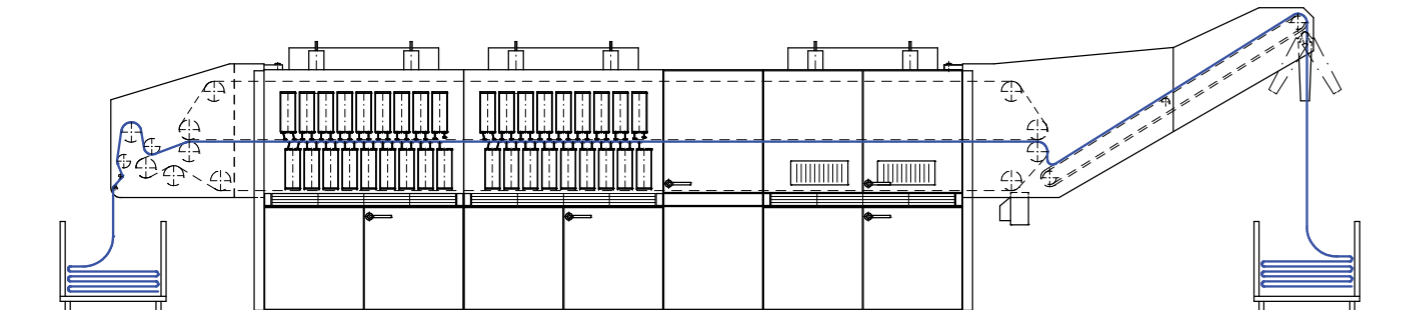

## Advantages

- Easy operation
- High water evaporation power
- High productivity
- Very low energy consumption
- Extremely uniform temperature distribution in the drying zone
- Highly effective thermal insulation
- Finely adjustable drive system for individual functional ranges, independently controlled
- Adjustable distance between upper and lower nozzles
- Intensive steaming and vibration chamber to achieve an outstanding residual shrinkage value.

## TECHNICAL DATA

Working width	60-420 cm in steps of 20 cm, others on request
Total width	Working width plus 200cm
Length of drying chamber	2 m
Total machine length	Number of chambers plus approx. 5.5 m includ. the vibration section
Evaporation capacity	200 kg per drying chamber
Fabric overfeed	0-50% infinitely variable
Fabric guidance	One ore more parallel strands according to requirement
Heating system	Steam, natural or liquid gas or thermal oil

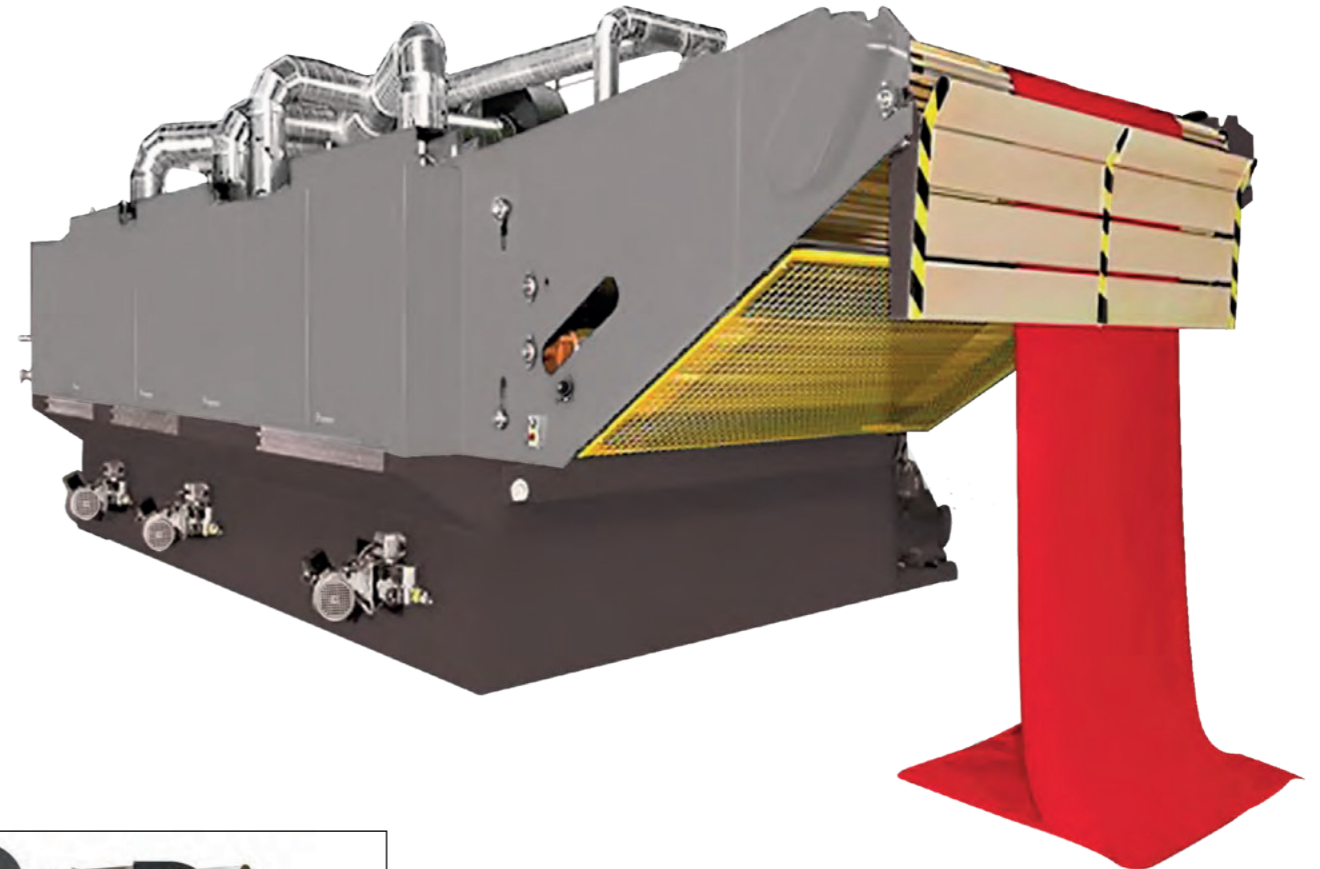

## SANTASHRINK

For the shrinkage, relaxation and tensionless drying of tubular and open-width knitted fabrics. The fabric guidance, whether single, double or multiple strand is effected at one treatment level.



Prior to the drying chamber, the fabric passes through a steam and vibration section, which helps to enhance the fabric volume and soft handle.



Nozzles with large volumes of air enable the water to be heated very quickly to the evaporation point.



## SANTASHRINK Progress

The standard version of the SANTASHRINK series serves as the basis for the SANTASHRINK PROGRESS machine-which is usually equipped with 3 or more drying chambers.

An equalizing frame, which features a needle chain, is the most important part of the extended inlet. The total length of 5.345 m includes a horizontal swivelling section of 4.50 m, which permits gentle opening and overstretching of the fabric. The inlet can be of very simple design with a centering device and a feeding support. In general, however a dewatering-padder is provided and in most cases, also an impregnating padder.

SANTEX  
RIMAR  
GROUP

SPEROTTO RIMAR Srl

Località Colombara 50 - 36070 Trissino (VI) - ITALY  
Tel. +39.0445.1761444 - Fax +39.0445.1761445  
sperottorimar@santexrimar.com - www.santexrimar.com

SANTEX RIMAR GROUP Worldwide

- Italy
- Switzerland
- China
- India

CAVITEC

ISOTEX

SANTEX



SMIT

SOLWA

SperottoRimar